

**ASSESSMENT EVALUATION REPORT**

**FOR**

**RALPH NORDLING, BONNIE NORDLING, & AL RUDIS**

**50 MILE CREEK AREA  
115N-5 & 115N-6**

**PLACER CLAIMS:**

**BON 1-52 (P44373-P44424), holder Bonnie Nordling  
BON 53 (P44497), holder Albert Rudis  
BON 54 (P44498), holder Ralph Nordling  
BER 1-30 (P44335-P44364), holder Ralph Nordling**

120139

120100

**Assessment Period: SEPT. 1999 - SEPT. 2000**

**Albert W. Rudis**

**February 18, 2001**

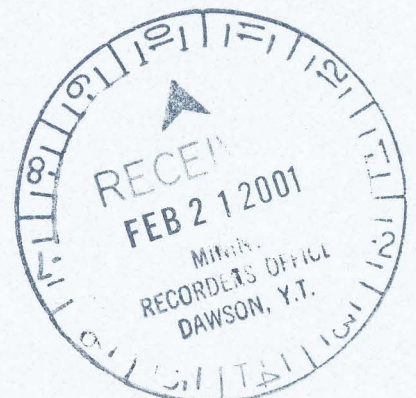

## TABLE OF CONTENTS

### 1. REPORT:

- a) Claim Information: pg. 5
- b) Location Map:
- c) Claim Map:
- d) Survey Grid Locations:
- e) Access:
- f) Magnetic Survey Grids:
  - 1. Cheryl Creek (Ber 1-30):
  - 2. Cheryl Creek Mouth (Sestack Pit):
  - 3. 50 Mile Terrace: pg. 6

### 2. SUMMARY:

- a) Cheryl Creek (Ber 1-30):
- b) Cheryl Creek Mouth (Sestack Pit):
- c) 50 Mile Terrace:
- d) Placer Gold Source Location: pg. 7

### 3. GEOLOGY AND PREVIOUS RELEVANT INVESTIGATION:

- a) General Geology: pg. 8
- b) Major Rock Units: pg. 9
- c) Other Rock Units:
- c) Local Structure:
- d) Previous Work and Significance:

### 4. CURRENT WORK PERFORMED:

pg. 13

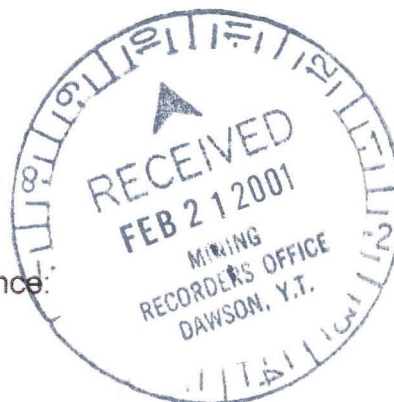

This report has been examined by  
the Geological Evaluation Unit under  
Section 4 of the Miner's Act  
and is recommended as allowable  
representative work in the amount  
of \$ 22,417.54.

*for* *W. LeBarge*

Chief Geologist, Exploration and  
Geological Services Division, Northern  
Affairs Program for Commissioner of  
Yukon Territory.



- a) Two Mile Total Magnetic Field Survey:
- b) Short Total Magnetic Field Survey:
- c) Gold Source Concentration:

#### 5. WORK METHOD :

- a) Total Magnetic Field Surveys:
- b) Gold Source Sampling: pg. 14

#### 6. RESULTS:

- a) Total Magnetic Field Survey Along Cheryl Creek:
- b) Short Total Magnetic Field Survey: pg. 15
- c) Third Magnetic Field Survey:
- d) Search for Placer Gold Source: pg. 16

#### 7. CONCLUSIONS : pg. 17

- a) Principal Cheryl Creek Survey:
- b) Short Survey at Mouth of Cheryl Creek: pg. 18
- c) Third Total Magnetic Field Survey:
- d) Search for Placer Gold Source:
- e) High Economic Potential: pg. 19
- f) Cheryl Creek Test Needs:
- g) Upper Cheryl Creek Anomaly:

#### 8. RECOMMENDATIONS:

- a) Cheryl Creek Potential:
- b) Upper Cheryl Creek Survey:
- c) Cheryl Creek Mouth:
- d) 50 Mile Terrace Concentration Channel: pg. 20
- e) Extended 50 Mile Terrace Survey:
- f) Ral Placer Claims Survey:
- g) Placer Gold Source:

9. ATTACHMENTS AND APPENDICES:

- a) Attachment 1: *Total Magnetic Field Survey of the Cheryl Creek Property, Fifty Mile River Area, Yukon Territory, A Report for Al Rudis by Amerok Geosciences, Ltd., dated October 24, 2000.*
- b) Attachment 2: Cheryl Creek Mouth (Sestack Pit) Profile.
- c) Attachment 3: 50 Mile Terrace Profile.
- d) Attachment 4: Grid Locations for Sestack Pit and 50 Mile Terrace.
- e) Attachment 5: Manually Annotated copy of Total Magnetic Field Survey Stacked Profile (fig. 4) from Attachment 1, showing current stream, side hill, and sample locations.
- f) Appendix 1: Location Map.
- g) Appendix 2: Claim Map.
- h) Appendix 3: Statement of Qualifications.
- i) Appendix 4: Certification of Costs.

**1. REPORT:** This assessment evaluation report covers the grouped placer claims listed below. It was accomplished in the end of August 2000, for the Assessment period from between August/September 1999 and August/September 2000.

a) Claim Information: Claims included for this assessment work include:

BON 1-52 (P44373-P44424), holder Bonnie Nordling  
BON 53 (P44497), holder Albert Rudis  
BON 54 (P44498), holder Ralph Nordling  
BER 1-30 (P44335-P44364), holder Ralph Nordling

b) Location Map: The general location of the 50 Mile Creek area is given in Appendix 1.

c) Claim Map: Claim Maps are given in Appendix 2.

d) Survey Grid Locations: Survey Grid locations are given at Appendix 3.

e) Access:

Primary access to the 50 Mile Creek and Cheryl Creek Claim Areas is by helicopter. Limited access is by truck up to the Matson Creek road, and then to the old Mar West mining access road that runs along the ridge line leading to Hart Mountain. Access from the end of this road is within about 1 mile from the top of the target area. From there a difficult transit can be made by foot. Some assist may be possible by 4 wheeler.

f) Magnetic Survey Grids:

1. *Cheryl Creek (BER 1-30):* The primary survey grid was laid out over two miles of the length of Cheryl Creek. Detailed grid description and mapping are found at Attachment 1: *Total Magnetic Field Survey of the Cheryl Creek Property, Fifty Mile River Area, Yukon Territory, A Report for Al Rudis by Amerok Geosciences, Ltd.*
2. *Cheryl Creek Mouth (Sestack Pit):* This short grid at the mouth of Cheryl Creek was laid out to intersect an old timer pit with high grade showing. It consists of three parallel lines 7.5m apart and 17.5m long. Stations were at 2.5m. The Total Magnetic Field Stacked Profile Figure (Attachment 2) was computer generated by Aurora Geosciences, and later manually

interpreted. Scale, orientation and line location had to be manually corrected. Grid location is shown at Attachment 4.

3. *50 Mile Terrace*: This grid is on the western end of the Bon 54 claim on the 50 Mile Terrace just below the Cheryl Creek mouth. The baseline runs 150m with stations 5m apart and lines about 300m long. The Total Magnetic Field Stacked Profile Figure (Attachment 3) was computer generated by Aurora Geosciences, and later manually interpreted. Grid location is shown at Attachment 4.

## 2. SUMMARY:

- a) *Cheryl Creek (BER 1-30)*: *The Principal Total Magnetic Field Survey* was run on the first two miles of Cheryl Creek. Anomalies, probably from placer magnetite, are present the full length of the survey. Earlier sampling on the first mile of the creek indicate values of \$6 to \$9 dollars per yard. This sampling showed that higher gold values are related to higher amounts of magnetite. The extent of the outlined magnetic concentrations outlined, the values of placer gold and a shallow depth to pay, give Cheryl Creek a high economic potential. Trenching on upper Cheryl Creek and trenching and bulk testing on lower and middle Cheryl Creek are needed to confirm this potential. Magnetic anomalies extending to the top the survey grid indicate that they probably extend to the top portion of Cheryl Creek.
- b) *Cheryl Creek Mouth (Sestack Pit)*: A Short Total Magnetic Field Survey was run at the Mouth of Cheryl Creek. The Survey indicates a possible magnetite enrichment over the width of the mouth surveyed (17.5m). A pit sampled in the general enrichment area runs over \$25 per yard. Placer at the mouth of Cheryl Creek could be an overall high grade. While tonnage is low, it would be a good start up target under a Class 4 stream classification. Intersection of water table at 4.5' down prevented getting to bedrock. Pit sampling should be carried out to get to bedrock and to get estimate of overall value and yardage at the Cheryl Creek mouth.
- c) *50 Mile Terrace*: A Third Total Magnetic Field Survey was run on the western end of the Bon 54 claim on the 50 Mile Terrace just below the Cheryl Creek mouth. It shows a possible magnetite enrichment channel that builds in intensity as it goes East. It runs the length of the 150m baseline with a width that increases from 100m to 175m as it moves downstream. This is significant because it appears to correlate with a very high anomaly possible magnetite enrichment channel found in an earlier magnetic survey. That anomaly runs 100m long, 60m

wide, and is open on both ends. A minimum of 150m separate the two anomalies, indicated a probable continuity of magnetite enrichment channel 350m long and open to the East. The magnitude (over 300 gamma) of the earlier survey indicates a very high enrichment of magnetite. Magnetite enrichment is important because in all the sampling done so far in the area, the higher the concentration magnetite the higher the gold values. This projected anomaly should have a high priority for testing by shafting, drilling or trenching.

- d) *Placer Gold Source Location:* Outcrops exposed at the ends of Survey lines were checked for their potential as a placer gold source. Placer gold on Cheryl Creek is coarse and has enclosed brittle crystals of cuprite. This indicates a source of placer gold within the claim block. Location of the source could pinpoint concentration zones. Sampling shows that Cheryl Creek is cut by several zones of heretofore unrecognized ultramafic. No direct evidence of a gold source was found. The principal magnetic survey on Cheryl creek did disclose two major hardrock magnetic anomalies within the grid. The area around these should be checked as possible enrichment zones in the placer.

### 3. GEOLOGY AND PREVIOUS WORK:

- a) General Geology: The local geology of the area is described in DIAND Open File 1996-1G, specifically in its coverage of 115N/15,16. It states:

“Northern Stewart River map area southwest of the Tintina Fault Zone is underlain by two distinct lithotectonic assemblages: 1) medium to high grade, polydeformed metasedimentary and met-igneous rocks of the Yukon-Tanana Terrane, and 2) weakly deformed and metamorphosed rocks to the Slide Mountain Terrane. These two assemblages are both mainly Paleozoic in age in the study area, and were juxtaposed by regional scale thrust faults in Early Mesozoic time, during a period of terrane accretion that affected much of the northern Cordillera. A variety of younger (post-accretion) volcanic, plutonic and sedimentary rocks are also present in the study area.”<sup>1</sup>

The claim area falls within the Yukon-Tanana Terrane as described in this Open File.

- b) Major Rock Units:

- 1Kva: andesite flows and breccias. (late Cretaceous)
-

- DMS: medium to coarse grained mica schist. Commonly garnetiferous amphibolite, minor quartzite. (late Devonian)
- 1Kgdr: massive hornblende-biotite granodiorite. (late Cretaceous)
- 1Kst: sandstone, pebble conglomerate, minor shale, commonly coal-bearing. (late Cretaceous)
- DMgg: moderately to strongly foliated K-feldspar augen-bearing quartz monzonitic to granitic gneiss (S. Fiftymile Batholith). (early Mississippian)
- EJQM: massive to weakly foliated biotite and biotite-muscovite quartz monzonite and granite; includes abundant pegmatite and aplite phases. (early Jurassic)
- DMC: marble. (late Devonian to early Mississippian)
- 1Kgdr: massive hornblende-biotite granodiorite. (late Cretaceous)
- Psqm: rusty weathering quartz muscovite schist. (late Permian)
- Dmgdg: massive to strongly foliated dioritic to granodioritic gneiss (N. Fiftymile Batholith) (early Mississippian)

c) Other Rock Units:

1. Amerok's Total Magnetic Field Survey Report states that Cheryl Creek is underlain by two rock units. It further states: "To the North of L1190N (about the top of the Ber 12 claim) the property is underlain by metamorphic mafic rocks including amphibolite and ultramafic rocks belonging to the Nising, Nasina, and Slide Mountain assemblages. These rocks appear to strike east-west based on their aeromagnetic signature. South of L1190N, the property is underlain by orthogneiss of the Fifty Mile Batholith. The Report also observes "that the intrusive rocks have a very subdued aeromagnetic signature. Residual magnetite in placer deposits on Cheryl Creek is likely derived from the northern rock unit."
2. Outcrops exposed at the ends of Survey lines show that Cheryl Creek is cut by several zones of ultramafic well below L1190N. Ultramafic has been found at L280S, L120S, L00, L40N, and L720N. Those checked, however, did not appear to be magnetic. A hand pit sample (F3-7) taken in 1998 also exposed a seam of decomposed ultramafic at L1040N. It showed 46ppb Au along with minor W and Hg.
3. Significant to large magnetic hardrock-type anomalies show up on the Report map at L400S - L560S, and L760 - L800N.

d) Local Structure:

1. The area is structurally complex and has a scarcity of exposures. A regional scale thrust fault dominates the 50 Mile Creek along its left limit. The valley of the 60 Mile River in the central and western part of the Sixtymile District follows a northeast-trending graben structure that has downdropped Cretaceous volcanic and sedimentary rocks against metamorphic rocks of the Nasina and Klondike Schist. Cretaceous strata are cut by steeply-dipping normal faults. All of the smaller bodies of greenstone and/or ultramafic rocks in the area are thought to mark thrust faults.
2. There is a probable major fault running east - west at about L1190N. Structure taken at L1360N had a strike of 069° and dip of 30° east. It is notable that the various ultramafic zones crossing Cheryl Creek are probably all related to thrust faults.

e) Previous Work and Significance: There are no MINFILES in the immediate vicinity of Cheryl Creek. Previous work reported in the general area is as follows:

1. *MINFILE #115N 039:* North-northeast striking, mesothermal (?) quartz-carbonate veins with major Ag, Pb and minor Au, Zn. 63-55-29N 140-48-52W
2. *MINFILE #115N 040:* Lenses of galena and arsenopyrite with minor sphalerite, tetrahedrite and boulangerite in northeast-striking quartz veins. Major Ag, Pb and minor Au, Zn. 63-54-50N 140-47-46W
3. *MINFILE #115N 042:* An epidote-magnetite-diopside skarn containing minor chalcopyrite and pyrrhotite developed at the contact between a marble layer and the intrusion (Dms and 1Kgdr). Major Cu, Ag, Pb, Au. 63-54-58N 140-34-35W
4. *MINFILE #115N 043:* 300 m long skarn with traces of malachite and old workings. 63-53-26N 140-37-40W
5. *MINFILE #115N 044:* Late Cretaceous quartz pebble conglomerate (unit 1Kst), with one specimen containing a small rounded flake of gold. The conglomerate has a thickness of 15-30 m and outcrops over approximately 0.8 km. It is capped by, and may extend under, andesitic volcanic rocks (unit 1Kva). No mineralization was found in 1973 by Silver Standard. Paleoplacer with Au as the major commodity. 63-53-18N 140-25-10W
6. *MINFILE #115N 119:* Another outcropping of unit 1Kst defined in MINFILE #115 044. 63-55-10N 140-25-32W

7. MINFILE #115N 123: A thrust -fault-bounded lens of serpentinite occurs along the fault to the east of the occurrence. A vuggy quartz carbonate vein with silver and minor gold, copper and no visible sulphides, outcrops on the hanging wall of the fault. 63-58-31N 140-53-15W
8. MINFILE #115O 158: Traces of disseminated galena within a very rusty weathering band of pyritic muscovite-quartz schist (Psqm) of Klondike Schist assemblage. 63-56-58N 140-42-48W
9. 1960's And 1970's: Early prospecting of the Creek and its pups was done in the 1960's and 1970's by long time Dawson City residents Joe Sestack, Jimmy Lynch and Jim Archibald. Ralph Nordling, one of the current claim holders, assisted Joe during several trips to the area. Aside from his early personal experience, Mr. Nordling has been told the results of these early efforts by each of the prospectors. They reported that the Creek and several of its pups carry gold, but other more accessible areas were of more interest to them at the time. Mr. Archibald and Mr. Sestack both thought the area had high potential for mining. With the exception of some limited backhoe work by Jimmy Lynch, all work was done by hand methods. One shallow hand pit at the confluence of Cheryl Creek, was reported as being relatively high grade.
10. 1989 And 1990: The area was subsequently evaluated by Lorne Mollot under four leases numbered 7563 through 7566. Two Magnetometer Geophysical Reports numbers 120115 and 120116 were filed in 1989, and an Exploratory Auger Drilling report number 120131 was filed in 1990.
11. Magnetic Survey #120116: Magnetic survey 120116 ran lines on the 50 Mile high terrace near the confluence of the Fifty Mile and the pup currently covered by the Ral placer claims. Results included "the possible presence of two separate, parallel gravel strata stranded after successive regional uplifting and stream downcutting". Trenching across this grid was recommended.
12. Magnetic Survey #120115: Magnetic survey 120115 ran lines on the 50 Mile high terrace below the confluence of Cheryl Creek. It concluded that the magnetic response that was found was probably controlled by a local rock unit. It states, however, that there is a possibility that the anomaly indicates the presence of placer material with an unusually large, linear deposit of magnetite in the gravel. Results of our work in 1997-1999 indicates that the source of the anomaly is probably an

auriferous placer magnetite concentration enriched in part by the upstream pup. In 2000, a Total Field Magnetic Survey (reported herein) was run on the southern end of the Bon 54 claim on the 50 Mile Terrace just below the Cheryl Creek mouth. It shows a possible magnetite enrichment channel that builds in intensity as it goes East. It appears to correlate with the anomaly of Survey #120115. This indicates a probable continuity of a magnetite enrichment channel below Cheryl Creek that is at least 350m long, 60m to 175m wide and open to the East.

13. Auger Drilling #120131: Auger Drilling 120131 involved two lines and a total of twenty drill holes. One line was approximately three miles above the current Cher 24 placer claim. The other was in the vicinity of the Cher 1 placer claim. Stated results included "a lack of any appreciable heavy mineral concentrate in the drill samples and a complete lack of gold". It was concluded that this and the general morphology of the valley suggests that the Fifty Mile Creek drainage is of recent origin, probably dating back to the last regional uplift. It states: "the valley has little potential as a placer gold host, and it was therefore recommended that the leases be abandoned". Our work and analysis to date completely refutes this conclusion and the recommendation of Drill Report 120131. Notable drilling deficiencies in #120131 are:
  - a. Magnetic Survey Recommendations Avoided: All drill holes were placed within the 50 mile stream bed and lower bench. No holes were placed in the upper bench, nor were there any placed where recommended by magnetometer survey. The stated reason for avoiding magnetometer survey areas was that these areas were too difficult to get to.
  - b. Upstream Drill Line Has Limited Application: The upstream line was drilled into frozen ground, but did only zero, .5 and 1 foot penetrations into bedrock. Results here may be accurate in the Creek bed gravel as far as it was drilled, but would not apply in the adjacent high bench. Nor would they apply where we have outlined enrichment from pups located several miles downstream. Further, the line's shallow bedrock penetration does not allow for the excellent environment for deep deposit which the high angled, riffle-like blocky bedrock presents even in the local scouring environment that likely prevailed. As an example, current successful mining on Clear Creek, but with a similar bedrock type and

disposition, penetrates as much as 4 feet into bedrock before any gold is reached.

- c. Downstream Drill Line Conditions: The downstream line was drilled entirely into thawed ground, and into what we determined is a well washed, well sorted and virtually clay free gravel. Large boulders that would impede drilling show above the contact exposed at the top of the nearby 35 foot shear rise from the low bench to the base of the high bench. This indicates that boulders can also be expected on the low bench contact, and they are in fact found where bedrock is exposed on the Creek bottom.
- d. Downstream Line Conditions Impacted Results: It is particularly significant that all the holes in the downstream line were drilled in unfrozen gravel and in water. Auger drilling in unfrozen placer gravel without using casing is not recommended procedure, and has been proven to give unreliable results. In this line, accuracy is further impeded because the holes were all in water, the gravel was well washed with little to no clay to bind gold particles, and large cobbles and boulders were present in the column. The natural vibration of the auger; jolts with contact with larger boulders near the expected pay zone; the water medium; and the well-washed, non-binding gravel would have made a natural slide for gold on the auger flights. Under these conditions, gold and black sands encountered in the gravel or bedrock could not be expected to rise with the sample.
- e. Downstream Drill Line Conflicts With Our Field Data: In the one existing hand pit that we could observe and pan in the low bench below the drill point on the stream, an unfrozen water table was intersected at 4.5 feet below the surface. Further, the gravel was well washed, and, even while bedrock was not visible or reachable, it contained high levels of magnetite in association with gold. This pit runs over \$25 per yard in samples taken above bedrock. The gold is associated with well washed gravel and abundant magnetite. 40 Cat pits and long tom sampling conducted in 1999 confirms the widespread presence of gold and black sands.

14. *Glaciation, Gravel and Gold in the Fifty Mile Creek Area, West Central Yukon, Grant W. Lowey, Yukon Geology Program, Nov 1999:*

Dr. Lowey confirmed that placer gold occurs in lower-level terraces located along Fifty Mile Creek and in lower-level terraces located along several tributaries to Fifty Mile Creek, and there is potential for placer gold in upper-level terraces located along Fifty Mile Creek.” Dr Lowey’s pan sample taken over one foot above bedrock at a placer exploration test pit on Cheryl Creek showed a gold content of 0.024oz per cubic yard . The report also describes the gravel column and heavy mineral constituents from selected test pits.

#### 4. CURRENT WORK PERFORMED:

- a) *A Two Mile Total Magnetic Field Survey* was conducted. A description and results on the principal survey are shown in *Total Magnetic Field Survey of the Cheryl Creek Property, Fifty Mile River Area, Yukon Territory, A Report for Al Rudis by Amerok Geosciences, Ltd.*, dated October 24, 2000. It is included as Attachment 1.
- b) *A Short Total Magnetic Field Survey* was run at the Mouth of Cheryl Creek. It consists of three parallel lines 7.5m apart and 17.5m long. Stations were at 2.5m. It crossed a high grade hand pit originally dug by Sestack in the 1960's. The Total Magnetic Field Stacked Profile Figure (Attachment 2) was computer generated by Aurora Geosciences, and later manually interpreted. Grid orientation, scale and line location had to be manually corrected. Grid location is shown at Attachment 4.
- c) *A Third Total Magnetic Field Survey* was conducted on the southern end of the Bon 54 claim on the 50 Mile Terrace just below the Cheryl Creek mouth. The baseline runs 150m with station lines 5m apart and about 300m long. The Total Magnetic Field Stacked Profile Figure (Attachment 3) was computer generated by Aurora Geosciences, and later manually interpreted. Grid location is shown at Attachment 4.
- d) *Gold Source Concentration:* Samples to help locate the placer gold source and possible concentrations were taken in proximity to the ends of the Survey grid lines. Eighteen samples were taken. One pan sample from a shallow pit was taken.

#### 5. WORK METHOD :

- a) *Total Magnetic Field Surveys:* Surveys were conducted in the period August 19 through 25, 2000. A pair of proton precession magnetometers were utilized using one instrument as a base station and the second as the field unit. All field data was corrected for temporal geomagnetic variation using the bases station. Al Rudis and

Ralph Nordling provided overall direction and supervision. Shawn Ryan operated the magnetometers. Two technicians assisted in line cutting, grid layout, and flagging. The main field survey line covered Cheryl Creek with 10.5 line km on 84 lines, surveying at a 5m station spacing over a flagged grid centered on the creek center line. The short grid at the mouth of Cheryl Creek consists of three parallel lines 7.5m apart and 17.5m long. Flagged stations were at 2.5m. The flagged grid on the Southern end of the Bon 54 claim on the 50 Mile Terrace just below the Cheryl Creek mouth has a baseline that runs 150m with stations 5m apart and lines about 300m long. Method and personnel are also discussed in the Amerok report (Attachment 1).

- b) *Gold Source Sampling* locations were in proximity to outcrop and slide materials adjacent to line cuts. One small pit was dug, sampled and panned. Persons sampling were Al Rudis, Ralph Nordling, and Shawn Ryan.

## 6. RESULTS:

### a) *The Total Magnetic Field Survey:*

1. The Total Field Magnetic Survey along Cheryl Creek shows a semi-continuous magnetic anomaly that probably defines an old stream channel of high magnetic concentration. This probable stream channel extends the full two mile length of the survey. This is quite significant as earlier hand and cat pit samples consistently showed values of \$6 to \$9 per yard at pay.
2. It should be noted that The Amerok analysis defines a relatively insensitive placer channel magnetic model that utilizes over 110 gamma. Selection of a larger scale for the stacked profile and a more sensitive model would highlight numerous 40 gamma anomalies and define several other potential magnetite channels.
3. A 120 to 160m long, high value anomaly located about lines 400S to 520S is not mentioned in Amerok analysis. The very high range of this anomaly (up to 500 gamma) is extraordinary for a placer source, and indicates a potential hard rock target. But the magnetometer operator particularly noted that the signature of this anomaly (as its readings were taken) were consistent with the placer highs identified elsewhere on the creek. The high reading range is also consistent with the previously discussed 300 gamma anomaly found in Report #120115. Further, the trend of the anomaly is parallel to the stream channel and cuts across local hardrock structure.

4. This very high Cheryl Creek anomaly should be considered a possible magnetically enriched stream channel. The area of the anomaly should receive high priority for sampling to determine if it is of placer origin and to test for possible high grade placer gold.
5. Attachment 5 is a manually annotated copy of Total Magnetic Field Survey Stacked Profile (fig. 4) from Attachment 1 (*Total Magnetic Field Survey of the Cheryl Creek Property, Fifty Mile River Area, Yukon Territory, A Report for Al Rudis by Amerok Geosciences, Ltd.*). It shows the current stream channel, and side hill location.
  - a) *The Short Total Magnetic Field Survey* run at the Mouth of Cheryl Creek crossed a hand pit originally dug by Sestack in the 1960's. The pit, sampled by long tom, ran over \$25 per yard at some unknown distance above bedrock. Attachment 2, Total Magnetic Field Stacked Profile Figure, shows a probable magnetite enrichment over the width of the mouth surveyed (17.5m). The Sestack Pit is in the general enrichment area, and outside of the possible western magnetic channel. This indicates that the overall mouth of Cheryl Creek could be a high grade. While yardage is low, it would be a good start up target under a Class 4 stream classification. Class 3 stream classification would probably preclude its mining.
  - b) *The Third Total Magnetic Field Survey:*
    1. This survey shows a possible magnetite enrichment channel that builds in intensity as it goes East. It runs the length of its 150m baseline with a width that starts at 100m and increases downstream to 175m at the last line. This is quite significant because it appears to correlate with a very high value (over 300 gamma), possible magnetite enrichment channel found in a magnetic survey done by Yukon Engineering Services in 1989 (above listed Report #120115). This anomaly runs 100m long, 60m wide, and is open on both ends. Its magnitude indicates a very high enrichment of magnetite. Magnetite enrichment is important in the area because in all the sampling done so far, the higher the concentration of magnetite the higher the gold values. Also, virtually all samples that contained magnetite, contained some gold.
    2. The #120115 survey is directly East of the current one and is located on placer claim Bon 52. About 150m separate the two anomalies, indicating a possible continuity of a magnetite

enrichment channel 350m long, 60m to 175m wide, and open to the East and West.

3. Two additional previous magnetic survey reports should be considered in evaluating the possible length of the indicated magnetic stream channel. Magnetic Survey Report #120016 (discussed above as previous work) crosses the confluence the pup of the Ral placer claims 2.25 miles up from the defined beginning of the current survey anomaly. It was placed in this area because it covers virtually flat bench type deposits that extend approximately 200m across the valley. The same conditions occur down to the current survey, and indeed down another five miles below the current survey. The #120116 survey has a baseline of 750m extending both downstream and upstream of the Ral pup confluence. It showed two parallel separate strata of magnetitic gravel, "stranded after successive regional uplifting and stream downcutting." Similarly, Magnetic Survey Report #120093, done in 1988, showed two potential magnetitic stream channel targets. One was 100m long and large and well defined, the other was 50m long and medium sized and well defined. The #120093 grid line is located about 1.5 miles above Ral pup.
  4. It is possible that the 50 mile Terrace contains a long semi-continuous series of magnetically enriched stranded stream channels that may extend the full four miles between Surveys #120116 and 120093. As the anomaly of the most downstream magnetic survey is very large and open to the West, determining how far it goes and its intensity should be a priority. Determining contained gold values is of course also a high priority.
- c) *Search for Placer Gold Source:* Sampling shows that Cheryl Creek is cut by several zones of heretofore unrecognized ultramafic. No direct evidence of a gold source was found. The principal magnetic survey on Cheryl Creek (Attachment 1) disclosed two significant to large magnetic hardrock-type anomalies shown on the Report map at grid lines L400S - L560S, and L760 - L800N. The anomaly at L400S - L560S should also be considered of possible placer origin. The area around these should be checked as possible enrichment zones in the placer. Two 1/3 pan samples from small 2' deep pit near the base line at L00 showed an estimated \$5 per yard at the depth of sample. Distance to bedrock is unknown. Under 30X, also showed a clear sapphire blue mineral with included gold. Attachment 5 is a manually annotated copy of Total Magnetic Field Survey Stacked Profile (fig. 4) from Attachment 1 (*Total Magnetic Field Survey of the Cheryl Creek Property, Fifty Mile River Area, Yukon Territory, A Report for Al Rudis*

by Amerok Geosciences, Ltd.). It shows sample location. Sample rock types are as follows:

- 1) Shabber-1-Float: Float . Quartz with pyrite, chalcopyrite, and sphalerite mineralization along contact with schist edge.
- 2) Post-2-Ber-18: Float from bank. Ultramafic. Mostly pyroxene and olivine.
- 3) Post-2-Ber-18 River: Float from bank. Felsic quartz, feldspar pegmatitic rock in contact with small lens of pyroxene, serpentinized olivine, phlogopite. Lenses appear injected along fracture with little alteration of host rock. Shows 1624ppm Ba, 98ppmCr, and 511ppmSr.
- 4) 00-W80: Slide rock on bank. 30'X30' exposed. Ultramafic. Possible intrusive. Pyroxene, serpentinized olivine. (1134ppm chrome).
- 5) 1N 110W A: Slide rock on bank. Ultramafic with quartz inserted along fractures. One quartz pod 12"X5". Quartz microstructure.
- 6) 1N 110W: Slide rock on bank. Very dark mafic gneiss.
- 7) 14N 180W: Slide rock on bank. High quartz gneiss or schist with quartz stringers up to 4" thick.
- 8) 14N 180WA: Slide rock on bank. High quartz gneiss or schist with quartz stringers up to 4" thick.
- 9) 18N 140E: Outcrop. High quartz gneiss with 4" thick quartz vein. Nearby olivine/pyroxene float.
- 10) 25N 140E: Slide rock on bank. Light felsic gneiss. 12ppb Au.
- 11) 34N 00: Float from bank. 1 foot X 1 foot not rounded, rough rock of pure milky white limestone. No alteration shown. 9ppbAu.
- 12) 34N 140MO, 34N 140M1A, 34N 140M1B, 34N 140M1C: Outcrop 30'X30'. High quartz banded gneiss with pronounced gossan. Strike 069°, Dip 30° E. 100ppmZn, 29ppmCu, 5ppmMo.
- 13) S3N 120E: Slide Rock from bank. Ultramafic and Quartzite in close proximity. Samples mixed giving light ultramafic signature to ICP. 64ppmZn, 37ppmCu, 8ppmAu.
- 14) S7 EndW 40 B: High quartz schist or gneiss with sparse pyrite.
- 15) S1N-30E, S3N-20E, S17N-20E: Sediment samples.

## 7. CONCLUSIONS:

- a) *Principal Cheryl Creek Survey*: Conclusions and Recommendations presented in the Amerok report on the Cheryl Creek Magnetic Survey are: "The results of the total magnetic field survey conducted on the Cheryl Creek property indicate the location of several anomalies which could be arise form placer magnetite concentrations. These anomalies

should be investigated on the ground and tested by excavation if resources permit. Those anomalies with higher amplitudes and flanking negative anomalies should be investigated first." Also: "Many of these lack flanking troughs suggesting that the deposits are deeper than they are thick." There are also several lesser intensity potential magnetic channels that would show up in a stacked profile sensitive at the 40 gamma range. These should be identified and sampled as resources are available. A possible high grade potential, very large anomaly (over 500 gamma) should be considered of possible placer origin and should receive high priority in testing.

- b) *Short Survey at Mouth of Cheryl Creek:* Attachment 2, Total Magnetic Field Stacked Profile Figure, shows a probable magnetite enrichment over the width of the mouth surveyed (17.5m). The high grade Sestack Pit is in the general enrichment area, and outside of the possible western magnetic channel. This indicates that the overall mouth of Cheryl Creek could be a high grade. While tonnage is low, it would be a good start up target under a Class 4 stream classification. Class 3 stream classification would probably preclude its mining.
- c) *Third Total Magnetic Field Survey:* On the upstream end of Bon 54 there is a possible magnetite enrichment channel that builds in intensity as it goes East. . It runs the length of its 150m baseline with a width that starts at 100m and increases downstream to 175m at the last line. It most likely correlates with a very high anomaly (300 gamma), possible magnetite enrichment channel found in a magnetic survey done by Yukon Engineering Services in 1989 (above listed Report #120115). This anomaly runs 100m long, 60m wide, and is open on both ends. Its magnitude indicates a very high enrichment of magnetite. Magnetite enrichment is important because in all the sampling done so far in the area, the higher the concentration of magnetite the higher the gold values. Survey #120115 was directly East of the current anomaly and on claim Bon 52. A minimum of 150m separate the two anomalies, indicating a probable continuity of a magnetite enrichment channel 350m long and 60m to 175m wide, It is open to the East and to the West. *It is possible* that the 50 mile Terrace encloses a long semi-continuous series of magnetically enriched stranded stream channels that may extend the full four miles between Surveys #120116 and 120093. As the anomaly of the most downstream magnetic survey is very large and open to the West, determining how far it goes and its intensity should be a priority. Determining contained gold values is of course also a high priority.
- d) *Search for Placer Gold Source:* Sampling shows that Cheryl Creek is cut by several zones of heretofore unrecognized ultramafic. No direct evidence of a gold source was found. The principal magnetic survey

on Cheryl Creek (Attachment 1) disclosed two possible significant to large magnetic hardrock-type anomalies shown on the Report map at grid lines L400S - L560S, and L760 - L800N. The area around these should be checked as possible enrichment zones in the placer.

- e) *High Economic Potential:* Earlier sampling on the first mile of Cheryl Creek indicate values of \$6 to \$9 dollars per yard. This sampling showed that higher gold values are related to higher amounts of magnetite. The extent and strength of the outlined magnetic concentrations outlined, the values of placer gold, thin to no muck cover and a shallow depth to pay, give Cheryl Creek a high economic potential. There is high grade potential at the Cheryl Creek mouth, and possibly at a very high (500 gamma) anomaly in the vicinity of L400S - L560S.
- f) *Cheryl Creek Test Needs:* Trenching on upper Cheryl Creek and bulk testing on lower and middle Cheryl Creek are needed to confirm creek's high economic potential. Priority attention should be given to testing in the vicinity of the very high grade potential placer enrichment channel in the area of L400S to L560S.
- g) *Upper Cheryl Creek Anomaly:* Magnetic anomalies extending to the top the survey grid indicate that they probably extend to the top portion of Cheryl Creek.

## 8. RECOMMENDATIONS:

- a) *Cheryl Creek Potential: Confirm the indicated high economic potential of Cheryl Creek. Trenching and shafting on magnetic anomalies defined on upper Cheryl Creek should be carried out. Bulk testing and trenching/shafting on magnetic anomalies defined on the lower and middle Creek should also be carried out. Priority attention should be given to testing in the vicinity of the very high grade potential placer enrichment channel in the area of L400S to L560S.*
- b) *Cheryl Creek Mouth: Confirm the indicated high grade potential at the mouth of Cheryl Creek. Pit sampling should be carried out to get to bedrock and to get estimate of overall value and yardage at the Cheryl Creek mouth.*
- c) *Upper Cheryl Creek Survey: Conduct further Total Magnetic Field Survey on upper Cheryl creek to extend the magnetic anomaly that runs to the top limit of the survey grid.*

- d) 50 Mile Terrace Concentration Channel: Place a high priority on the further definition and evaluation of the Report #120115, probable 350m long, 60m wide magnetic concentration channel on the 50 Mile Terrace below Cheryl Creek. Anomaly magnitude indicates a very high enrichment of magnetite and possibly gold. Testing by shafting, drilling or trenching should be carried out to confirm the presence of the magnetite channel and to define the presence and extent of gold values. A Total Magnetic Field Survey should be run on the open end of the anomaly to determine how far it runs, how wide it becomes and the continuing level of its intensity.
- e) Extended 50 Mile Terrace Survey: As there are indications that the 50 mile Terrace could contain a long semi-continuous series of magnetically enriched stranded stream channels that extends the full four miles between previously conducted Surveys #120116 and 120093, priority should be given to selectively running magnetic surveys along the four miles to determine continuity. The goal would be to see if the probable magnetite enriched channel below Cheryl Creek continuously extends up the 50 Mile above Cheryl Creek. Another goal would be to see if high intensity potential magnetite enrichment channels similar to that below Cheryl Creek, extend below other tributaries of the 50 Mile.
- f) Ral Placer Claim Survey: Carry out a Total Magnetic Field Survey on the pup covered by the Ral placer claims. Earlier trenching and exploration of the Ral claims pup shows values and deposition environment similar to Cheryl Creek. Confirmation of probable placer magnetite anomalies on this pup is probable and would significantly add to the possible indicated placer gold reserves of the property.
- g) Placer Gold Source: Continue efforts to locate placer gold source and potentially high associated placer gold concentrations on Cheryl Creek. Focus on the two probable major hardrock magnetic anomalies within the grid. The area around these should be checked as possible enrichment zones in the placer.

50 Mile Project  
Location

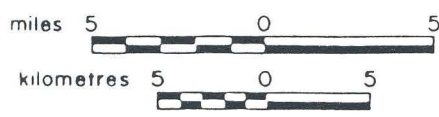
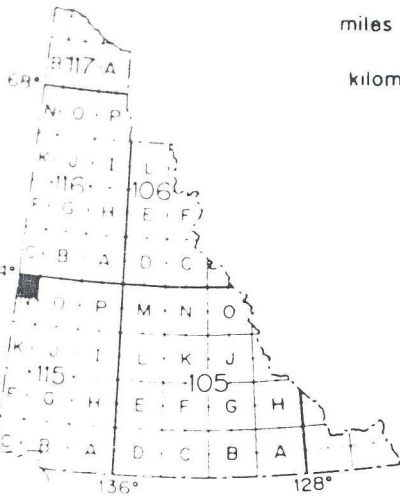
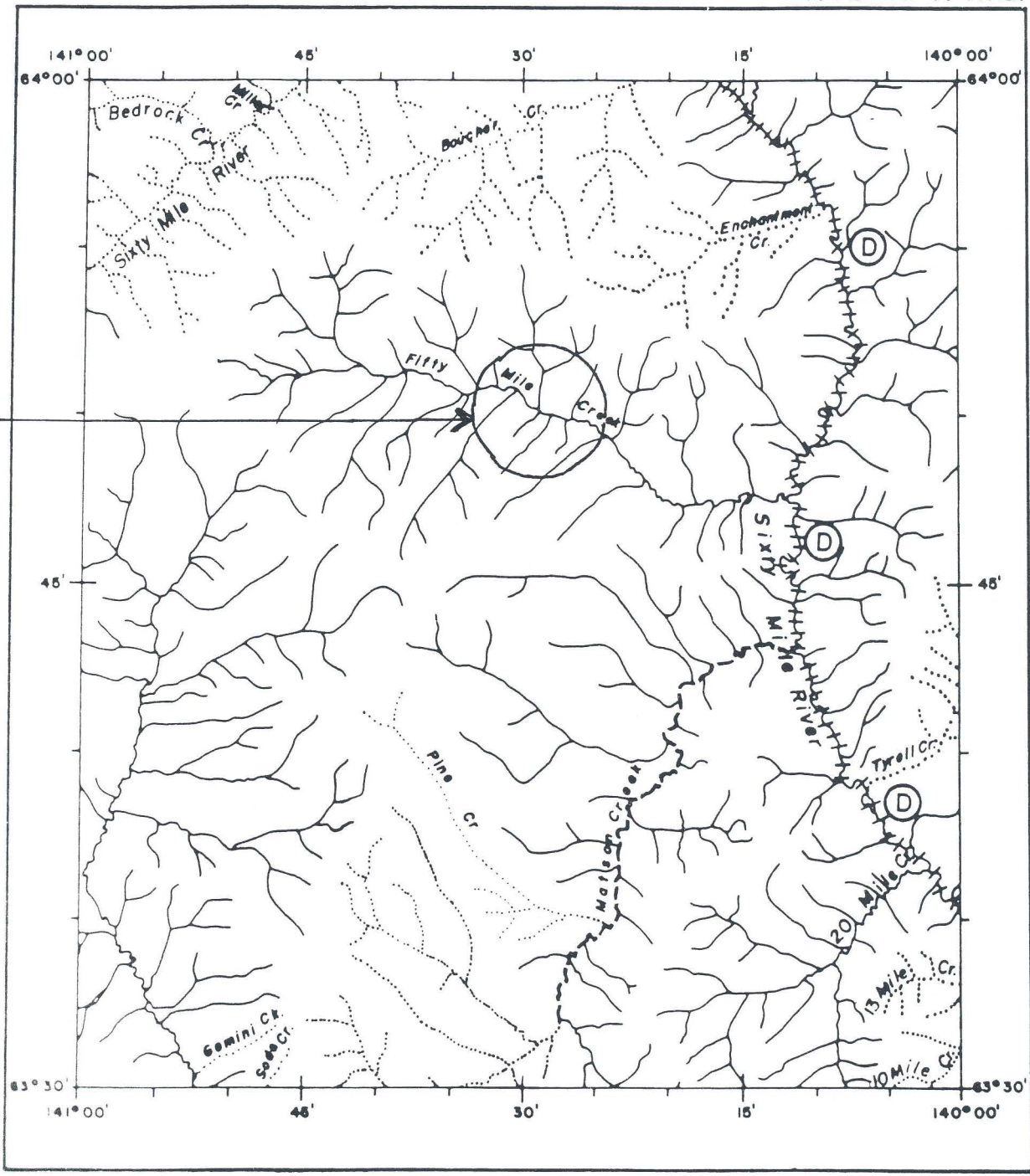

- Type I
- Type II
- Type III
- Type IV
- Type V

# YUKON PLACER AUTHORIZATION

APPENDIX 2A  
CLAIM MAP

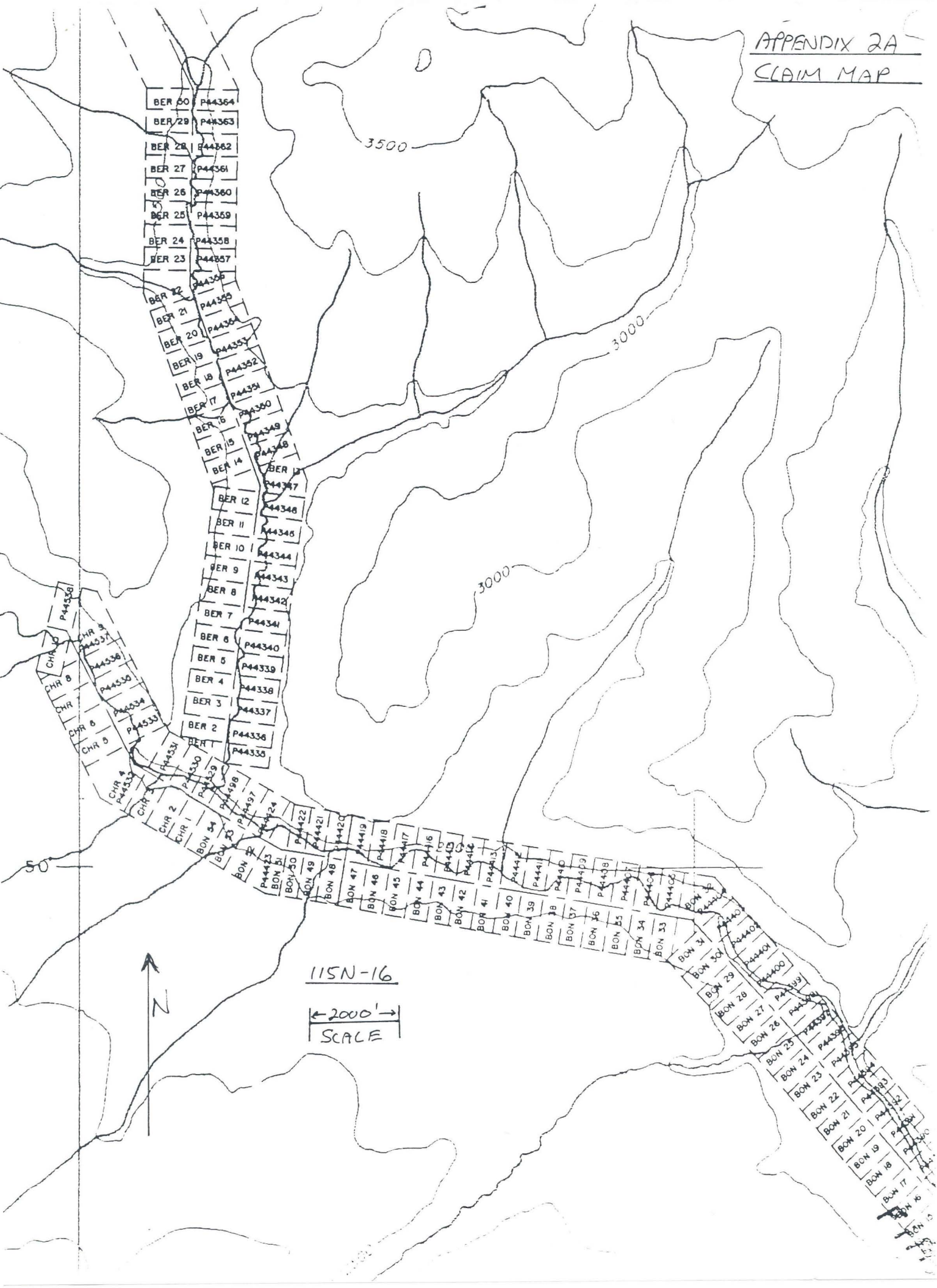

115N-16  
← 2000' →  
SCALE

APPENDIX 2B  
CLAIM MAP

50

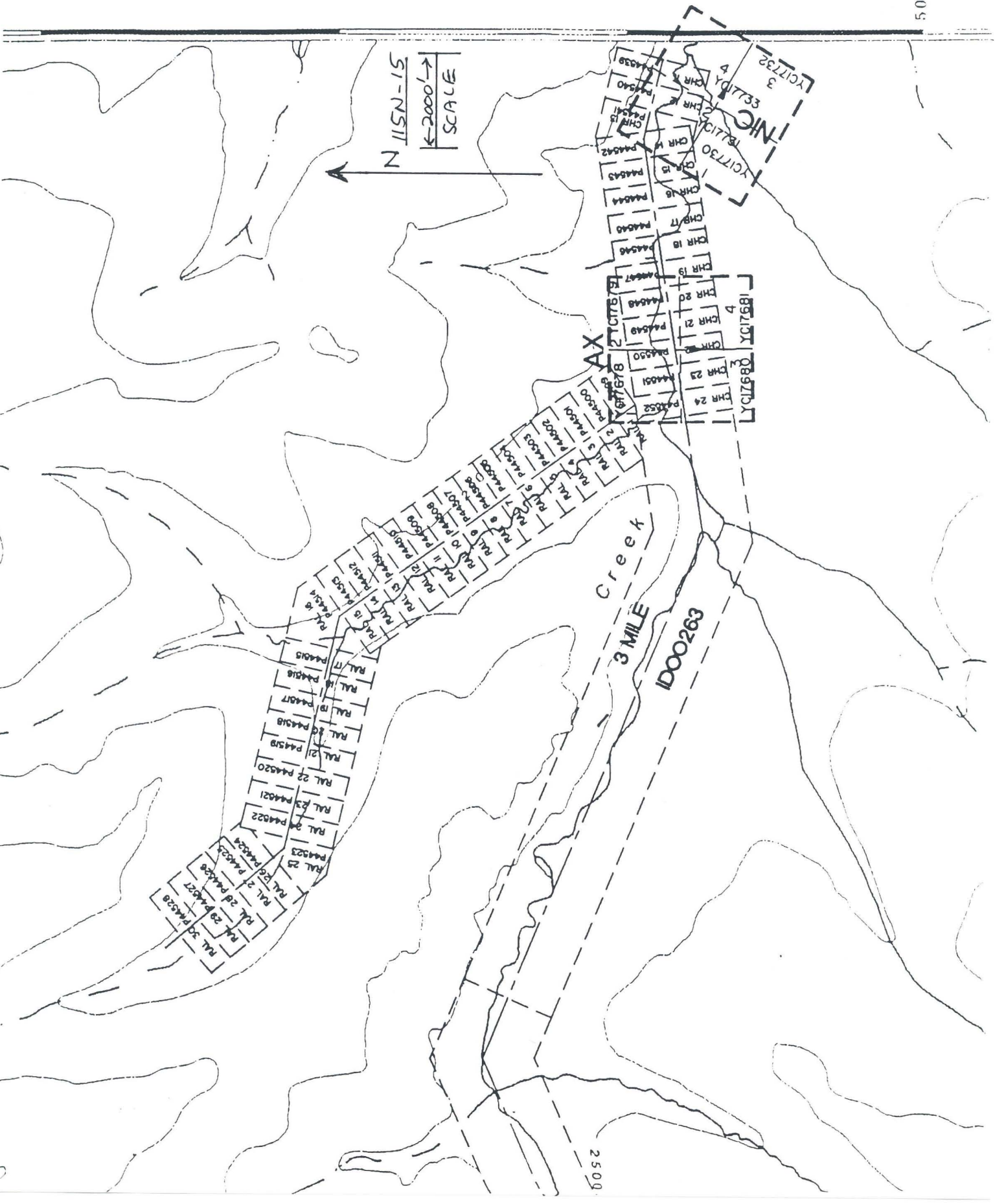

## STATEMENT OF QUALIFICATIONS

February, 2001

- *Albert Rudis* has 15 years of experience in exploration and evaluation of mining properties. 9 years of this was in Nevada, where for over five years he served as the President of Nevada International, Inc., a small Nevada mining exploration and development corporation.
- He also has extensive research and analytical experience with the U.S. Government, 5 years of which was in scientific research and development as an operations research analyst at a U.S. Navy Research and Development Laboratory.
- For the past six years Mr. Rudis has lived in Dawson City, Yukon. During this period, he has been involved on a full time basis in placer mining and exploration, and hard rock prospecting. Beginning in 1995, Mr. Rudis conducted in-depth research into historical and modern placer mining techniques and properties. He has defined several areas where new techniques can be applied to profitably mine lower grade historical and new placer areas.
- Mr. Rudis has assisted and advised local miners on a voluntary basis as requested, and has consulted with select local placer miners with emphasis on ground evaluation, processing plant effectiveness, and drilling procedure. Consultation projects have involved:
  - Application of the latest sluice box technology.
  - Location of unrecognized profitable mining zones and procedure in the Dawson historical placer area.
  - Economic viability of new placer and hard rock mining ventures.
- He is a Partner in the prospecting, exploration, and development of several groups of quartz and placer mining claims in the Yukon Territory, Canada.
- Mr. Rudis has a BS degree in Geology from Trinity College, Connecticut, and an MBA from the University of Oregon. He attended and took at the Geoscience Forum in Whitehorse in 1998, 1999 and 2000. In each forum he took the short course that was available. Mr. Rudis also attended the Dawson City Gold Shows in 1996, 1997, 1998, 1999, and 2000. He attended the available technical forums and presentations at each Gold Show.



Albert W. Rudis  
February 18, 2001

APPENDIX 3:

RALPH NORDLING

STATEMENT OF QUALIFICATIONS

February, 2001

- *Ralph Nordling* is an academically trained geologic technician, with job experience in both field sampling and geophysics. He has worked in mining equipment operations and maintenance for several major local placer miners, and for several years at the underground hardrock mine at *Keno, Yukon*.
- Mr. Nordling has a family heritage in Klondike Placer mining that extends back to the gold rush. He grew up as part of a successful family operated placer operation, and has over 20 years of hands-on placer mining experience, in both operating and maintaining equipment. During that time he was also responsible for evaluating the ongoing placer operations, determining pay zones, and evaluating the effectiveness of the mining operation.
- Mr. Nordling is familiar with all aspects of Placer Mining and Hard-Rock Mining from ground exploration and evaluation, to development and production. He attended the Geoscience Forum in Whitehorse in 1998. He has also attended the Dawson City Gold Show consecutively as it has been available.
- He is a Partner in the prospecting, exploration, and development of several groups of quartz and placer mining claims in the Yukon Territory, Canada.

Ralph Nordling

February 18, 2000

APPENDIX 4:  
COST CERTIFICATION

Helicopter:	4170.71
Truck (3X224kmX.42)	282.24
<b>Magnetometer Rental and Partial Analysis:</b>	
Amerok Geosciences Magnetometer Rental	770.40
Amerok Analysis of Cheryl Creek Line	1177.00
Amerok Report Copies and Grid Printouts	441.38
<b>Satellite Phone Rental:</b>	
Total North	438.43
<b>Lap Top Computer Rental:</b>	
Jay Armatage	200.00
<b>Contract Labour:</b>	
Claude Audit	1610.00
Tim Gunter	1645.00
Bonnie Nordling	225.00
Shawn Ryan	<u>1650.00</u>
<b>SUBTOTAL:</b>	<b>5130.00</b>
<b>Crew Chief and Geologic Technician:</b>	
Ralph Nordling (325 X 6):	1950.00
<b>Project Manager:</b>	
Al Rudis (400 X 7)	2800.00
<b>Worker's Compensation:</b>	393.70
<b>Shipping Critical Items:</b>	104.27

Fuel:	78.31
Parts and Supplies:	201.10
Sample Cost:	300.00
Food and Camp Supplies:	1260.00
Equipment Rental:	
Chain Saw:	180.00
Generator:	140.00
Report Preparation: (6 X 400)	<u>2400.00</u>
Overall Total:	\$22,417.54

Certified to be a True and Accurate Cost of this Project:

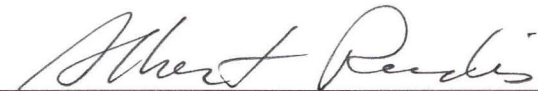
Al Rudis 

18 February 2001

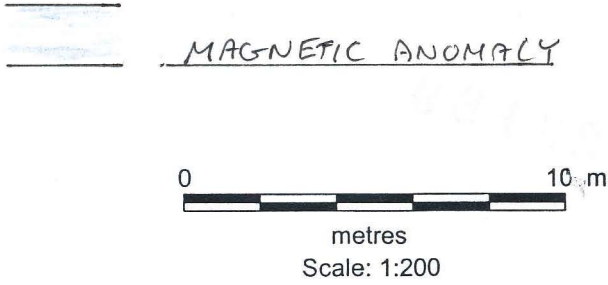
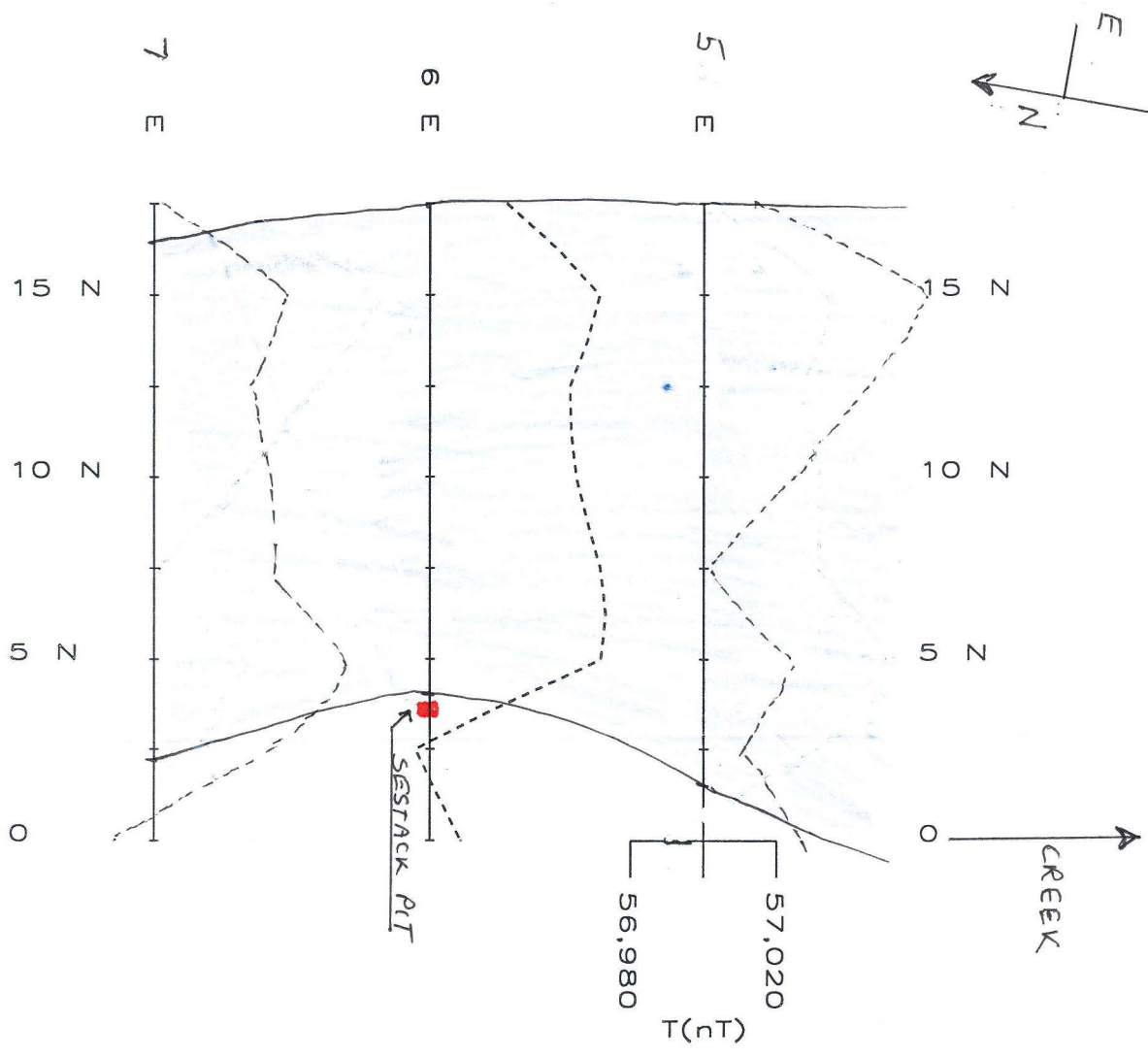

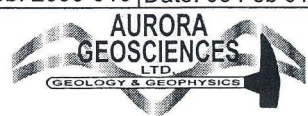
AL RUDIS	<b>SESTACK PIT</b>	
	NTS: 115 N/16	Datum: NAD 27
<b>TOTAL MAGNETIC FIELD STACKED PROFILES FIGURE</b>	Mining District: DAWSON	
	Job: 2000-016	Date: 05 Feb 01
	 <b>AURORA GEOSCIENCES LTD.</b> <small>GEOLOGY &amp; GEOPHYSICS</small>	

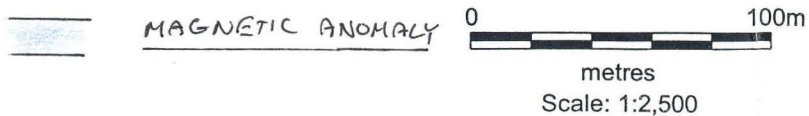
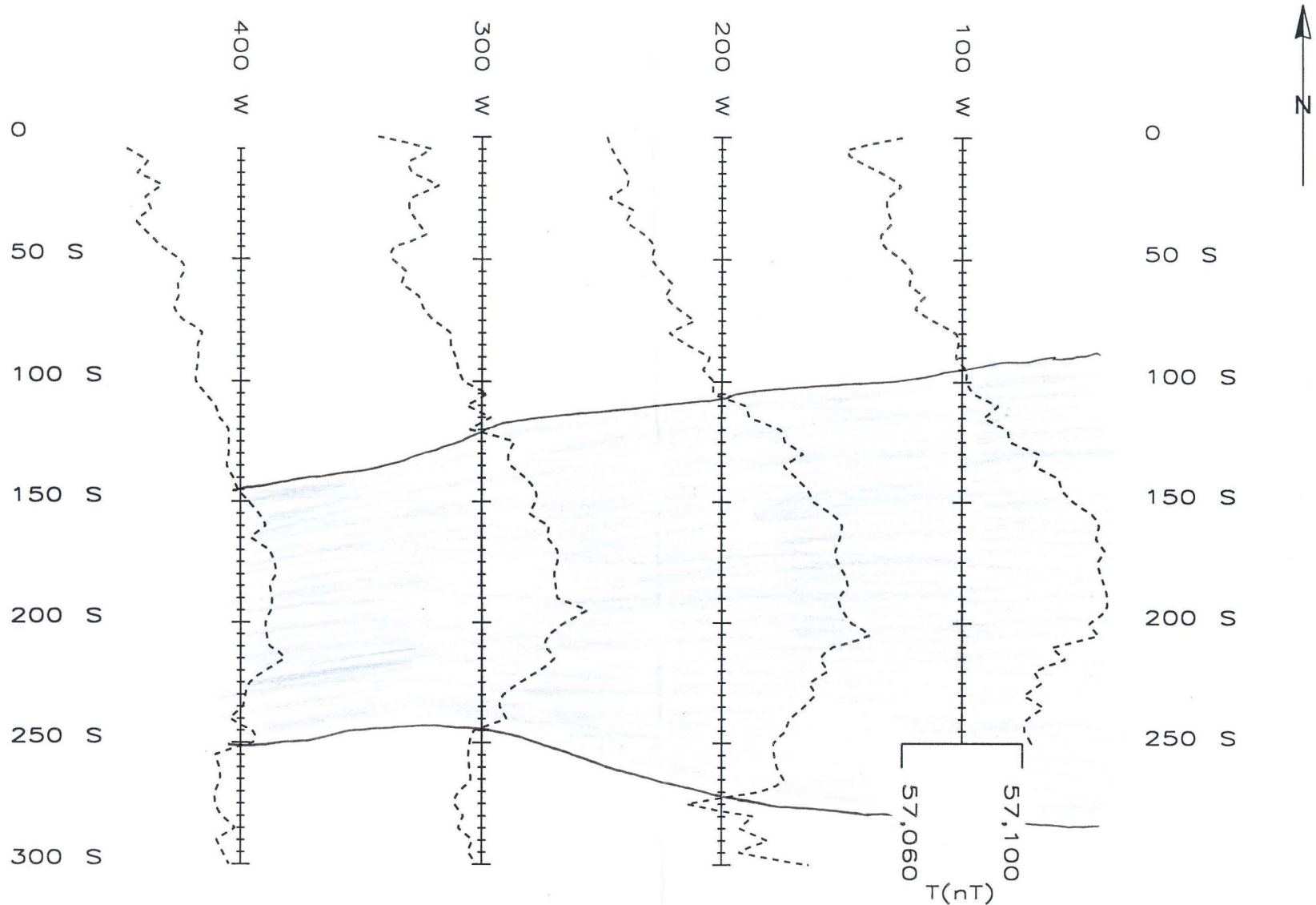

<b>AL RUDIS</b>	<b>50 MILE TERRACE</b>	
	NTS: 115 N/16	Datum: NAD 27
TOTAL MAGNETIC FIELD STACKED PROFILES FIGURE		
Mining District: DAWSON		Job: 2000-016   Date: 06 Feb 01

ENT 4. GRID LOCATIONS

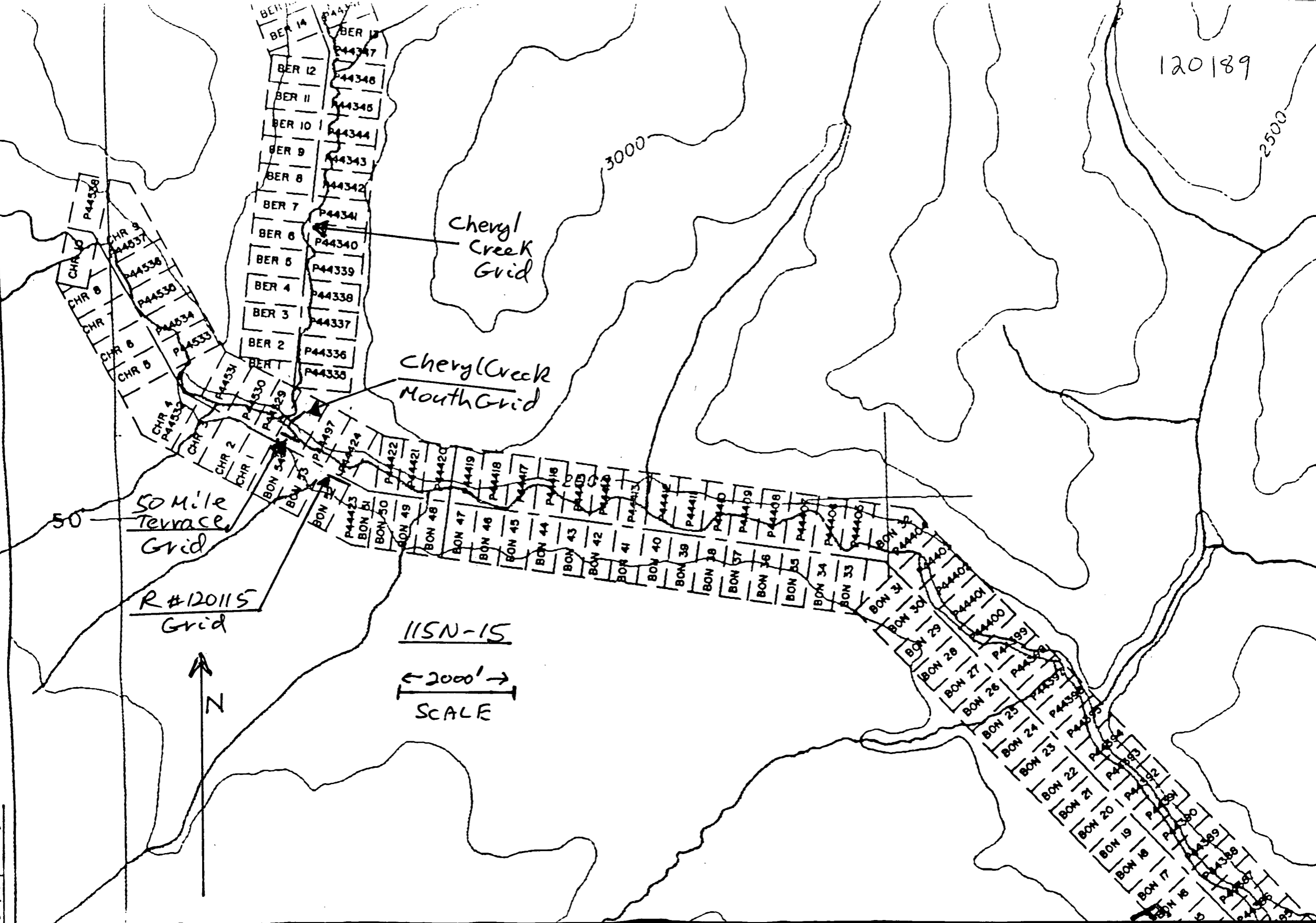

120189

3000

2500

Cheryl Creek Grid

Cheryl Creek Mouth Grid

50 Mile Terrace Grid

R#120115 Grid

115N-15

← 2000' →  
SCALE

N

240 S  
280 S  
320 S  
360 S  
400 S  
440 S  
480 S  
520 S  
560 S  
600 S  
640 S  
680 S  
720 S  
760 S  
800 S  
840 S  
880 S  
920 S

200 S  
240 S  
280 S  
320 S  
360 S  
400 S  
440 S  
480 S  
520 S  
560 S  
600 S  
640 S  
680 S  
720 S  
760 S  
800 S  
840 S  
880 S  
920 S

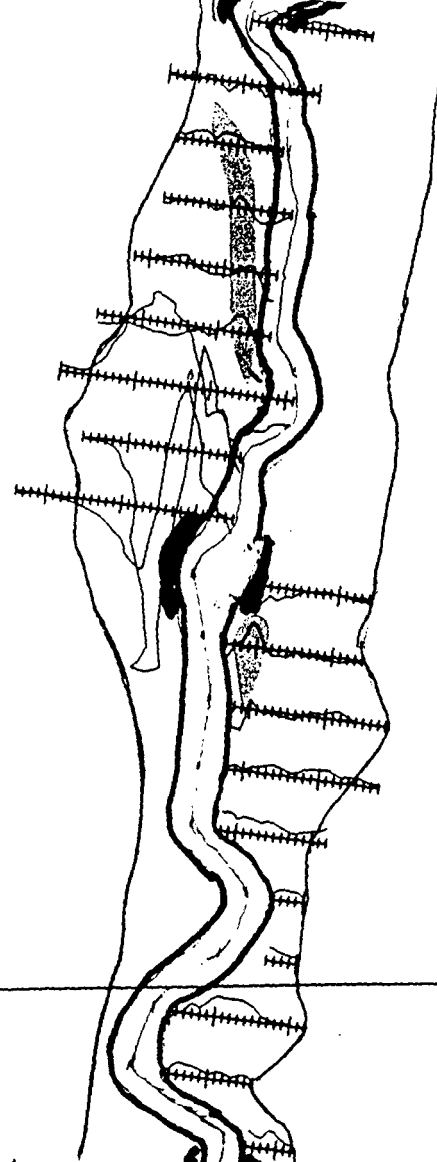

Set Back 10m      Set Back 10m  
High Water

100 W    50 W    0    50 E    100 E    150 E

526,000 E

ATTACHMENT 5

SCALE: 1:5000

120189

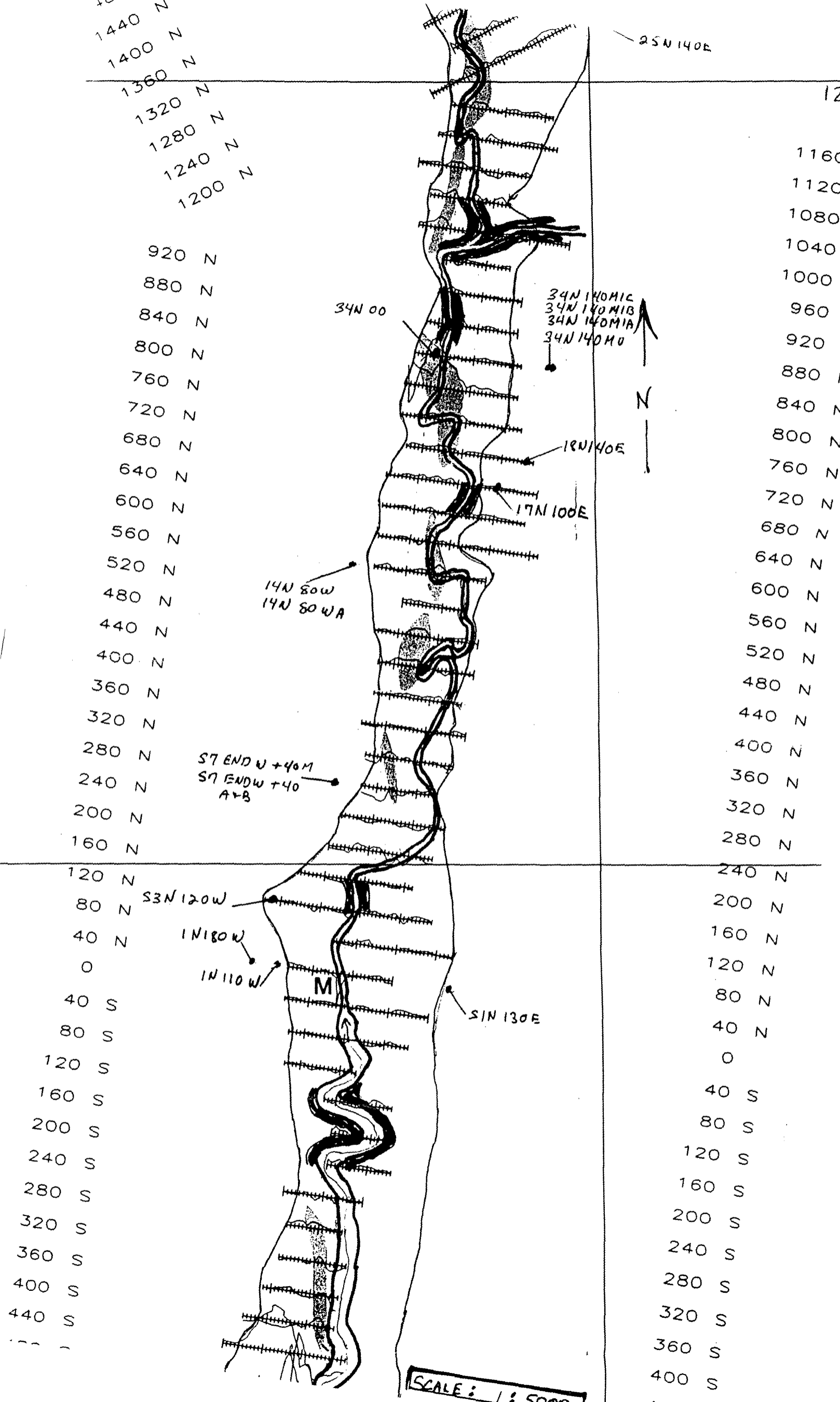

50 W  
0  
50 E  
100 E  
150 E  
200 E  
250 E

2400 N  
2360 N  
2320 N  
2280 N  
2240 N  
2200 N  
2160 N  
2120 N  
2080 N  
2040 N  
2000 N  
1960 N  
1920 N  
1880 N  
1840 N  
1800 N  
1760 N  
1720 N  
1680 N  
1640 N  
1600 N  
1560 N  
1520 N  
1480 N  
1440 N  
1400 N  
1360 N  
1320 N  
1280 N  
1240 N  
1200 N

2400 N  
2360 N  
2320 N  
2280 N  
2240 N  
2200 N  
2160 N  
2120 N  
2080 N  
2040 N  
2000 N  
1960 N  
1920 N  
1880 N  
1840 N  
1800 N  
1760 N  
1720 N  
1680 N  
1640 N  
1600 N  
1560 N  
1520 N  
1480 N  
1440 N  
1400 N  
1360 N  
1320 N  
1280 N  
1240 N  
1200 N

Side Hill → Flat to Moderate Gradient ← Side Hill

POST 2 BER 18  
POST 2 BER 18 RIVER



SCALE : 1:5000

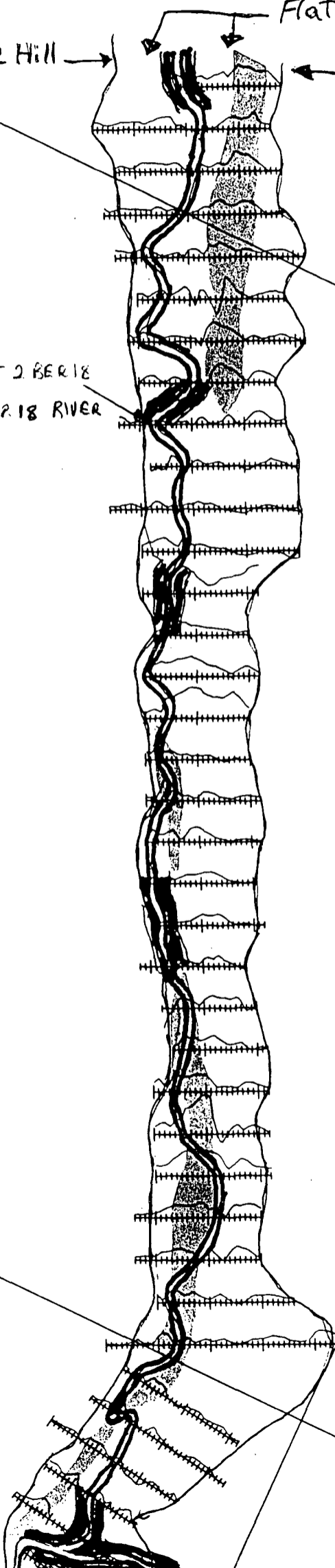

**AL RUDIS**

**TOTAL MAGNETIC FIELD SURVEY  
OF THE CHERYL CREEK PROPERTY,  
FIFTY MILE RIVER AREA,  
YUKON TERRITORY**

M.A. Power  
**AMEROK GEOSCIENCES LTD.**

CLAIMS  
BER 1 - 30P44335 - P44364

120189

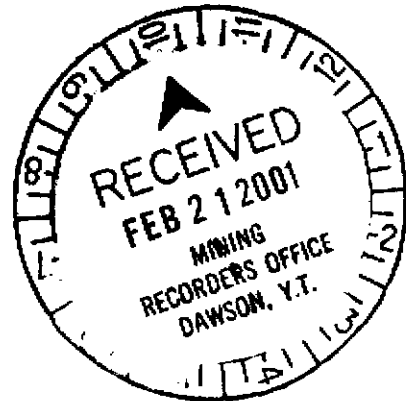

Location: 63° 51'N, 140° 30'W  
NTS: 105 N 16  
Mining District: Dawson, Y.T.  
Date: October 24, 2000

## **SUMMARY**

A total magnetic field survey was conducted on the Cheryl Creek Property in the Fifty Mile River area, western Yukon to locate auriferous gravels in the creek bed. The survey was conducted by a one man crew between August 20 to 25, 2000. The crew covered 10.5 line km on 84 lines, surveying at a 5 m station spacing over a flagged grid centred on the creek centre line. The survey was conducted with a pair of proton precession magnetometers using one instrument as a base station and the second as the field unit. All field data was corrected for temporal geomagnetic variation using the base station. The survey identified several anomalies which could be caused by bedrock or placer magnetite sources.

**TABLE OF CONTENTS**

1.0 INTRODUCTION ..... 1

2.0 LOCATION AND ACCESS ..... 1

3.0 PROPERTY ..... 1

4.0 PHYSIOLOGY AND PLACER GEOLOGY ..... 1

5.0 SURVEY GRID ..... 2

6.0 PERSONNEL AND EQUIPMENT ..... 2

7.0 SURVEY SPECIFICATIONS ..... 3

8.0 MAGNETIC FIELD THEORY ..... 3

9.0 RESULTS ..... 4

10.0 CONCLUSIONS AND RECOMMENDATIONS ..... 5

References Cited ..... 6

APPENDIX A. CERTIFICATE ..... 7

APPENDIX B. INSTRUMENT SPECIFICATIONS ..... 8

APPENDIX C. STATEMENT OF EXPENDITURES ..... 9

## LIST OF FIGURES

Figure 1. Property location .....	Following page 1
Figure 2. Grid location .....	Following page 1
Figure 3. Total magnetic field modelling results .....	Following page 3
Figure 4. Total magnetic field stacked profiles .....	Back pocket
Figure 5. Total magnetic field contour map .....	Back pocket

## 1.0 INTRODUCTION

Amerok Geosciences Ltd. was retained by Al Rudis to conduct ground total magnetic field surveys on the Cheryl Creek Property. A total of 10.52 line-km of grid were surveyed between August 20 and 25, 2000. The surveys were conducted to locate auriferous placer deposits associated with magnetite along the creek. This report describes the survey specifications and operations, data and contains an interpretation of the results.

## 2.0 LOCATION AND ACCESS

The Cheryl Creek Property is centred at 63° 51'N, 140° 30'W, on Cheryl Creek, in the Fifty Mile River area of the western Yukon Territory. The property is located approximately 55 km southwest of Dawson City, Yukon (Figure 1). The property is accessible by helicopter from Dawson City.

## 3.0 PROPERTY

The Cheryl Creek Property consists of 30 un-surveyed placer claims staked under the Yukon Placer Mining Act in the Dawson Mining District, Yukon Territory. Claim information<sup>1</sup> is summarized below:

<u>Claim</u>	<u>Grant No.</u>	<u>Owner</u>	<u>Expiry date</u>
BER 1-30	P44335 - P44364	Ralph Nordling (100%)	August 23, 2001

Claim locations as shown on government claim maps and the location of the survey grid are shown in Figure 2.

## 4.0 PHYSIOLOGY AND PLACER GEOLOGY

The geology and physiology of the area containing the Property has been described by Cockfield (1921) and Gordey and Makepiece (1999). The property is located in the Yukon Plateau, south of the Tintina Trench at elevations ranging from 600 to 1000 m. The area is subject to continental climatic conditions with short, warm summers and cold winters. Temperatures range from 15 to 25° C during the summer period and down to -50° C during the coldest months of winter.

---

<sup>1</sup> Claim information per Claim Status Report by the Dawson Mining Recorder on October 24, 2000

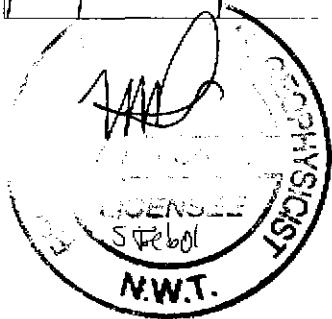
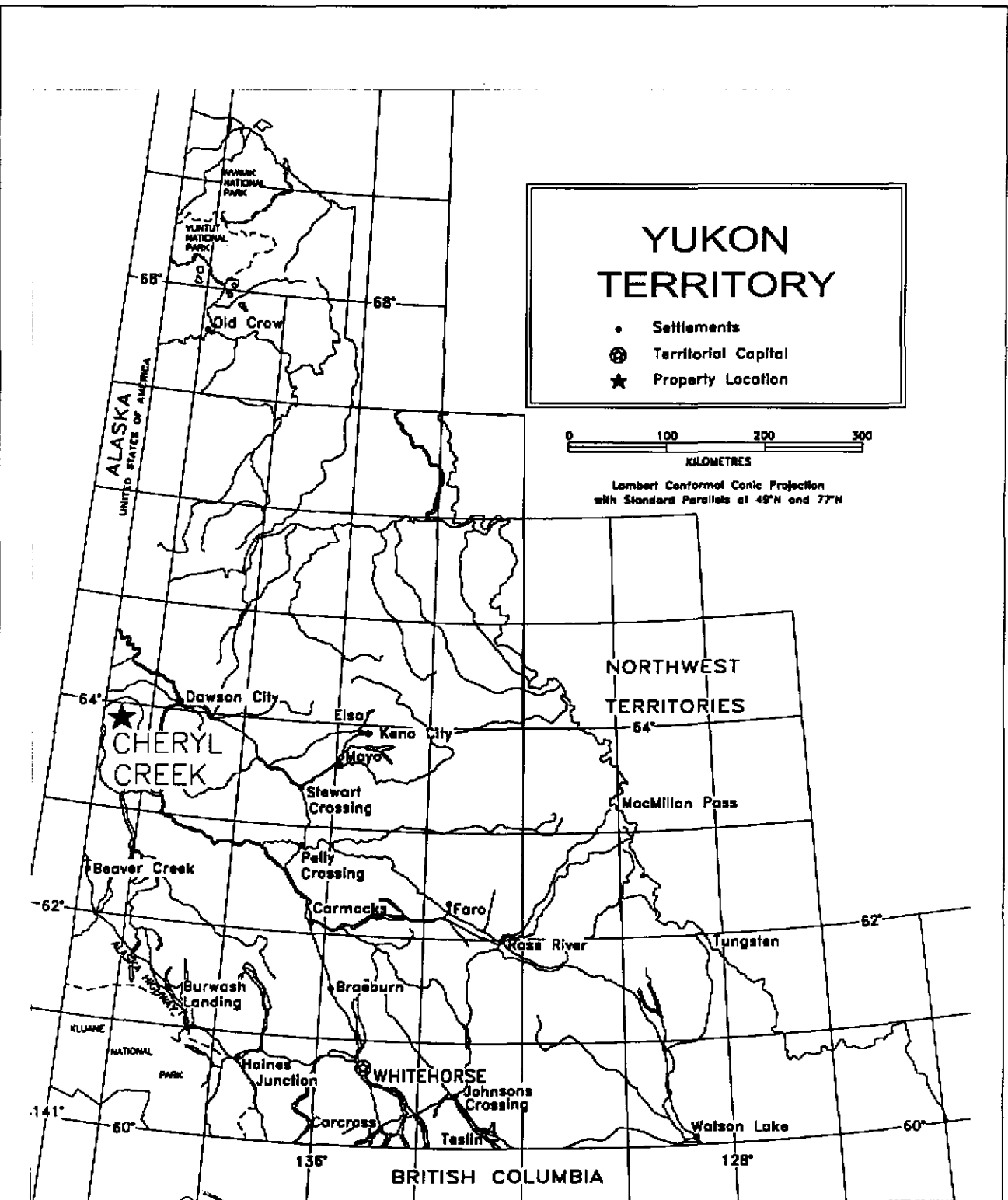

AL RUDIS	CHERYL CREEK PROPERTY	
PROPERTY LOCATION	MINING DISTRICT: DAWSON	
	NTS: 115 N/16	SCALE 1: 6 000 000
Amerok Geosciences Ltd.	DRAWN BY: HDS	
	DATE: 2000.10.16	FIGURE: 1

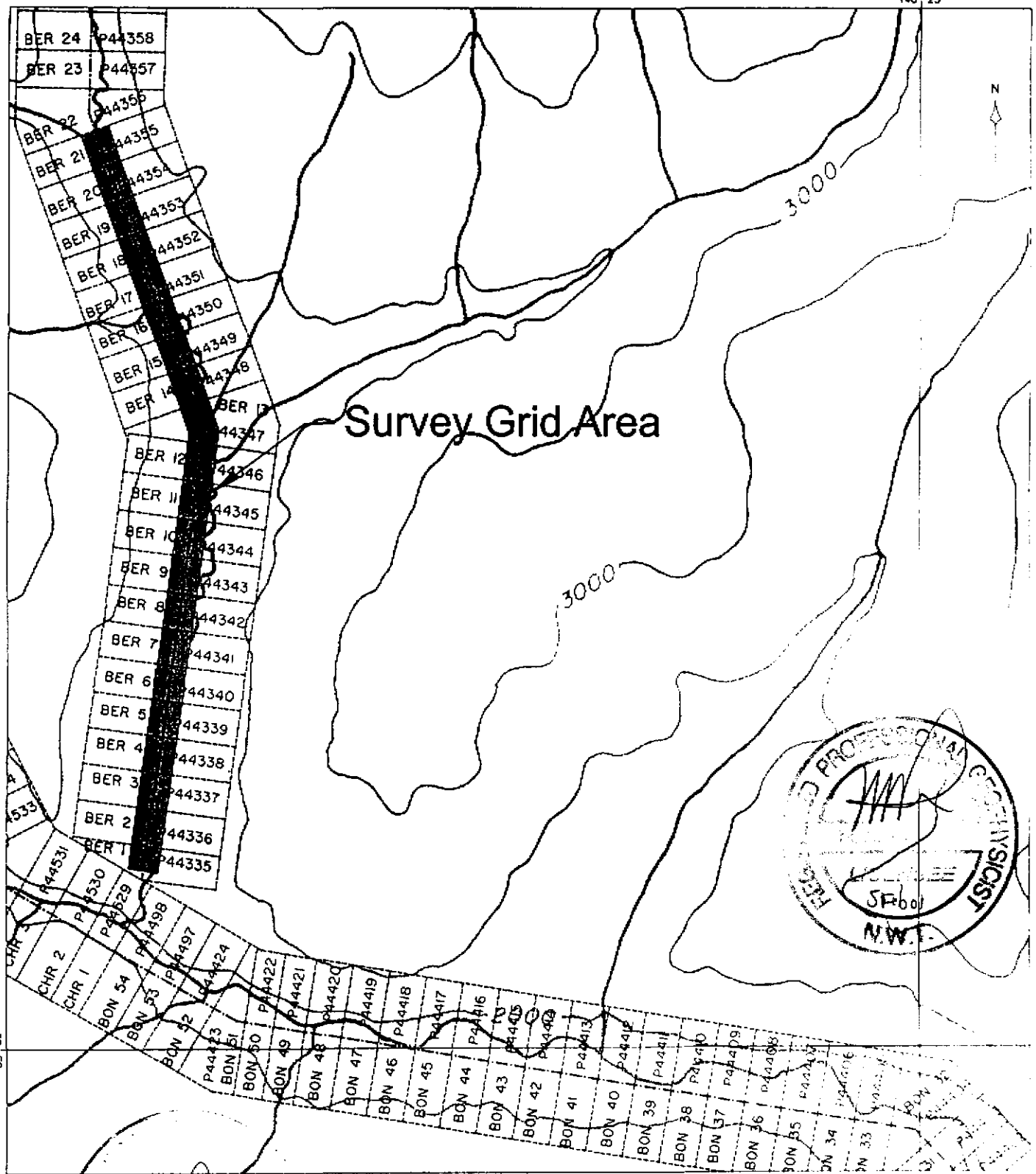

Survey Grid Area

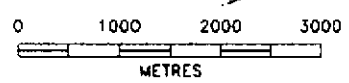
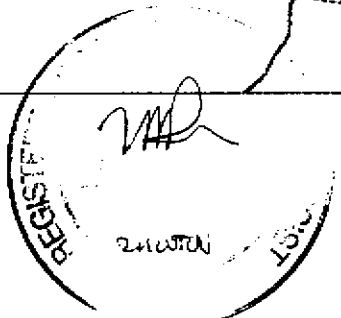
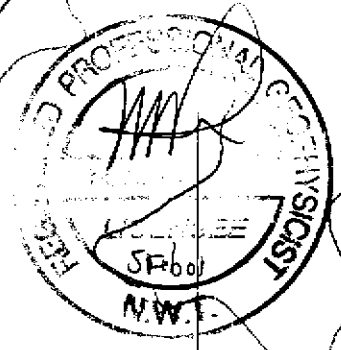

AL RUDIS		CHERYL CREEK PROPERTY	
CLAIM LOCATION		MINING DISTRICT: DAWSON	
		NTS: 115 N/16	SCALE 1: 7 500
Amerok Geosciences Ltd.		DRAWN BY: HOS	
		DATE: 2000 10 17	FIGURE 2

The Cheryl Creek property is underlain by two rock units. To the north of L1190N, the property is underlain by metamorphosed mafic rocks including amphibolite and ultramafic rocks belonging to the Nisling, Nasina, and Slide Mountain assemblages. These rocks appear to strike east-west based on their aeromagnetic signature. South of L1190N, the property is underlain by orthogneiss of the Fifty Mile Batholith. The intrusive rocks have a very subdued aeromagnetic signature. Residual magnetite in placer deposits on Cheryl Creek is likely derived from the northern rock unit.

There are no hard rock showings on Cheryl Creek indicated by the Yukon Minfile. Several significant showings occur elsewhere in the area. The Butler Showing (115N42) is 7 km NW of the Cheryl Creek Property and contains vein hosted Pb-Ag-Au mineralization in metasediments. The Connaught Showing (115N40) consists of galena and sphalerite with minor sphalerite, tetrahedrite and boulangerite in a series of northeast striking quartz veins along the contact between the Fifty Mile Batholith and the intruded mafic metamorphic rocks. Shipments of hand cobbled ore were made from both showings during the 1966 and 1976 which averaged approximately 2200 g/t Ag and 1.0 g/t Au.

Cockfield (1921) describes the regional placer geology. The property occurs in a large area of the western Yukon which escaped Quaternary glaciation. Placer gold occurs in pre-glacial valley-bottom gravels and in benches or terraces along the streams. Gravels are described as poorly sorted and consisting of cobbles and pebbles (to 10 cm) of metamorphic rocks overlain by loess and lesser sand and gravel. The bench deposits occur at a higher elevation and have a lower average gradient indicating that the present stream channel gravels formed through reworking of older deposits and down-cutting associated with regional uplift.

## **5.0 SURVEY GRID**

The geophysical surveys were conducted on a flagged grid centred on Cheryl Creek. The base line (BL 0E) runs along the main channel of Cheryl Creek for 3.2 line-km at an azimuth of 190° south of L1190N and at an azimuth of 158° north of this location. The grid consists of 10.50 line-km along 84 survey lines. Lines were hip chained, not slope corrected and flagged at intervals suitable for the survey.

## **6.0 PERSONNEL AND EQUIPMENT**

The surveys were conducted by the following personnel:

Sean Ryan

c/o Box 887  
Dawson City, YT Y0B 1G0

He was equipped with the following instruments and equipment:

Instruments:            1 - GEM Overhauser magnetometer  
                                 1 - GEM Proton precession magnetometer

The geophysical crew spent a total of 6 days on the property. Instrument specification are attached in Appendix B.

## 7.0 SURVEY SPECIFICATIONS

The magnetometer survey was conducted according to the following specifications:

Station spacing:        5 m

Base station:            Installed on the survey grid and cycled at 5 s throughout the survey.

## 8.0 MAGNETIC FIELD THEORY

Magnetic field theory is well described in standard texts (eg. Telford *et. al.* 1990). In a placer setting, magnetite derived from bedrock weathering is concentrated in the main channel of a creek or river (thalweg) where the water flow has the highest velocity and greatest turbulence. As a result, minerals with high specific gravity (magnetite, ilmenite, gold, etc.) are preferentially concentrated in this region of the stream bed as material with lower specific gravity is winnowed from the sediment. High concentrations of "black sand" (magnetite, ilmenite, chromite) are often recorded in auriferous pay streaks where the stream bed has remained relatively immobile for some period, permitting hydraulic concentration to build up a significant volume of these minerals.

The materials comprising black sand are magnetically susceptible. Magnetite has a very high magnetic susceptibility of  $1200-19200 \times 10^{-3}$  SI units and ilmenite ranges from  $300-3500 \times 10^{-3}$  SI units. Average magnetic susceptibilities for sedimentary, igneous (excluding ultramafic) and metamorphic rocks are 0-18, 3-160 and  $0-70 \times 10^{-3}$  SI units and the magnetic susceptibility of fluvial sediments is in the range  $0-2 \times 10^{-3}$  SI units. There is consequently a susceptibility contrast between gravels with elevated concentrations of black

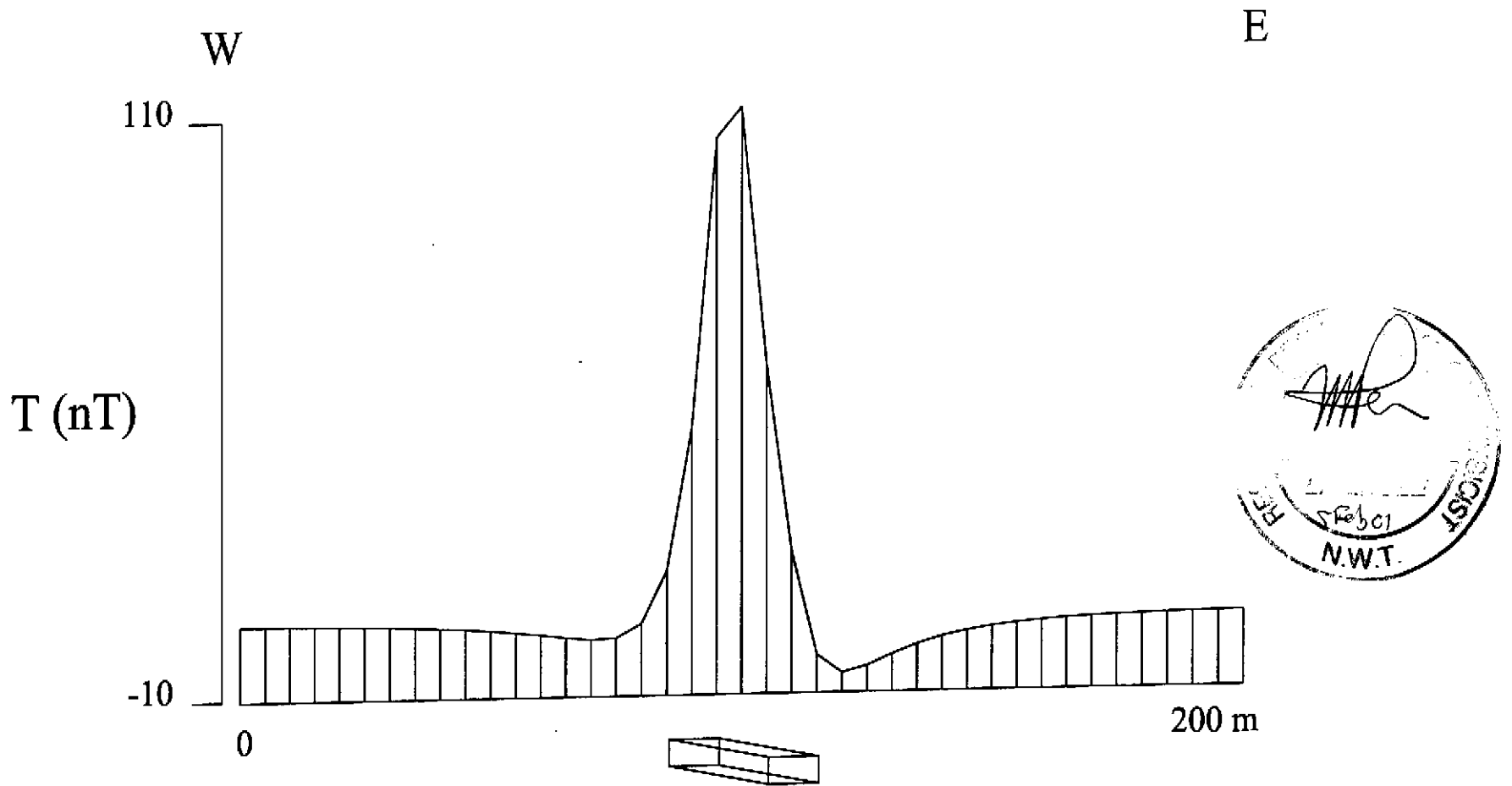

Placer deposit model  
 Dimensions: 50 m (NS) x 10 m (EW) x 5 m (thick)  
 Strike: N (0°)  
 Susceptibility contrast: 0.003 SI units

Figure 3. Magnetic model for a placer channel on Cheryl Creek, YT.

sand, and both bedrock and average gravels. In the author's experience, most placer magnetic field anomalies are of low amplitude, in the range of 50 to 200 nT.

A knowledge of expected magnetic responses on the property is useful in interpreting the data. Forward models of typical magnetic responses for a placer deposit at Cheryl Creek were generated using Geopak REVS software to determine the signature of a prospective target on the property. The models incorporate the local earth field described by the International Geomagnetic Reference Field (IGRF) for the time and location of the survey. Field parameters were calculated using the United States Geological Survey program IGRFPT and are summarized below:

Total field strength:	57,332 nT
Inclination:	77.80°
Declination:	28.86° E

As an approximation of a placer deposit, a rectangular slab with dimensions of 50m (N-S) by 10 m (E-W) by 5 m thick oriented with a long axis pointing north was used in the modeling. A magnetic susceptibility contrast of  $3 \times 10^{-3}$  SI units has been inferred. The orientation of the slab and of an E-W survey line across it are shown in Figure 3.

The response of a placer deposit in this setting would likely consist of a central peak with asymmetric flanking trough responses. The central peak is located over the centre of the deposit or slightly (2 to 4 m) magnetically east of the centre of the source body. The half amplitude point on the east side of the anomaly occurs over the east side of the source body. The break in slope of the flat top of the anomaly on the west side occurs is coincident with the west edge of the source body. If the source body is at a depth greater than its thickness (eg. 5 m thick at 15 m depth), the flanking troughs will be absent and the response will be much smoother. The amplitude of the response is proportional to the magnetite content but does not influence the shape of the anomaly. Neither the thickness nor depth to top can be determined accurately without complementary geophysical techniques. The total magnetic field data is best used for indicating the surface projection of magnetic sources which may be of potential economic interest and is of comparatively little use in deriving information on the geometric parameters of the source body.

## 9.0 RESULTS

Digital data is appended to this report on disk. The magnetic field data is in the

following format:

Line Station UTM\_E UTM\_N Corr\_field

where Corr\_field is the corrected magnetic field.

The following plots at 1:5,000 are appended to this report in the back pockets:

Figure 4. Total magnetic field stacked profiles

Figure 5. Total magnetic field contour map

Each plot shows the survey grid in nominal (ie. uncorrected) coordinates with the small ticks indicating the reading station location and the larger ticks at 50 m intervals coincident with the station labels. The stacked profiles display the total magnetic field (in red) with an increasing field trending above the survey line. The total field contour map displays the total field amplitude according to a blue to red colour scheme illuminated from a shallow easterly sun angle to highlight total magnetic field trends parallel to the stream drainage.

The total magnetic field survey identified a series of anomalies in the creek bed which could be caused by concentrations of placer magnetite. Many of these lack flanking troughs suggesting that the deposits are deeper than they are thick. The possible locations of placer magnetite sources are identified in blue in Figure 4. The shaded total field map in Figure 5 shows additional features, including a change in total field amplitude roughly coincident with both the bend in the base line and the location of the inferred contact between the metamorphic rocks and the Fiftymile Batholith.

## 11.0 CONCLUSIONS AND RECOMMENDATIONS

The results of the total magnetic field survey conducted on the Cheryl Creek property indicate the location of several anomalies which could be arise from placer magnetite concentrations. These anomalies should be investigated on the ground and tested by excavation if resources permit. Those anomalies with higher amplitudes and flanking negative anomalies should be investigated first.

Respectfully submitted,  
**AMEROK GEOSCIENCES LTD.**

Michael A. Power, M.Sc. P.Geo.  
Geophysicist

## References Cited

- Cockfield, W.E. (1921) Sixtymile and Ladue Rivers Area, Yukon. Ottawa: Geological Survey of Canada Memoir 123.
- Gordey, S.P and Makepeace, A.J. (1999) Yukon Digital Geology. Geological Survey of Canada Open File D3826.
- Telford, W.M., L.P. Geldart and R.E. Sheriff (1990) Applied Geophysics (2<sup>nd</sup> Edition) New York: Cambridge University Press.

## APPENDIX A. CERTIFICATE

I, Michael Allan Power, with residence and business address in Whitehorse, Yukon Territory do hereby certify that:

1. I hold a B.Sc. (Honours) in Geology granted in 1986 and M.Sc. in Geophysics granted in 1988, both from the University of Alberta.
2. I have been actively involved in mineral exploration in the northern Cordillera and in the Northwest Territories since 1988. I am a professional geoscientist registered with the Association of Professional Engineers and Geoscientists of British Columbia (Registration number 21131) and a Professional Geophysicist registered with the Northwest Territories Association of Engineers, Geologists and Geophysicists.
3. I supervised the geophysical surveys described in this report, interpreted the data collected and prepared this report.
4. I have no interest, direct or indirect, nor do I hope to receive any interest, direct or indirect, in the Cheryl Creek property.

Dated this 24<sup>th</sup> day of October 2000 in Whitehorse, Yukon Territory.

Michael A. Power, M.Sc. P.Geo.  
Geophysicist

## **APPENDIX B. INSTRUMENT SPECIFICATIONS**

## INSTRUMENT SPECIFICATIONS

### MAGNETOMETER / GRADIOMETER

Resolution:	0.0 InT (gamma), magnetic field and gradient.
Accuracy:	0.2nT over operating range.
Range:	20,000 to 120,000nT.
Gradient Tolerance:	Over 10, 000nT/m
Operating Interval:	3 seconds minimum, faster optional. Readings initiated from keyboard, external trigger, or carriage return via RS-232C.
Input / Output:	6 pin weatherproof connector, RS-232C, and (optional) analog output
Power Requirements:	12V, 200mA peak (during polarization), 30mA standby, 300mA peak in gradiometer mode.
Power Source:	Internal 12V, 2.6Ah sealed lead-acid battery standard, others optional. An External 12V power source can also be used
Battery Charger:	Input: 110 VAC, 60Hz. Optional 110 / 220 VAC, 50 / 60Hz Output: dual level charging.
Operating Ranges:	Temperature: -40°C to +60°C. Battery Voltage: 10.0V minimum to 15V maximum. Humidity: up to 90% relative, non condensing.
Storage Temperature:	-50°C to +65°C.
Display:	LCD: 240 X 64 pixels, OR 8 X 30 characters. Built in heater for operation below -20°C.
Dimensions:	Console: 223 x 69 x 240mm. Sensor Staff: 4 x 450mm sections. Sensor: 170 x 71mm dia. Weight: console 2.1kg, Staff 0.9kg, Sensors 1.1kg each
VLF	
Frequency Range:	15 - 30.0 kHz plus 57.9 kHz (Alaskan station)
Parameters Measured:	Vertical in-phase and out-of-phase components as percentage of total field. 2 relative components of horizontal field. Absolute amplitude of total field 0.1%.
Resolution:	Up to 3 at a time.
Number of Stations:	Automatic with: time, coordinates, magnetic field / gradient, slope, EM field frequency, in- and out-of-phase vertical, and both horizontal components for each selected station.
Storage:	
Terrain Slope Range:	0° - 90° (entered manually).
Sensor Dimensions:	140 x 150 x 90 mm. (5.5 x 6 x 3 inches).
Sensor Weight:	1.0 kg (2.2 lb).

9 V 1997

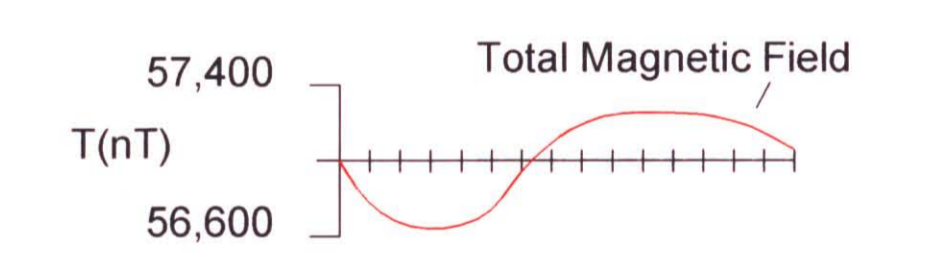
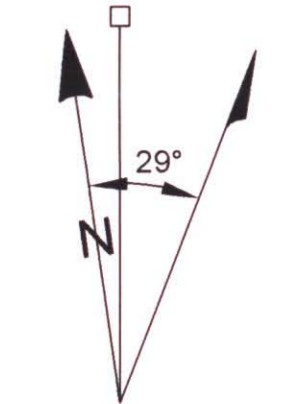
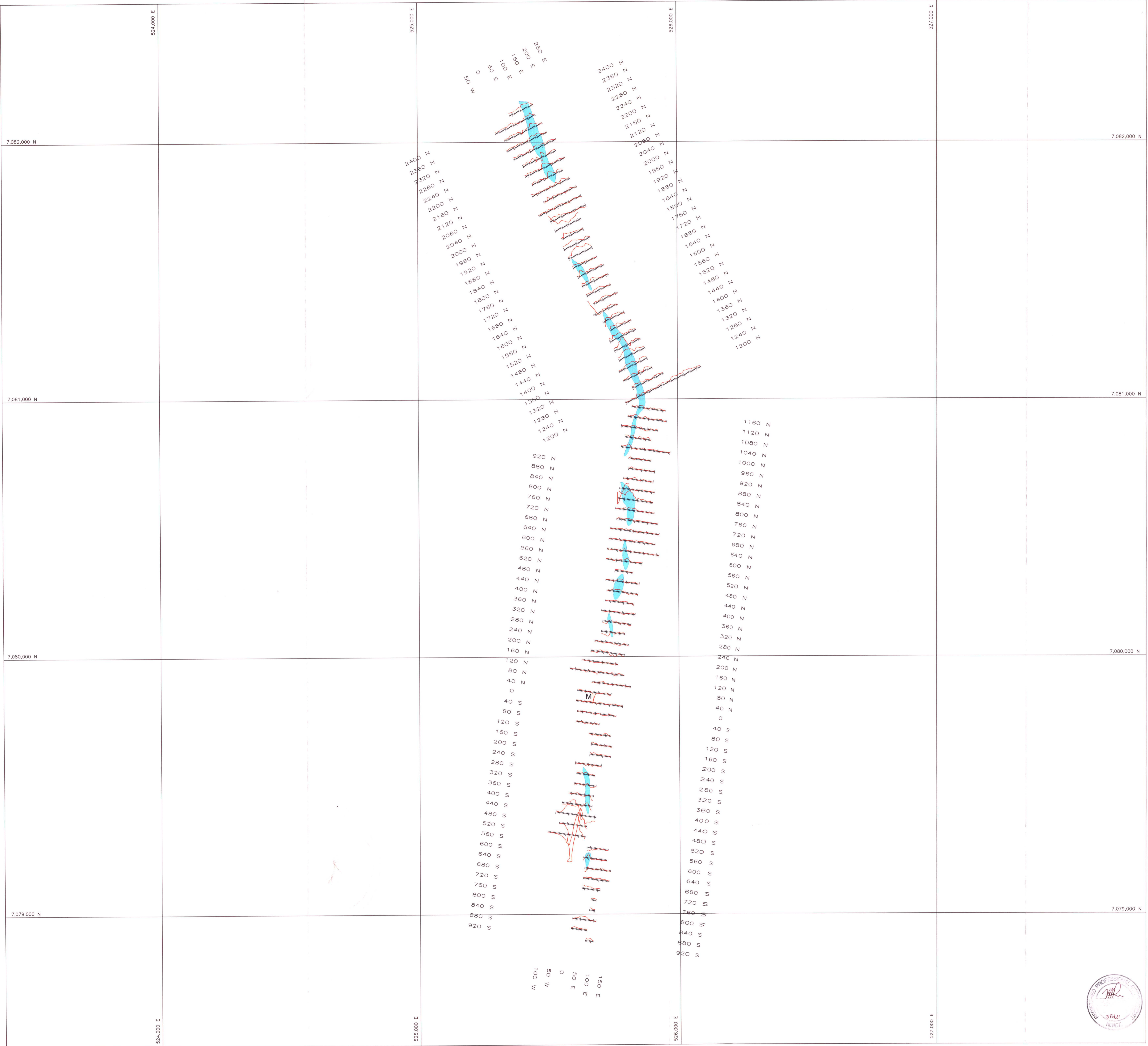

 MAGNETIC ANOMALY SOURCE

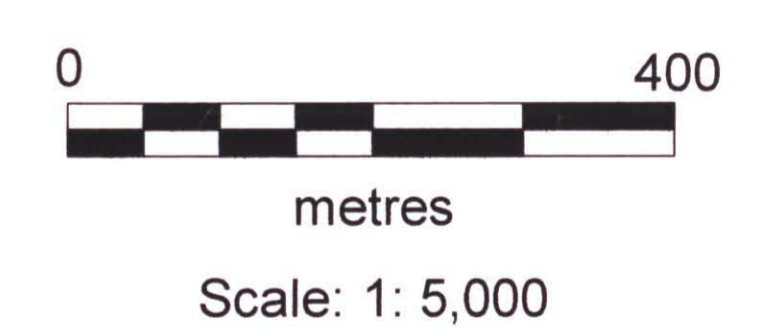

AL RUDIS

CHERYL CREEK PROPERTY

TOTAL MAGNETIC FIELD SURVEY  
 STACKED PROFILE  
 FIGURE 4. ①

NTS: 116 N/16 Datum: NAD 27  
 Mining District: Dawson  
 Job: 2000-016 Date: 24 October 2000



 120189  
 AMEROK GEOSCIENCES LTD.

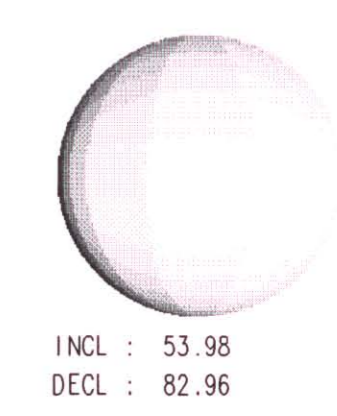
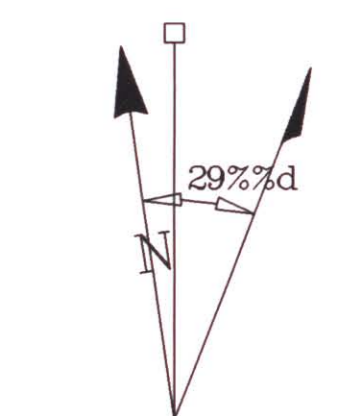
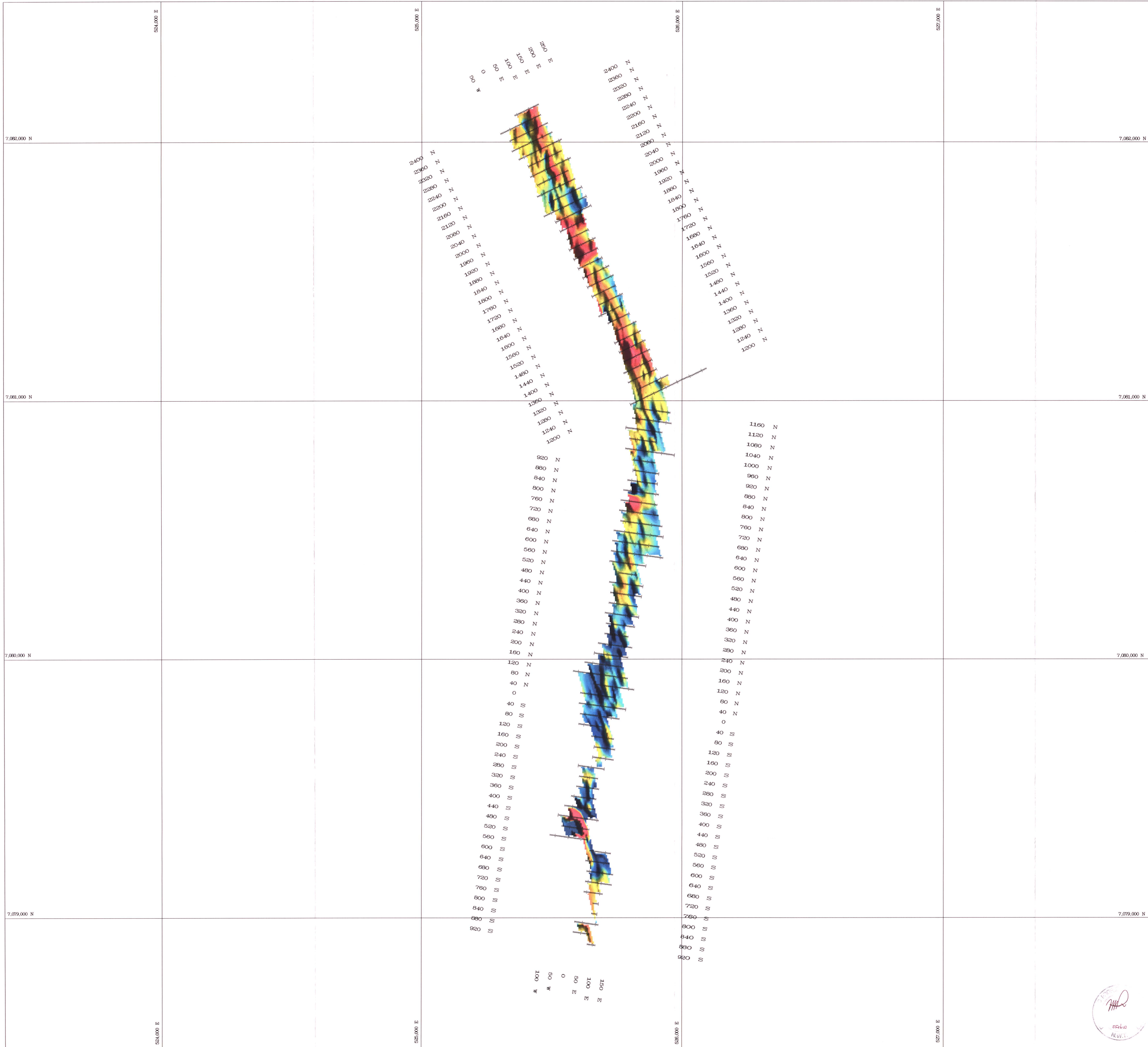

INCL : 53.98  
DECL : 82.96

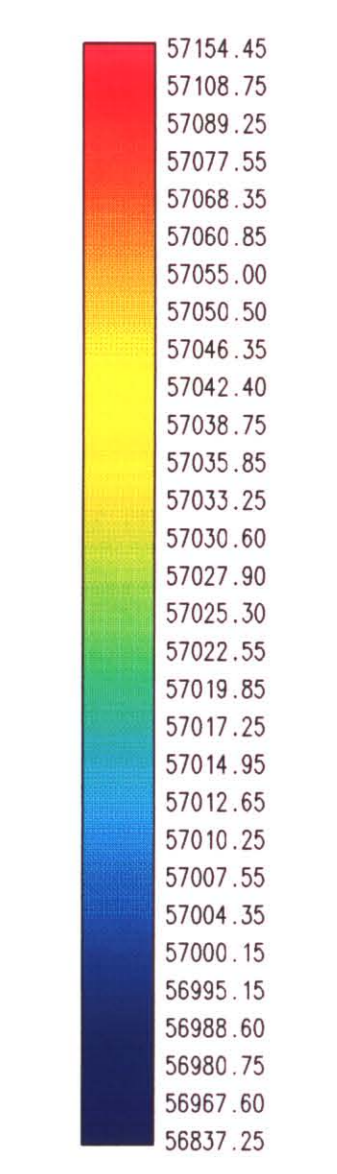

Total magnetic field (nT)

GRID CELL SIZE: 5 m  
FILTERS: 3-point

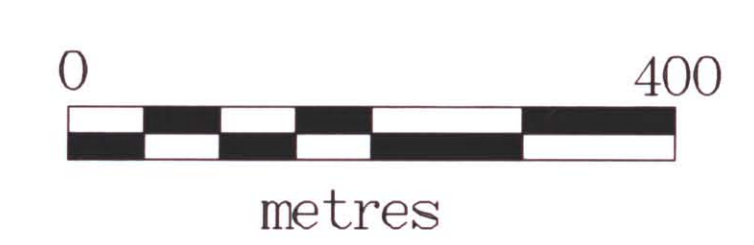

Scale: 1: 5,000

AL RUDIS

CHERYL CREEK PROPERTY

TOTAL MAGNETIC FIELD SURVEY  
CONTOUR MAP  
FIGURE 5.

NTS: 116 N/16 Datum: NAD 27

Mining District: Dawson, YT

Job: 2000-016 Date: 24 Oct 2000

AMEROK GEOSCIENCES LTD. 120189

