

Table of Contents ULTRA 2003

Summary of work done 2003

Aurora's Report with geophysical data, maps, and interpretations
(see Table of Contents in Aurora Report)

Claim Status of Claims in Renewal Request

Claim Map Showing Claim Renewal Location

Sample Location Map of 2003 Samples

Detailed Map of Froberg Showing 2001 & 2002 Sample Sites

Recommendations

Statement of Expenditures

Assay Sheets of VMS Samples and ULT Sample from Hand Trench of
Froberg

Qualifications of 19651 Yukon Inc.'s Principles

094465 V.1

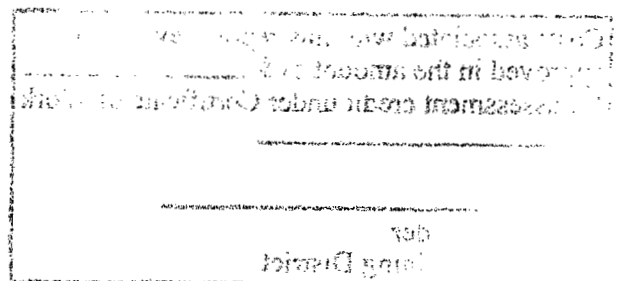

YUKON ENERGY, MINES
& RESOURCES LIBRARY
P.O. Box 2703
Whitehorse, Yukon Y1A 2C6

Costs associated with this report have been approved in the amount of \$ 14,600.00 for assessment credit under Certificate of Work No. QUS27654

H. Sawtuck
Mining Recorder
Vermont Horse Mining District

Summary of Work Ultra 2003

The program on the Ultra property consisted of line cutting, geophysics, minor trenching, pad building, sampling, and claim staking. A total of man – days went into accomplishing this. The start of work was in the spring with some infill staking of ULT 2 to ULT 7 claims on the upper portion of Telluride creek. After this work began again in September with blast trenching and pad building for the compressor. The compressor was then mobilized onto the site with jackleg, airline and related gear. Due to the limited availability of equipment and qualified personnel the max – min survey and line cutting took place next. The survey was cut short by a winter storm, coupled with safety concerns of some of the crews' inexperience with steep terrain and slippery conditions. After demobilizing camp and taking geophysicist and gear back to town, we came back to pack explosives and winter camp into the upper compressor site at the Froberg showing. Blizzard conditions came in a day later, causing us to pack up our camp and all the samples we could carry from the trench on the lower part of the showing, and head down the mountain. From the protected camp in the trees we made our way up to the lower VMS showing, after the severe conditions toned down a day later. We sampled and packed a couple hundred, plus pounds of massive sulfide boulder pieces from the creek to the ATV at the trailhead. We then packed up camp and headed back to town.

The last part of the program was an ill-fated staking attempt by skidoo and winter camp, in which ten days were spent to stake ten quartz claims, Ultra 81 to Ultra 90. Transportation of 100 posts into the claim area did occur at this time, which were flagged and GPSed. I was involved in the mobilization of guys, gear and posts, but was not on site while the job was happening, or during the demobilization. The property has been optioned and part of the deal is that peripheral ground is to be staked, which is currently happening at this time with helicopter support.

SAMPLE DESCRIPTIONS and RESULTS

A total of five sample sites were selected from the two showings on the Ultra property. Of these, one sample was from the Froberg showing at the head of Telluride / Cub creek and the other four were from the VMS boulders at the toe of the last distinct glacial moraine pile coming out of the upper Telluride / Cub creek circ area. *On claim ULT 1* ULT-01. This sample was from the lower part of the exposed outcrop of the Froberg showing. It was 0.5 meters of fractured chert with massive stock worked calchopyrite – pentlandite sulfide material within 2 meters of the Triassic gabbro unit, which dipped underneath the chert. The values received so far are not a true representative sample of the Pt& Pd results as this is an ICP assay. The full suite PGM nickel sulfide assay has not made it back at the present time. I feel this will give a more reliable value.

The values at present are 4.39%Cu, 0.48%Ni, 0.54ppmAu, 1.65ppmPt, and 7.09ppmPd. The Ni, Pt, and Pd values are low compared with the last sample taken here.

VMS-01. Laminated massive sulfide boulder with a large amount of iron stain leaching out of it. Calchopyrite, sphalerite, pyrite, puritite, and minor galena are the main mineral components of this massive sulfide. This boulder is around 1 ton and 20 meters south of 02&04. The values across 0.75 m are 1.98%Cu, 5.33%Zn, 45.2ppm Ag, 0.07%Pb

VMS-02. Laminated massive sulfide boulder that is a gray highly silicified unit. The mineral assemblage is the same as VMS-01 with some silica and less calchopyrite. The sample values across 0.5 m of -02 are 0.53%Cu, 5.62%Zn, and 38.4ppmAg, 0.65%Pb

VMS-03 Laminated massive sulfide boulder that is decaying and crumbling with some iron stain but not as much as VMS-01. The calcho is a little less than 01 but the mineral suite looks basically the same. Boulder is around 10 tons and 60 meters north of VMS-02 and -04 The value across 2 m of -03 is 0.53% Cu, 14.0%Zn, 39.4ppm Ag, 0.37%Pb

VMS-04 Laminated massive sulfide boulder that is highly silicified with all the sulfides mentioned in -01 but with a higher percentage of calchopyrite and minor silica. The boulder is around 2 tons and 3meters west of -02, 1 meter from the creek. The values across 0.5 m were 4.60%Cu, 4.00%Zn, and 41.5ppmAg, 0.05%Pb

RECOMMENDATIONS

From the values seen in the assays of the massive sulfide boulders and the geophysical anomalies, up ice from these boulders, drilling is recommended and planned for August of 2004. There needs to be geological work done with whole rock analysis and strike and dip measurements to tie in the observable geology with the geophysics. More geophysics needs to be done to cover all the possible down ice scenarios and see if any other conductors exist along strike. This should be done before the drill arrives so that the angle and orientation of the drilling is correct. If more conductors are seen, then they too can be drilled at this time. The Froberg showing needs trenching continued across the gabbro, sedimentary sequence, to get fresh exposure and grade, to determine where a drill target may exist. The compressor and drill are presently on site, so this can take place as soon as weather permits. The magnetometer would be useful for following the gabbro unit under the sedimentary rocks. More discussions need to be made to see if any geophysics can decipher between metallic conductors and graphitic ones, before the EM possibility is pursued, as a graphitic silt stone envelope surrounds the gabbroic, chert mineralization.

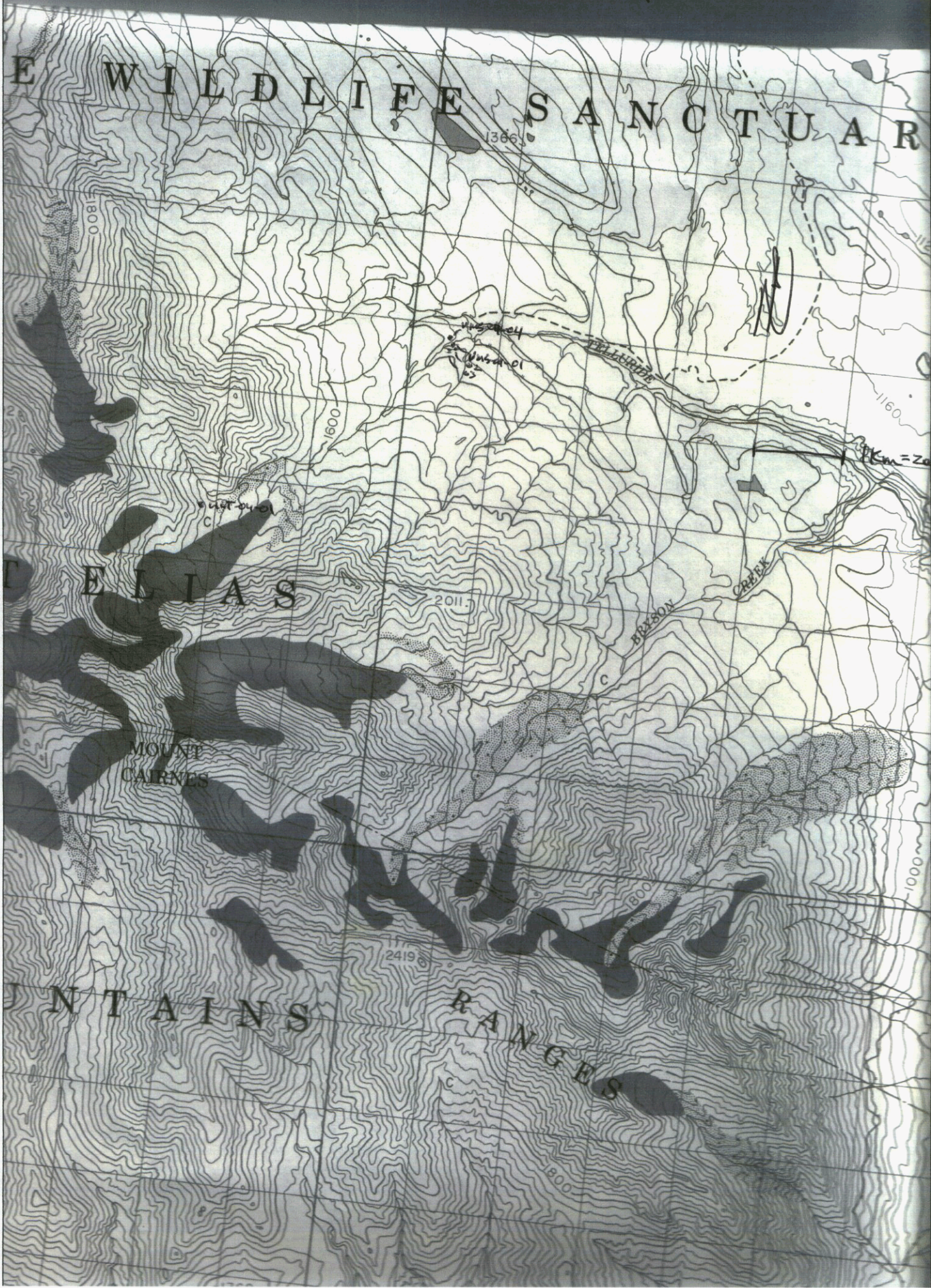

115-B-16

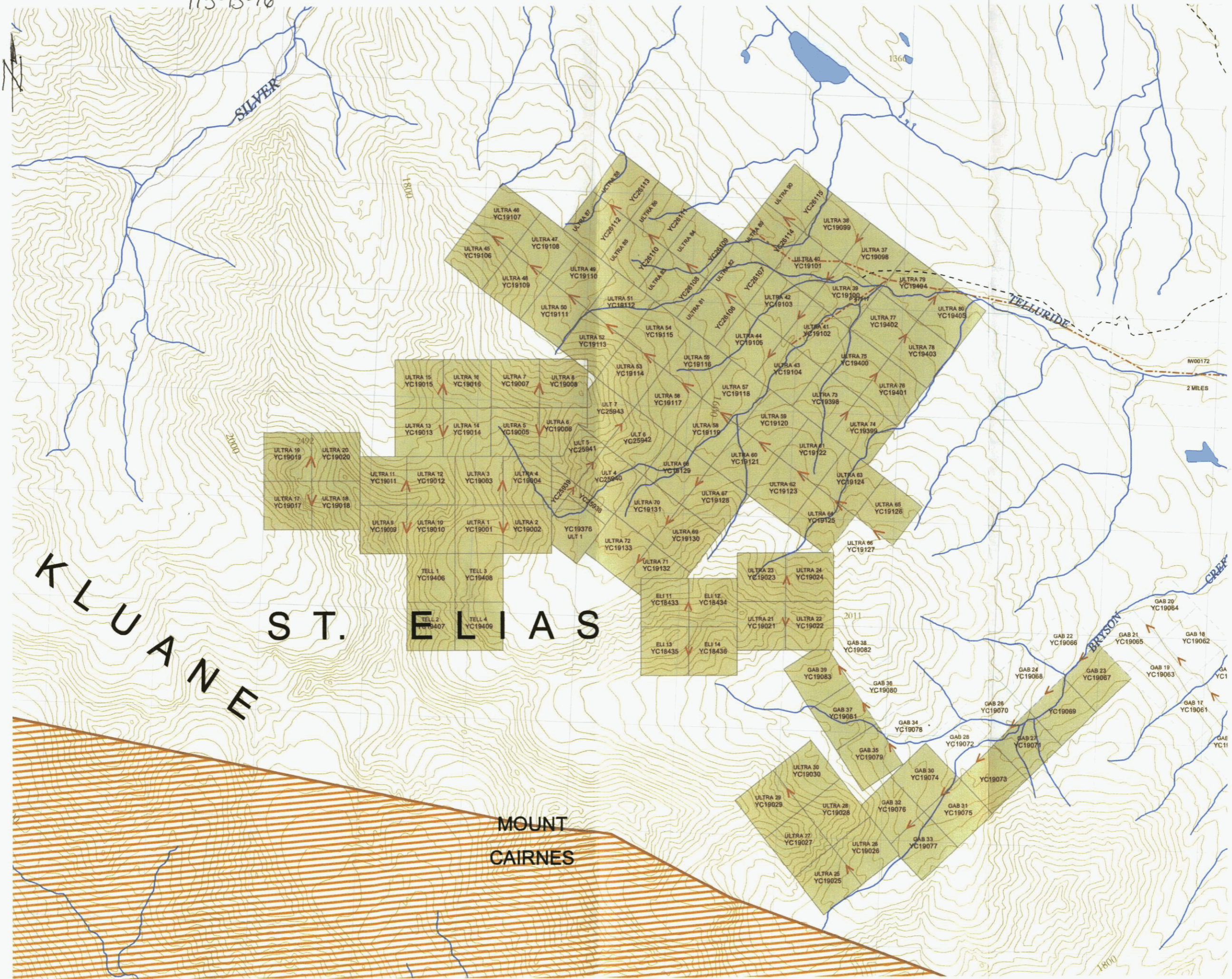

KLUANE ST. ELIAS

MOUNT CAIRNES

Statement of Expenditures on ULT 1

Darcy MacGillivray @ \$300/day x 13 days.....	\$ 3900.00
(hand trenching, pad building, packing gear in and out)	
Andrew Robinson @ \$300/day x 11 days.....	\$ 3300.00
Tom Morgan @ \$300/day x 13 days.....	\$ 3900.00
Report preparation.....	\$ 900.00
Truck rental @ \$390/wk x 1.5.....	\$ 585.00
Prospects North expediting.....	\$ 250.00
Explosives.....	\$ 892.60
Expeditables (sample bags, ect).....	\$ 87.36
Aurora rental of 4 wheeler and camp @ \$561.75/wk.....	\$ 561.75
Aurora report \$1819.00 x .5.....	\$ 909.50
Total.....	\$15286.21

Work was done on the following dates Sept. 21 to 25, Oct 14 to 15, & Oct. 25 to 30 doing hand work and packing gear to make a 20' x 15' x 5' pad for compressor and gear as well as a hand trench measuring 20' x 10' x 8' on Froberg showing.



ALS Chemex
EXCELLENCE IN ANALYTICAL CHEMISTRY
 ALS Canada Ltd
 212 Brooksbank Avenue
 North Vancouver BC V7J 2C1 Canada
 Phone: 604 984 0221 Fax: 604 984 0218

To: 19651 YUKON INC.
 BAG 7080
 DAWSON CITY YT Y0B 1G0

Page: 1
 Date: 27-JAN-2004
 Account: YUKON

PARTIAL DATA VA03054045

Project: Ultra
 P.O. No.:
 This report is for 5 Rock samples submitted to our lab in Vancouver, BC, Canada on 17-DEC-2003.
 The following have access to data associated with this certificate:
 DENNIS FONG TOM MORGAN

SAMPLE PREPARATION

ALS CODE	DESCRIPTION
WEI-21	Received Sample Weight
LOG-22	Sample login - Rod w/o BarCode
CRU-31	Fine crushing - 70% <2mm
SPL-21	Split sample - riffle splitter
PUL-31	Pulverize split to 85% <75 um

ANALYTICAL PROCEDURES

ALS CODE	DESCRIPTION	
PGM-MS26	PGE Nickel Sulfide Collection	
PGM-ICP23	Pt, Pd, Au 5g FA ICP	ICP-AES
PGM-ICP27	Ore grade Pt, Pd and Au by ICP	ICP-AES
Cu-AA62	Ore grade Cu - four acid / AAS	AAS
Ni-AA62	Ore grade Ni - four acid / AA	AAS
Zn-AA62	Ore grade Zn - four acid / AAS	AAS
ME-MS61	47 element four acid ICP-MS	

PARTIAL DATA REPORT

To: 19651 YUKON INC.
 ATTN: TOM MORGAN
 BAG 7080
 DAWSON CITY YT Y0B 1G0

This is a Partial Data Report for the analytical results of the above mentioned methods. A final Certificate of Analysis will be available upon completion of all requested methods.



ALS Chemex

EXCELLENCE IN ANALYTICAL CHEMISTRY

ALS Canada Ltd.

212 Brooksbank Avenue
 North Vancouver BC V7J 2C1 Canada
 Phone: 604 984 0221 Fax: 604 984 0218

To: 19651 YUKON INC.
 BAG 7080
 DAWSON CITY YT Y0B 1G0

Page: 2 - C
 Total # Pages: 2 (A - D)
 Date: 27-JAN-2004
 Account: YUKON

Project: Ultra

PARTIAL DATA REPORT VA03054045

Sample Description	Method Analyte Units LOR	ME-M961	ME-M961	ME-M961	ME-M961	ME-M961	ME-M961	ME-M961	ME-M961	ME-M961	ME-M961	ME-M961	ME-M961	ME-M961	ME-M961	
		Rb ppm	Re ppm	S %	Sb ppm	Se ppm	Sn ppm	Sr ppm	Ta ppm	Te ppm	Th ppm	Ti %	Tl ppm	Tl ppm	U ppm	V ppm
		0.1	0.002	0.01	0.05	1	0.2	0.2	0.05	0.05	0.2	0.01	0.02	0.1	1	0.1
VMS-04-01		7.3	0.004	>10	22.5	76	17.4	40.8	<0.05	1.65	0.4	0.08	6.91	0.4	60	1.2
VMS-04-02		2.4	0.004	>10	44.0	68	6.8	15.8	<0.05	1.48	<0.2	<0.01	16.30	0.2	50	1.1
VMS-04-03		2.9	0.007	>10	49.8	63	14.1	8.8	<0.05	2.45	<0.2	<0.01	16.70	0.1	44	0.8
VMS-04-04		4.9	0.011	>10	5.25	130	18.8	64.1	<0.05	2.25	<0.2	0.04	4.22	0.2	41	0.4
ULT-04-01		0.5	0.008	5.04	3.26	34	4.9	247	0.40	6.51	2.9	0.25	0.03	1.1	82	0.5

PARTIAL DATA REPORT

Comments: Highly mineralized samples may bias results for some elements.



ALS Chemex

EXCELLENCE IN ANALYTICAL CHEMISTRY

ALS Canada Ltd

212 Brooksbank Avenue
 North Vancouver BC V7J 2C1 Canada
 Phone: 604 984 0221 Fax: 604 984 0218

To: 19651 YUKON INC.
 BAG 7080
 DAWSON CITY YT Y0B 1G0

Page: 2 - A
 Total # Pages: 2 (A - D)
 Date: 27-JAN-2004
 Account: YUKON

Project: Ultra

PARTIAL DATA REPORT VA03054045

Sample Description	Method Analyte Units LOR	WEI-21	ME-M861	ME-M861	ME-M861	ME-M861	ME-M861	ME-M861	ME-M861	ME-M861	ME-M861	ME-M861	ME-M861	ME-M861	ME-M861	
		Recvd Wt kg	Ag ppm	Al %	As ppm	Ba ppm	Be ppm	Bi ppm	Ca %	Cd ppm	Ce ppm	Co ppm	Cr ppm	Cs ppm	Cu ppm	Fe %
		0.02	0.01	0.01	0.2	18	0.05	0.01	0.01	0.02	0.01	0.1	1	0.05	0.2	0.01
VMS-04-01		4.80	46.2	0.71	269	20	0.12	10.65	3.67	168.5	3.08	145.0	46	0.21	>10000	>25
VMS-04-02		3.98	38.4	0.13	630	10	<0.06	12.70	3.13	120.0	0.69	103.6	46	0.08	6260	>25
VMS-04-03		9.42	39.4	0.17	661	10	<0.06	2.98	0.82	276	0.74	24.6	23	0.09	6600	>25
VMS-04-04		3.14	41.6	0.61	160.6	20	0.20	15.80	6.61	89.2	3.64	293	4	0.20	>10000	>25
ULT-04-01		6.70	19.10	3.35	6.2	120	0.86	3.34	7.96	4.36	19.26	121.6	70	0.08	>10000	7.50

PARTIAL DATA REPORT

Comments: Highly mineralized samples may bias results for some elements.



ALS Chemex

EXCELLENCE IN ANALYTICAL CHEMISTRY

ALS Canada Ltd.

212 Brooksbank Avenue
 North Vancouver BC V7J 2C1 Canada
 Phone: 604 984 0221 Fax: 604 984 0218

To: 19651 YUKON INC.
 BAG 7080
 DAWSON CITY YT Y0B 1G0

Page: 2 - D
 Total # Pages: 2 (A - D)
 Date: 27-JAN-2004
 Account: YUKON

Project: Ultra

PARTIAL DATA REPORT VA03054045

Sample Description	Method	ME-M861	ME-M861	ME-M861	PGM-ICP27	PGM-ICP27	PGM-ICP27	Cu-AA62	NI-AA62	Zn-AA62
	Analyte	Y	Zn	Zr	Au	Pt	Pd	Cu	NI	Zn
Units		ppm	ppm	ppm	ppm	ppm	ppm	%	%	%
LOR		0.1	2	0.6	0.03	0.03	0.03	0.01	0.01	0.01
VMS-04-01		4.2	>10000	16.1				1.98		5.33
VMS-04-02		0.6	>10000	3.4				0.53		5.62
VMS-04-03		0.6	>10000	2.2				0.53		14.00
VMS-04-04		3.7	>10000	6.4				4.80		4.00
ULT-04-01		12.2	390	65.7	0.54	1.65	7.09	4.39	0.48	

PARTIAL DATA REPORT

Comments: Highly mineralized samples may bias results for some elements.



ALS Chemex

EXCELLENCE IN ANALYTICAL CHEMISTRY

ALS Canada Ltd.

212 Brooksbank Avenue
 North Vancouver BC V7J 2C1 Canada
 Phone: 604 984 0221 Fax: 604 984 0218

To: 19651 YUKON INC.
 BAG 7080
 DAWSON CITY YT Y0B 1G0

Page: 2 - B
 Total # Pages: 2 (A - D)
 Date: 27-JAN-2004
 Account: YUKON

Project: Ultra

PARTIAL DATA REPORT VA03054045

Sample Description	Method	ME-M961	ME-M961	ME-M961	ME-M961	ME-M961	ME-M961	ME-M961	ME-M961	ME-M961	ME-M961	ME-M961	ME-M961	ME-M961	ME-M961	
	Analyte	Ga	Ge	Hf	In	K	La	Li	Mg	Mn	Mo	Na	Nb	Ni	P	Pb
	Units	ppm	ppm	ppm	ppm	%	ppm	ppm	%	ppm	ppm	%	ppm	ppm	ppm	ppm
	LOR	0.05	0.05	0.1	0.005	0.01	0.6	0.2	0.01	5	0.05	0.01	0.1	0.2	10	0.5
VMS-04-01		12.05	0.61	0.4	2.80	0.22	1.6	3.9	0.11	489	22.7	0.15	0.8	49.4	90	651
VMS-04-02		10.15	0.56	<0.1	1.585	0.07	<0.5	1.2	0.02	508	25.3	<0.01	0.2	35.4	10	6480
VMS-04-03		22.7	0.55	<0.1	0.549	0.07	0.5	1.8	0.04	663	18.40	0.01	0.2	27.3	10	3660
VMS-04-04		9.34	0.84	0.2	3.25	0.15	1.8	3.1	0.13	593	14.50	0.10	0.4	47.4	10	548
ULT-04-01		8.16	0.36	2.4	0.348	0.02	12.8	4.0	1.32	290	2.62	1.42	7.2	4440	520	29.9

PARTIAL DATA REPORT

Comments: Highly mineralized samples may bias results for some elements.

Claim Status Report

25 May 2004

Claim Name and Nbr.	Grant No.	Expiry Date	Registered Owner	% Owned	NTS #'s
TELL 1 - 4	YC19406 - YC19409	2009/10/22	Tom Morgan	100.00	115B16
R ULT 1	YC19376	2017/09/14	Tom Morgan	100.00	115B16
R ULT 2 - 3	YC25938 - YC25939	2009/05/07	19651 Yukon Ltd.	100.00	115B16 F
R ULT 4	YC25940	2009/05/07	19651 Yukon Ltd.	100.00	115B16
R ULT 5	YC25941	2009/05/07	19651 Yukon Ltd.	100.00	115B16 F
R ULT 6	YC25942	2009/05/07	19651 Yukon Ltd.	100.00	115B16
R ULT 7	YC25943	2009/05/07	19651 Yukon Ltd.	100.00	115B16 F
P ULT 8 - 20	YC26359 - YC26371	2005/02/13	Tom Morgan	100.00	115B16
P ULT 21	YC26239	2005/02/11	Tom Morgan	100.00	115B16
P ULT 21	YC26372	2005/02/13	Tom Morgan	100.00	115B16
P ULT 22 - 140	YC26240 - YC26358	2005/02/11	Tom Morgan	100.00	115B16
P ULT 142 - 176	YC26373 - YC26407	2005/02/13	Tom Morgan	100.00	115B16
R ULTRA 1	YC19001	2010/12/07	Tom Morgan	100.00	115B16
R ULTRA 2	YC19002	2013/12/07	Tom Morgan	100.00	115B16
R ULTRA 3 - 5	YC19003 - YC19005	2010/12/07	Tom Morgan	100.00	115B16
R ULTRA 6	YC19006	2009/12/07	Tom Morgan	100.00	115B16
R ULTRA 7 - 11	YC19007 - YC19011	2007/12/07	Tom Morgan	100.00	115B16
R ULTRA 12 - 13	YC19012 - YC19013	2008/12/07	Tom Morgan	100.00	115B16
R ULTRA 14	YC19014	2010/12/07	Tom Morgan	100.00	115B16
R ULTRA 15 - 20	YC19015 - YC19020	2007/12/07	Tom Morgan	100.00	115B16
R ULTRA 21	YC19021	2006/12/07	Tom Morgan	100.00	115B16
R ULTRA 22	YC19022	2005/12/07	Tom Morgan	100.00	115B16
R ULTRA 23	YC19023	2007/12/07	Tom Morgan	100.00	115B16
R ULTRA 24 - 30	YC19024 - YC19030	2005/12/07	Tom Morgan	100.00	115B16
R ULTRA 37 - 40	YC19098 - YC19101	2012/02/12	Vern Matkovich	100.00	115B16
R ULTRA 41	YC19102	2010/02/12	Vern Matkovich	100.00	115B16
R ULTRA 42	YC19103	2012/02/12	Vern Matkovich	100.00	115B16
R ULTRA 43 - 44	YC19104 - YC19105	2010/02/12	Vern Matkovich	100.00	115B16
R ULTRA 45 - 52	YC19106 - YC19113	2006/02/12	Tom Morgan	100.00	115B16
R ULTRA 53 - 58	YC19114 - YC19119	2008/02/12	Tom Morgan	100.00	115B16
R ULTRA 59 - 65	YC19120 - YC19126	2006/02/12	Vern Matkovich	100.00	115B16
R ULTRA 67	YC19128	2006/02/12	Vern Matkovich	100.00	115B16
R ULTRA 68	YC19129	2008/02/12	Vern Matkovich	100.00	115B16
R ULTRA 69	YC19130	2006/02/12	Vern Matkovich	100.00	115B16
R ULTRA 70	YC19131	2008/02/12	Vern Matkovich	100.00	115B16
R ULTRA 71	YC19132	2006/02/12	Vern Matkovich	100.00	115B16

Total claims selected : 386

Left column indicator legend:

- R - Indicates the claim is on one or more pending renewal(s).
- P - Indicates the claim is pending.

Right column indicator legend:

- L - Indicates the Quartz Lease.
- F - Indicates Full Quartz fraction (25+ acres)
- P - Indicates Partial Quartz fraction (<25 acres)

- D - Indicates Placer Discovery
- C - Indicates Placer Codiscovery
- B - Indicates Placer Fraction

Claim Status Report

25 May 2004

Claim Name and Nbr.	Grant No.	Expiry Date	Registered Owner	% Owned	NTS #'s
R ULTRA 72	YC19133	2008/02/12	Vern Matkovich	100.00	115B16
ULTRA 73 - 80	YC19398 - YC19405	2011/10/22	Tom Morgan	100.00	115B16
ULTRA 81 - 90	YC26106 - YC26115	2004/12/08	Tom Morgan	100.00	115B16

Criteria(s) used for search:

CLAIM STATUS: ACTIVE & PENDING OWNER(S): 19651 YUKON LTD., MATKOVICH VERN, MORGAN TOM
REGULATION TYPE: QUARTZ

Left column indicator legend:

- R - Indicates the claim is on one or more pending renewal(s).
- P - Indicates the claim is pending.

Right column indicator legend:

- L - Indicates the Quartz Lease.
- F - Indicates Full Quartz fraction (25+ acres)
- P - Indicates Partial Quartz fraction (<25 acres)

Total claims selected : 386

- D - Indicates Placer Discovery
- C - Indicates Placer Codiscovery
- B - Indicates Placer Fraction

Claim Status Report

25 May 2004

Claim Name and Nbr.	Grant No.	Expiry Date	Registered Owner	% Owned	NTS #'s
AR 1 - 2	YC18359 - YC18360	2008/02/14	Tom Morgan	100.00	115G05
AR 3 - 6	YC18361 - YC18364	2005/02/14	Tom Morgan	100.00	115G05
AR 7 - 15	YC18365 - YC18373	2008/02/14	Tom Morgan	100.00	115G05
AR 16 - 17	YC18374 - YC18375	2006/02/14	Tom Morgan	100.00	115G05, 115G12
AR 18	YC18376	2005/02/14	Tom Morgan	100.00	115G12
AR 19	YC18377	2006/02/14	Tom Morgan	100.00	115G12
AR 20 - 22	YC18378 - YC18380	2005/02/14	Tom Morgan	100.00	115G12
AR 52	YC18410	2005/02/14	Tom Morgan	100.00	115G12
AR 54	YC18412	2005/02/14	Tom Morgan	100.00	115G12
AR 56	YC18414	2005/02/14	Tom Morgan	100.00	115G12
AR 61	YC18892	2008/09/20	Tom Morgan	100.00	115G05
R ELI 11	YC18433	2010/02/22	Tom Morgan	100.00	115B16
R ELI 12	YC18434	2011/02/22	Tom Morgan	100.00	115B16
R ELI 13	YC18435	2010/02/22	Tom Morgan	100.00	115B16
R ELI 14	YC18436	2012/02/22	Tom Morgan	100.00	115B16
R GAB 23	YC19067	2006/02/12	Tom Morgan	100.00	115B16
R GAB 25	YC19069	2006/02/12	Tom Morgan	100.00	115B16
R GAB 27	YC19071	2006/02/12	Tom Morgan	100.00	115B16
R GAB 29	YC19073	2006/02/12	Tom Morgan	100.00	115B16
R GAB 30 - 33	YC19074 - YC19077	2006/02/12	Vern Matkovich	100.00	115B16
R GAB 35	YC19079	2006/02/12	Vern Matkovich	100.00	115B16
R GAB 37	YC19081	2006/02/12	Vern Matkovich	100.00	115B16
R GAB 39	YC19083	2006/02/12	Vern Matkovich	100.00	115B16
GAB 40 - 43	YC19084 - YC19087	2005/02/12	Tom Morgan	100.00	115B16
GAB 44 - 47	YC19088 - YC19091	2005/02/12	Vern Matkovich	100.00	115B16
P JEN 1 - 4	YC26408 - YC26411	2005/02/13	Tom Morgan	100.00	115B16
P JEN 5 - 6	YC26412 - YC26413	2005/02/13	Tom Morgan	100.00	115B16 F
P JEN 7 - 10	YC26414 - YC26417	2005/02/13	Tom Morgan	100.00	115B16
P JEN 11 - 12	YC26418 - YC26419	2005/02/13	Tom Morgan	100.00	115B16 P
P JEN 13 - 15	YC26420 - YC26422	2005/02/13	Tom Morgan	100.00	115B16
P JEN 16 - 17	YC26423 - YC26424	2005/02/13	Tom Morgan	100.00	115B16 F
P JEN 18 - 40	YC26425 - YC26447	2005/02/13	Tom Morgan	100.00	115B16
P JEN 120	YC26448	2005/02/13	Tom Morgan	100.00	115B16
P JEN 136 - 167	YC26450 - YC26481	2005/02/13	Tom Morgan	100.00	115B16
P JEN 251	YC26449	2005/02/13	Tom Morgan	100.00	115B16

Total claims selected : 386

Left column indicator legend:

- R - Indicates the claim is on one or more pending renewal(s).
- P - Indicates the claim is pending.

Right column indicator legend:

- L - Indicates the Quartz Lease.
- F - Indicates Full Quartz fraction (25+ acres)
- P - Indicates Partial Quartz fraction (<25 acres)

- D - Indicates Placer Discovery
- C - Indicates Placer Codiscovery
- B - Indicates Placer Fraction

Claim Status Report

25 May 2004

Claim Name and Nbr.	Grant No.	Expiry Date	Registered Owner	% Owned	NTS:#s	
AR 1 - 2	YC18359 - YC18360	2008/02/14	Tom Morgan	100.00	115G05	
AR 3 - 6	YC18361 - YC18364	2005/02/14	Tom Morgan	100.00	115G05	
AR 7 - 15	YC18365 - YC18373	2008/02/14	Tom Morgan	100.00	115G05	
AR 16 - 17	YC18374 - YC18375	2006/02/14	Tom Morgan	100.00	115G05, 115G12	
AR 18	YC18376	2005/02/14	Tom Morgan	100.00	115G12	
AR 19	YC18377	2006/02/14	Tom Morgan	100.00	115G12	
AR 20 - 22	YC18378 - YC18380	2005/02/14	Tom Morgan	100.00	115G12	
AR 52	YC18410	2005/02/14	Tom Morgan	100.00	115G12	
AR 54	YC18412	2005/02/14	Tom Morgan	100.00	115G12	
AR 56	YC18414	2005/02/14	Tom Morgan	100.00	115G12	
AR 61	YC18892	2008/09/20	Tom Morgan	100.00	115G05	
R ELI 11	YC18433	2010/02/22	Tom Morgan	100.00	115B16	
R ELI 12	YC18434	2011/02/22	Tom Morgan	100.00	115B16	
R ELI 13	YC18435	2010/02/22	Tom Morgan	100.00	115B16	
R ELI 14	YC18436	2012/02/22	Tom Morgan	100.00	115B16	
R GAB 23	YC19067	2006/02/12	Tom Morgan	100.00	115B16	
R GAB 25	YC19069	2006/02/12	Tom Morgan	100.00	115B16	
R GAB 27	YC19071	2006/02/12	Tom Morgan	100.00	115B16	
R GAB 29	YC19073	2006/02/12	Tom Morgan	100.00	115B16	
R GAB 30 - 33	YC19074 - YC19077	2006/02/12	Vern Matkovich	100.00	115B16	
R GAB 35	YC19079	2006/02/12	Vern Matkovich	100.00	115B16	
R GAB 37	YC19081	2006/02/12	Vern Matkovich	100.00	115B16	
R GAB 39	YC19083	2006/02/12	Vern Matkovich	100.00	115B16	
GAB 40 - 43	YC19084 - YC19087	2005/02/12	Tom Morgan	100.00	115B16	
GAB 44 - 47	YC19088 - YC19091	2005/02/12	Vern Matkovich	100.00	115B16	
P JEN 1 - 4	YC26408 - YC26411	2005/02/13	Tom Morgan	100.00	115B16	
P JEN 5 - 6	YC26412 - YC26413	2005/02/13	Tom Morgan	100.00	115B16	F
P JEN 7 - 10	YC26414 - YC26417	2005/02/13	Tom Morgan	100.00	115B16	
P JEN 11 - 12	YC26418 - YC26419	2005/02/13	Tom Morgan	100.00	115B16	P
P JEN 13 - 15	YC26420 - YC26422	2005/02/13	Tom Morgan	100.00	115B16	
P JEN 16 - 17	YC26423 - YC26424	2005/02/13	Tom Morgan	100.00	115B16	F
P JEN 18 - 40	YC26425 - YC26447	2005/02/13	Tom Morgan	100.00	115B16	
P JEN 120	YC26448	2005/02/13	Tom Morgan	100.00	115B16	
P JEN 136 - 167	YC26450 - YC26481	2005/02/13	Tom Morgan	100.00	115B16	
P JEN 251	YC26449	2005/02/13	Tom Morgan	100.00	115B16	
TELL 1 - 4	YC19406 - YC19409	2009/10/22	Tom Morgan	100.00	115B16	
R ULT 1	YC19376	2017/09/14	Tom Morgan	100.00	115B16	

Total claims selected : 386

Left column indicator legend:

- R - Indicates the claim is on one or more pending renewal(s).
- P - Indicates the claim is pending.

Right column indicator legend:

- L - Indicates the Quartz Lease.
- F - Indicates Full Quartz fraction (25+ acres)
- P - Indicates Partial Quartz fraction (<25 acres)

- D - Indicates Placer Discovery
- C - Indicates Placer Codiscovery
- B - Indicates Placer Fraction



Claim Status Report

25 May 2004

Claim Name and Nbr.	Grant No.	Expiry Date	Registered Owner	% Owned	NTS #'s	
R ULT 2 - 3	YC25938 - YC25939	2009/05/07	19651 Yukon Ltd.	100.00	115B16	F
R ULT 4	YC25940	2009/05/07	19651 Yukon Ltd.	100.00	115B16	
R ULT 5	YC25941	2009/05/07	19651 Yukon Ltd.	100.00	115B16	F
R ULT 6	YC25942	2009/05/07	19651 Yukon Ltd.	100.00	115B16	
R ULT 7	YC25943	2009/05/07	19651 Yukon Ltd.	100.00	115B16	F
P ULT 8 - 20	YC26359 - YC26371	2005/02/13	Tom Morgan	100.00	115B16	
P ULT 21	YC26239	2005/02/11	Tom Morgan	100.00	115B16	
P ULT 21	YC26372	2005/02/13	Tom Morgan	100.00	115B16	
P ULT 22 - 140	YC26240 - YC26358	2005/02/11	Tom Morgan	100.00	115B16	
P ULT 142 - 176	YC26373 - YC26407	2005/02/13	Tom Morgan	100.00	115B16	
R ULTRA 1	YC19001	2010/12/07	Tom Morgan	100.00	115B16	
R ULTRA 2	YC19002	2013/12/07	Tom Morgan	100.00	115B16	
R ULTRA 3 - 5	YC19003 - YC19005	2010/12/07	Tom Morgan	100.00	115B16	
R ULTRA 6	YC19006	2009/12/07	Tom Morgan	100.00	115B16	
R ULTRA 7 - 11	YC19007 - YC19011	2007/12/07	Tom Morgan	100.00	115B16	
R ULTRA 12 - 13	YC19012 - YC19013	2008/12/07	Tom Morgan	100.00	115B16	
R ULTRA 14	YC19014	2010/12/07	Tom Morgan	100.00	115B16	
R ULTRA 15 - 20	YC19015 - YC19020	2007/12/07	Tom Morgan	100.00	115B16	
R ULTRA 21	YC19021	2006/12/07	Tom Morgan	100.00	115B16	
R ULTRA 22	YC19022	2005/12/07	Tom Morgan	100.00	115B16	
R ULTRA 23	YC19023	2007/12/07	Tom Morgan	100.00	115B16	
R ULTRA 24 - 30	YC19024 - YC19030	2005/12/07	Tom Morgan	100.00	115B16	
R ULTRA 37 - 40	YC19098 - YC19101	2012/02/12	Vern Matkovich	100.00	115B16	
R ULTRA 41	YC19102	2010/02/12	Vern Matkovich	100.00	115B16	
R ULTRA 42	YC19103	2012/02/12	Vern Matkovich	100.00	115B16	
R ULTRA 43 - 44	YC19104 - YC19105	2010/02/12	Vern Matkovich	100.00	115B16	
R ULTRA 45 - 52	YC19106 - YC19113	2006/02/12	Tom Morgan	100.00	115B16	
R ULTRA 53 - 58	YC19114 - YC19119	2008/02/12	Tom Morgan	100.00	115B16	
R ULTRA 59 - 65	YC19120 - YC19126	2006/02/12	Vern Matkovich	100.00	115B16	
R ULTRA 67	YC19128	2006/02/12	Vern Matkovich	100.00	115B16	
R ULTRA 68	YC19129	2008/02/12	Vern Matkovich	100.00	115B16	
R ULTRA 69	YC19130	2006/02/12	Vern Matkovich	100.00	115B16	
R ULTRA 70	YC19131	2008/02/12	Vern Matkovich	100.00	115B16	
R ULTRA 71	YC19132	2006/02/12	Vern Matkovich	100.00	115B16	
R ULTRA 72	YC19133	2008/02/12	Vern Matkovich	100.00	115B16	
ULTRA 73 - 80	YC19398 - YC19405	2011/10/22	Tom Morgan	100.00	115B16	

Total claims selected : 386

Left column indicator legend:

- R - Indicates the claim is on one or more pending renewal(s).
- P - Indicates the claim is pending.

Right column indicator legend:

- L - Indicates the Quartz Lease.
- F - Indicates Full Quartz fraction (25+ acres)
- P - Indicates Partial Quartz fraction (<25 acres)

- D - Indicates Placer Discovery
- C - Indicates Placer Codiscovery
- B - Indicates Placer Fraction

Claim Status Report

25 May 2004

Claim Name and Nbr.	Grant No.	Expiry Date	Registered Owner	% Owned	NTS #'s
ULTRA 81 - 90	YC26106 - YC26115	2004/12/08	Tom Morgan	100.00	115B16

Criteria(s) used for search:

CLAIM STATUS: ACTIVE & PENDING OWNER(S): 19651 YUKON LTD., MATKOVICH VERN, MORGAN TOM
REGULATION TYPE: QUARTZ

Total claims selected : 386

Left column indicator legend:

- R - Indicates the claim is on one or more pending renewal(s).
- P - Indicates the claim is pending.

Right column indicator legend:

- L - Indicates the Quartz Lease.
- F - Indicates Full Quartz fraction (25+ acres)
- P - Indicates Partial Quartz fraction (<25 acres)

- D - Indicates Placer Discovery
- C - Indicates Placer Codiscovery
- B - Indicates Placer Fraction

Qualifications

The principles of 19651 Yukon Inc. are V. Matkovich and T. Morgan.

V. Matkovich has been actively prospecting in the Yukon since 1987. He prospected in the Carmacks area in 1987-1990, and made two trips to Apex Creek, Hayes Creek and Klimes Gulch near Prospector Mtn. During this time. In 1990 he completed the Basic Prospecting Course offered by the Yukon Chamber of Mines. In 1991 he moved to the Dawson District and established himself on Montana Creek in the Indian River area. From 1992-1995 he drilled and shafted extensively for placer gold on Montana Creek. At this time V. Matkovich and T. Morgan began working together on developing the Montana Creek placer, as well as exploring other creeks in the area for potential placers. These explorations involved the use of auger drills and shafts steam thawed to bedrock. Since 1995 V. Matkovich has been involved with T. Morgan on quartz hardrock exploration in the Indian River, Reindeer Mtn. and Haines Junction areas. Exploration in these areas is ongoing.

T. Morgan has been actively involved in prospecting since the summer of 1981 when he worked for Shell Minerals as a prospectors assistant. In 1983 he moved to the Yukon and worked with placer miners in ground evaluation and testing in the Sixty Mile, Carmacks, Dawson and Kluane areas. In the winter of 1984 he was in southern California prospecting in the Old Woman Mtns., the Panament Range and Inyo Range for hardrock gold. Some highly mineralized areas were discovered at this time in this rugged mountainous country. He worked underground at Miller Creek in the Sixty Mile area in 1985 and 1987 for Klondike Underground, testing and recording the Au values and gravel characteristics. He staked his own ground on Montana Creek in the Dawson District and Iron Creek in the Whitehorse District during this time Iron Creek was sold to an American outfit and Montana Creek was optioned to Rivest Bros. In 1987-88 he prospected with Glen Harris, Bill Harris, Ron Stack and Graham Davidson in the Kluane Range and in the Carmacks area around Mtn. Freegold. He worked with Doron Explorations on Caribou Creek and Lodestar Explorations in the Wheaton River area on Sb, Ag, and Au deposits in 1988-89. He worked on Montana Creek placer ground in 1990, and with Hughs-Lang Group prospecting in the Ogilvie Mtns. for bedded zinc, Thistle Creek for Au veins and placer shafting on upper Hunker Creek. From 1991-1994 he was involved in placer mining and testing on Montana Creek, where Tom Morgan and Vern Matkovich started working together. Stuart Schmidt optioned the upper Montana Creek and Vern Matkovich drilled for Schmidt. V. Matkovich optioned the ground below S. Schmidt and drilling was done there as well. In 1995 T. Morgan, Glen and Bill Harris and S. Schmidt drove a drift on Caribou Creek, with V. Matkovich and Eric Stoll, and intersected high grade gold in an epithermal vein deposit from Doron Explorations 1989 drill hole. In 1996 he worked in the Hess River area with B. Lueck (Yukon Gold Corp.), prospected for and found Fort Knox Style, Tombstone Suite intrusive hosting high grade Au, Bi veins. In 1997 he went with B. Lueck to Tok, Alaska and staked the Taurus Property, a Cu, Mo, Au porphyry. The same year T. Morgan and B. Lueck went to the Phillipines to prospect Au vein deposits, Cu-Mo porphyrys, Au hot spring deposits and massive Cu, Au sulfide veins. Work continued until 1999, finishing with drilling on the Plata Claims' Au, Pb, Zn vein at Fido Creek, in the Hess River country. With V. Matkovich, S. Schmidt and K. Jonas he staked the Bear Claims on Thistle Creek on a Pogo style deposit in 1999, along with the Wolf Claims on Scroggie Creek. He also organized and staked two Cu, Ni PGE targets in the Kluane Mafic Ultramafic Belt. Work is ongoing on these projects.

AURORA GEOSCIENCES LTD.

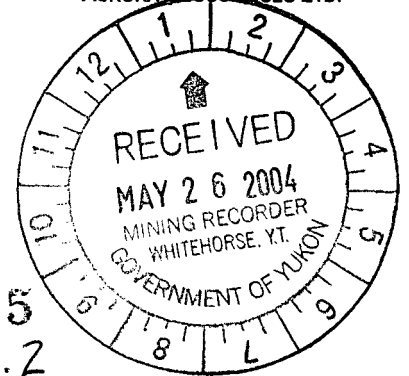

094465
V.2

TOM MORGAN

**HORIZONTAL LOOP ELECTROMAGNETIC,
SURVEY EXTENSIONS ON THE ULTRA PROPERTY,
HAINES JUNCTION AREA, YUKON TERRITORY**

Phil Jackson, B.Sc., P.Geoph.

Location: 60° 54' N 138° 15' W
NTS: 115 B/16
Mining District: Whitehorse
Date: December 17, 2003

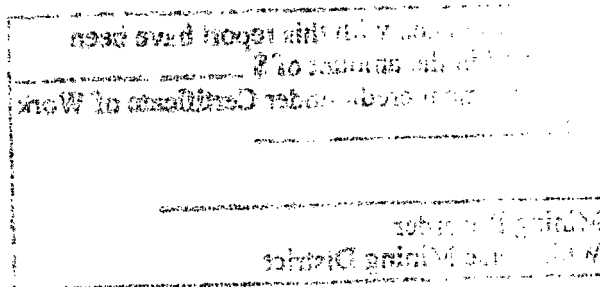

**YUKON ENERGY, MINES
& RESOURCES LIBRARY**
P.O. Box 2753
Whitehorse, Yukon Y1A 2C8

Costs associated with this report have been
approved in the amount of \$ 6,700.00
for assessment credit under Certificate of Work
No. QU27654
J. Sautter
Mining Recorder
Whitehorse Mining District

SUMMARY

This report describes a horizontal loop electromagnetic (HLEM) survey extension conducted on the Ultra Property by Aurora Geosciences Ltd. The property is in the Whitehorse Mining District, Yukon Territory and owned by Tom Morgan. The survey was conducted to investigate and define the southern extent of the UL-2 conductor, which was initially discovered in the 2002 geophysical program.

The HLEM survey extension was conducted from October 18 to October 24 on a previously established and cut grid. The program was run out of a camp established approximately 3 km east of the property along an access road leading to the property.

A 200 m coil separation was used for the HLEM survey to allow for deep penetration due to significant overburden/till cover. Line separation for the survey was 100 m and a station separation of 25 m. The 220, 880, 3520 and 7040 Hz frequencies were measured for the survey.

The 2002 HLEM survey carried out by Casselman (2003) identified two north trending conductors on the southern part of the grid. The western most conductor, UL-1, is a poorly conductive tabular conductor, which appears to be 60 to 80 m wide, is steeply east dipping and has a depth to top of 30 to 60 m. The width of the target and the poor conductance suggests that it is likely a weakly conductive rock unit rather than massive sulphide mineralization. The conductor is open to the south and does not appear to be intimately associated with any magnetic bedrock sources.

The eastern most conductor, UL-2, appears to be located at the base of a magnetically susceptible, east dipping rock unit. It has a conductance at the lower limit of what would normally be expected for a massive sulphide body. The source conductor is thin (<12.5 m) and subcrops at a depth of 60 to 80 m. The conductor is open to the south and north.

The HLEM survey extension did not locate any new conductive areas on the Ultra Grid. The 2003 HLEM survey extension are largely inconclusive due to the short line lengths relative to the coil spacing and the noise associated with the data. While the HLEM extension does not allow for new interpretations, the conclusions and recommendations made by Casselman (2003) still apply.

Recommendations made by Casselman (2003) are as follows. Extend the HLEM and magnetic surveys to the northeast to trace the extent of conductor UL-2 and to test the conductor to identify its' source by drilling. A geological mapping program of the area, especially in the Telluride creek valley where there is a fair amount of outcrop, may help to determine the orientation of geological features and assist in determining drilling orientations.

TABLE OF CONTENTS

1.0 INTRODUCTION 1

2.0 LOCATION AND ACCESS 1

3.0 REGIONAL GEOLOGY 3

4.0 GRID 3

5.0 PERSONNEL AND EQUIPMENT 5

6.0 SURVEY SPECIFICATIONS 5

7.0 DATA 6

8.0 HLEM THEORY AND INTERPRETATION PROCEDURES 6

9.0 RESULTS 12

10.0 CONCLUSIONS 13

11.0 RECOMMENDATIONS 14

12.0 REFERENCES 15

APPENDIX A STATEMENT OF QUALIFICATIONS 16

APPENDIX B SURVEY LOG 18

APPENDIX C FIELD MAPS 20

LIST OF FIGURES

Figure 1 - Property Location 2

Figure 2 - Claim Location Map 4

Figure MM1 8

Figure MM2. 9

Figure MM3. 10

Figure MM4. 11

1.0 INTRODUCTION

This report describes a horizontal loop electromagnetic (HLEM) survey extension conducted on the Ultra Property by Aurora Geosciences Ltd. The property is in the Whitehorse Mining District, Yukon Territory and owned by Tom Morgan. The survey was conducted to investigate and define the southern extent of the UL-2 conductor, which was initially discovered in the 2002 geophysical program.

The HLEM survey extension was conducted from October 18 to October 24 on a previously established and cut grid. The program was run out of a camp established approximately 3 km east of the property along an access road leading to the property.

2.0 LOCATION AND ACCESS

The Ultra Property is located on Telluride Creek, 42 km northwest of Haines Junction, on NTS map sheet 115 B/16. It is in the Whitehorse Mining District and is centered at approximately 60° 54' N, 138° 15' W (Figure 1). The property is 10 km west of the Alaska Highway and is accessible by a rough gravel road, which intersects the highway near Boutellier Summit.

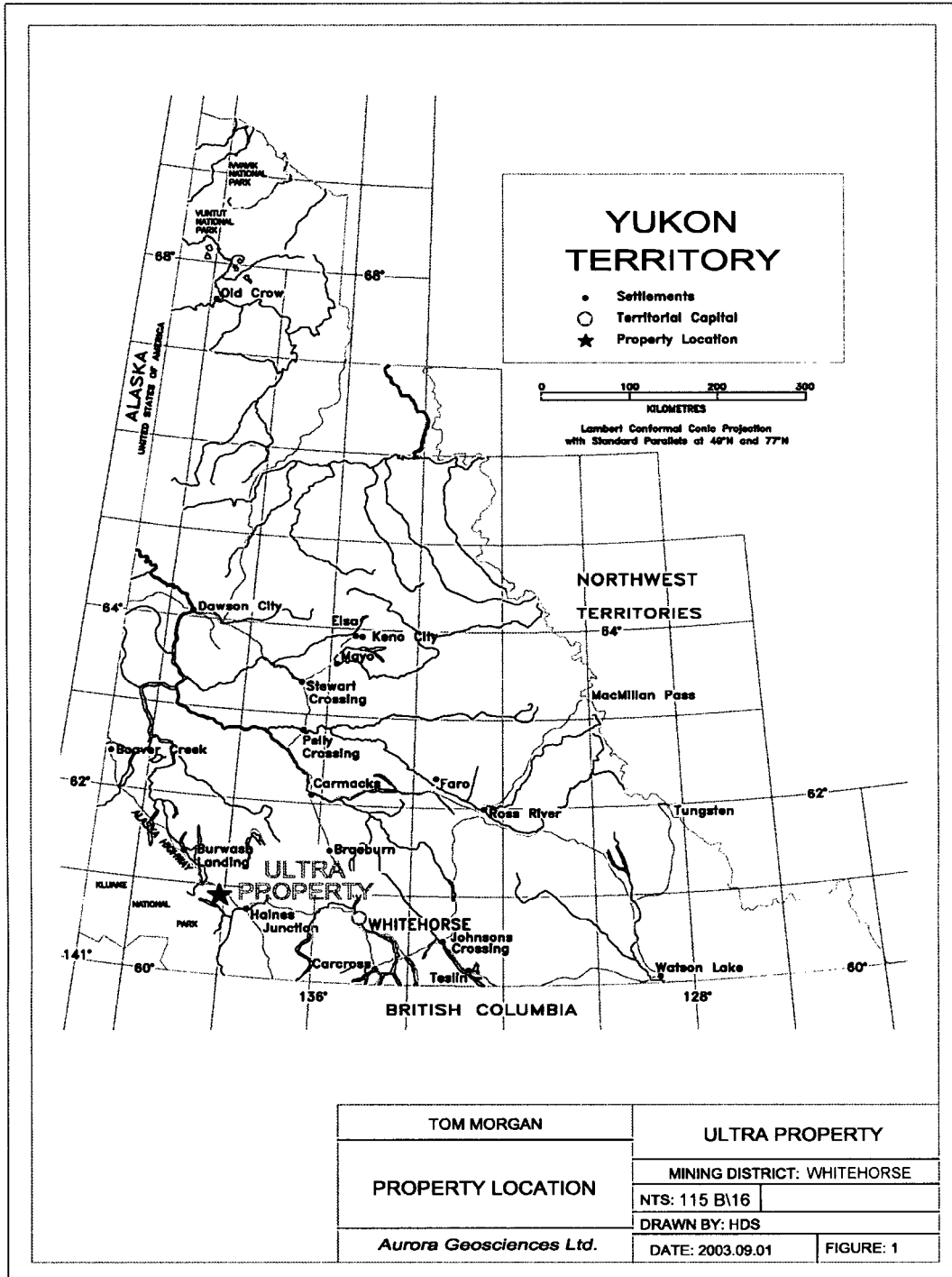

Figure 1 - Property Location

3.0 REGIONAL GEOLOGY

The Ultra Property occurs in the Insular Super Terrane, which is divided into Alexander Terrane, to the west and Wrangell Terrane to the east. In the region, Alexander Terrane is comprised of Silurian to Devonian Bullion Suite massive, well-bedded, light gray limestone or marble, argillite and phyllite. These are overlain by Devonian to Upper Triassic Icefield Group limestone, argillite, calcareous siltstone-sandstone and creamy-white gypsum and anhydrite. These rocks are intruded by the Devonian Steel Creek Suite, which is comprised of massive, medium- to coarse-grained, rusty green-green hornblende pyroxene gabbro sills and dykes with rare pods of peridotite (Gordey, 1999).

The Wrangell Terrane is comprised of Upper Triassic Chitison Group thin-bedded, light to dark gray limestone, dark gray argillite and white to creamy-white anhydrite. These rocks are overlain and in places interbedded with Upper Triassic Nicolai Group amygdaloidal basaltic and andesitic flows with local tuff, breccia, shale and thin-bedded bioclastic limestone. Both of these units are intruded by late Triassic Kluane Ultramafic Suite intrusions. The Kluane Ultramafic Suite is comprised of medium green-green, massive, medium-grained, pyroxene gabbro and dark-green to black peridotite and rare dunite. The Kluane Ultramafic Suite intrusives may be the source for the Nicolai Group volcanic rocks. These rocks are overlain by Upper Jurassic to Lower Cretaceous Dezadeash Group clastic sediments, by Paleocene to Oligocene Amphitheatre Group sediments and by Miocene to Pliocene Wrangell Lavas. The Dezadeash Group consists of a succession of dark buff-gray lithic greywacke, sandstone, siltstone, shale, argillite, phyllite and conglomerate. The Amphitheatre Group consists of yellow-buff sandstone, pebbly sandstone, polymictic conglomerate, siltstone, mudstone, minor carbonaceous shale and thin lignite coal. The Wrangell Lavas consist of rusty, red-brown basaltic andesite flows, interbedded with felsic tuff. All of these rocks are in turn overlain by Quaternary unconsolidated glacial, glaciofluvial and glaciolacustrine deposits.

The Kluane Ultramafic Suite hosts a number of magmatic nickel-copper-platinum group mineral occurrences in Wrangell Terrane from Northern BC, through Yukon and into Alaska. One of these occurrences, the Wellgreen Deposit, produced 200,000 tonnes of Ni-Cu-PGE ore in 1972 and 1973.

4.0 GRID

The location of the survey grid relative to the boundaries of the property is shown in Figure 2. Survey lines were cut by axe and marked by hip-chained (not slope corrected) with a line spacing of 100 m and station spacing of 25 m. Stations were marked with half-length, tagged survey lathe. A total of 2.725 line-km were covered by the HLEM survey extension.

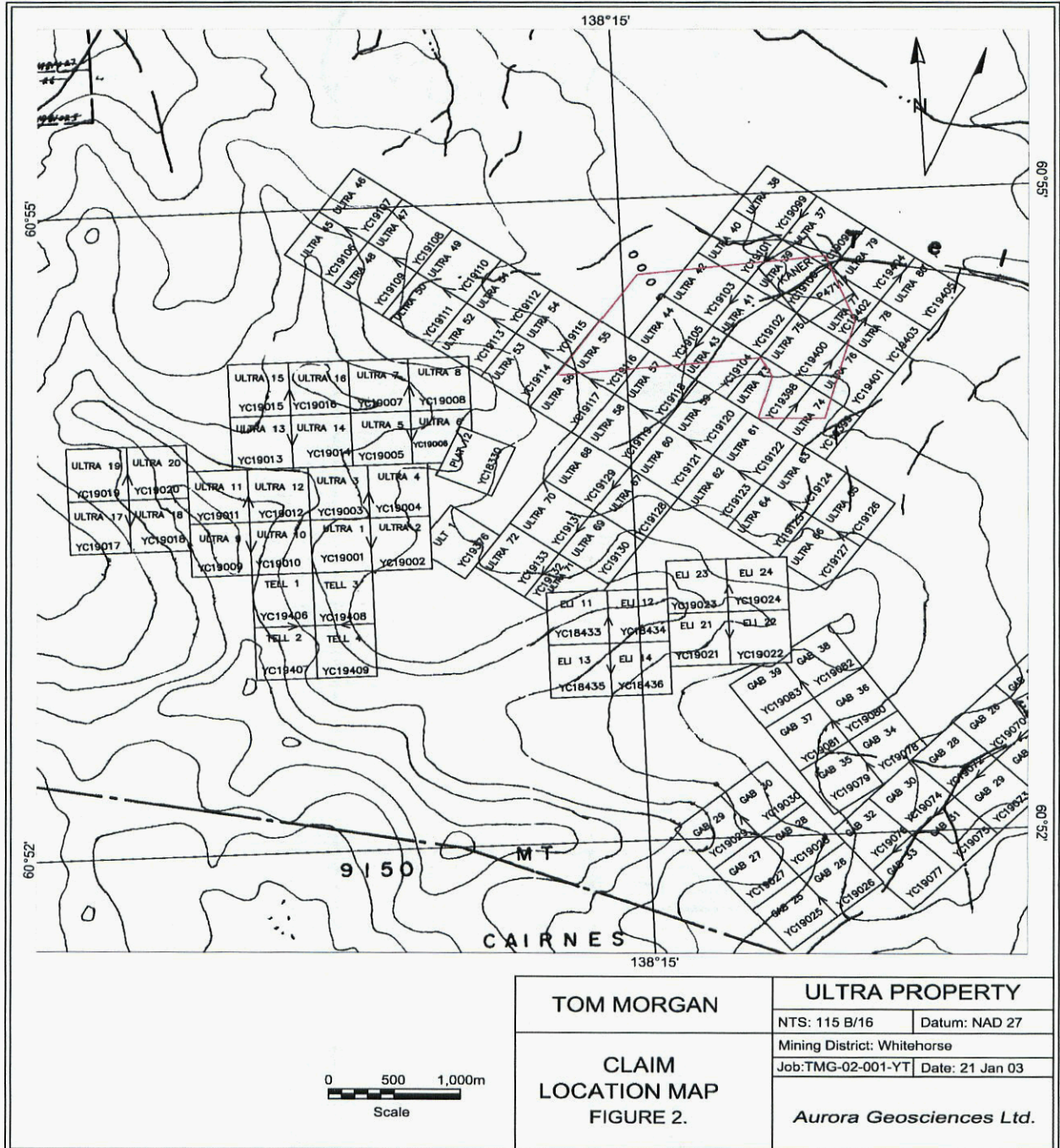

Figure 2 - Claim Location Map

5.0 PERSONNEL AND EQUIPMENT

A two-man HLEM crew consisting of Ron Joly and Tom Morgan conducted the surveys. They were equipped with the following instruments and equipment:

<u>Instruments:</u>	Apex Parametrics MaxMin I-10 and MaxMin Computer (MMC) equipped with 200 m cable.
<u>Data processing:</u>	P-100 laptop computer.
<u>Other equipment:</u>	Garmin 76 GPS and portable satellite phone.

The crew spent a total of 6 days on the Property. The survey log is attached as Appendix A.

6.0 SURVEY SPECIFICATIONS

The HLEM surveys were conducted according to the following specifications:

<u>Coil spacing:</u>	200 m
<u>Station spacing:</u>	25 m
<u>Frequencies:</u>	220 Hz, 880 Hz, 3520 Hz and 7040 Hz
<u>Terrain corrections:</u>	Slope chain method using oriented coils (i.e. tilt corrected in the field). Short coil errors introduced by irregular topography were removed during data processing.

The HLEM method requires that the coils be held a constant distance apart and be coplanar. In steep irregular terrain, the coils will frequently be less than the nominal coil spacing (short coiling) and may not be coplanar. These variations in coil geometry produce strong in-phase errors and must be removed from the data before plotting and interpretation. The method used to mitigate these effects requires a slope chained grid and requires the operator to measure the station-to-station terrain slope in percent with a clinometer. This is normally done by the receiver operator who was in the lead position on the surveys. The correct slope required to maintain the coils coplanar is the arithmetic average of the station-to-station slopes in the interval between the two coils. The operators hold the coils coplanar during the surveys by holding their coils at this orientation, which is calculated and displayed for each reading station by the Maxmin MMC. The effect of short coiling created by irregular topography was removed with Apex Parametrics data processing software (MMCFIX1). The numerical method is described in Varre (1990)(pp AII-3-4).

7.0 DATA

Data is appended to this report in digital format as ASCII XYZ files. Each file has a header on the first line showing the data contained in the columns beneath, where xxxIP AND xxxQ denotes the in-phase and quadrature components at the prefixing frequency in percent of the vertical primary field (Hz). The HLEM data format is:

```
Line Station UTM_Easting UTM_Northing 220IP 220Q 880IP 880Q 3520IP 3520Q ...
```

HLEM data is displayed in stacked profile plots showing the survey grid and the in-phase and quadrature readings as solid and dashed line profiles, respectively. The zero level on each profile is coincident with the survey line and the direction of the positive response is northward. A scale of 20% H_z per cm was used in the plotting. The locations of the grid lines have been registered to UTM coordinates with the best data available at the time of writing and UTM registration marks are shown on both HLEM and magnetic field plots. Along the grid lines, the small tick marks show the station locations and every 100 m is indicated by a larger tick. The north arrow in each plot indicates UTM (NAD 27) grid north. Conductors of interest are indicated with symbols at each intersection. All anomalies were interpreted as thin tabular conductors unless otherwise indicated. The circles indicating an anomaly are filled where required to indicate the calculated target conductance. Calculated depth to the top of the conductor and any excess width in the response, which might indicate a wide target are shown numerically on opposite sides of the anomaly symbols. Thick blue lines indicate conductor axes formed by linking similar line-to-line responses. The HLEM data was of generally average to poor quality with ambient noise levels attributable to coil geometry errors of 2-3% (220 Hz). At higher frequencies, some noise possibly caused by surficial geology is present. This has an amplitude of 3-5% at the highest frequencies.

8.0 HLEM THEORY AND INTERPRETATION PROCEDURES

The horizontal loop EM method is well described in standard texts such as Telford *et. al.* (1990) and Ketola and Puranen (1967). This section summarizes the key features of the HLEM method and describes the interpretation algorithms used in this survey program.

The HLEM method involves the use of a pair of separated horizontal coils. Most commonly, the surveys are conducted in the frequency domain. In this method, a sine wave of variable frequency is sent through one of the coils to create a time-varying vertical magnetic dipole source. The second coil is a receiver, which detects both the primary signal from the transmitting coil and a secondary signal created by magnetic induction in a conductive target in the earth. There are two variants of the method in the frequency domain, Slingram or conventional HLEM method and the Genie method.

The Slingram method (normally referred to as HLEM) requires that a sample of the transmitted signal be sent along a wire to the receiver where it is used to synchronize the phase of the receiver with the transmitter. This permits the receiver to remove the effect of the transmitter signal (primary field) and to split the remaining secondary field into two components. One component represents the portion of the secondary field, which is synchronized or in-phase with the primary field (in-phase component). The second component is the portion of the secondary field, which lags the primary field by one-quarter cycle (90°) (quadrature component). The ratio of the in-phase

to quadrature components is used to determine the electrical conductance of a target.

HLEM instruments remove the primary field from the signal to leave only the secondary field. By convention, a secondary field in the same direction as the primary field is recorded as positive while a secondary field in the opposite direction to the primary field is recorded as negative. HLEM data is commonly plotted as profiles with the reading plotted at the midpoint between the transmitter and receiver. The reason for this is that the response from a steeply dipping conductor, the most common target of this method, is strongest when the two coils straddle the conductor. Normally, the in-phase response is plotted as a solid line and the quadrature response as a dashed line.

The HLEM response of a flat lying body is shown in Figure MM2(a). Magnetic field lines (flux) are directed primarily into the region beneath the transmitter loop. Lenz's Law dictates that the induced secondary field will oppose the primary field. Consequently, at the receiver, both the primary and secondary field will be in the same direction. As a result, the response from a flat lying conductor consists of a positive response over the target. At the edge of the conductor, there is a negative response, which occurs when both coils are straddling the edge of the conductor. When the transmitter or receiver coil is over the edge of the conductor, there is no secondary field and the response is zero. As the depth to the flat lying conductor increases, the strength of the response is attenuated. The effective depth of investigation of the HLEM method for flat lying conductors is approximately 1.5 times the coil spacing.

The HLEM response of a steeply dipping conductor is shown in Figure MM2(b). Field lines from the transmitter are horizontal at a point midway between the two coils and in this orientation, cut the conductor at right angles creating the best coupling. Lenz's Law dictates that the secondary field will oppose the primary field and at the receiver coil, the secondary field is in the opposite direction to the primary field. As a result, the response when profiling over a steeply dipping conductor consists of a trough with peak negative value occurring when the coils straddle the conductor. The flanking positive peaks result from induction effects as the pair of coils are close to but not straddling the conductor. When either of the coils is directly over the target, the response is zero because the primary field is not well coupled with the target (i.e. it is perpendicular to the edge of the conductor) and little secondary field is created.

A dipping tabular conductor can be specified by the dip and dip direction, depth to top, target width and electrical conductance (conductivity thickness product or σt). The effect of varying these parameters is shown in Figure MM3 for the case of a response from a single isolated HLEM conductor. Asymmetry in the positive shoulders indicates the dip direction and the ratio of the positive shoulder responses can be used to estimate the dip (Figure MM3(a)). The depth to the top of the conductor largely determines the strength of the response. Increasing the depth to the top of the conductor decreases the amplitude of the response but does not otherwise change the shape of the response (Figure MM3(b)). The effective depth of investigation of the HLEM method for steeply dipping targets is approximately one half the coil spacing. If the conductor is wide, the location of the zero crossovers, normally equal to the coil spacing, will increase. If the width reaches approximately one half the coil spacing, the trough of the response for shallow targets will start to deflect slightly to the positive. If the width of the target approaches that of the coil spacing, the positive return in the trough will be apparent at any depth to target (Figure MM3(c)). As noted above, the electrical conductance controls the ratio of the in-phase to quadrature response. Weak targets show only a quadrature response. As the target conductance increases the strength of the in-phase component will increase. Very high conductance targets are characterized by strong in-phase responses and weak to very weak quadrature responses (Figure MM3(d)).

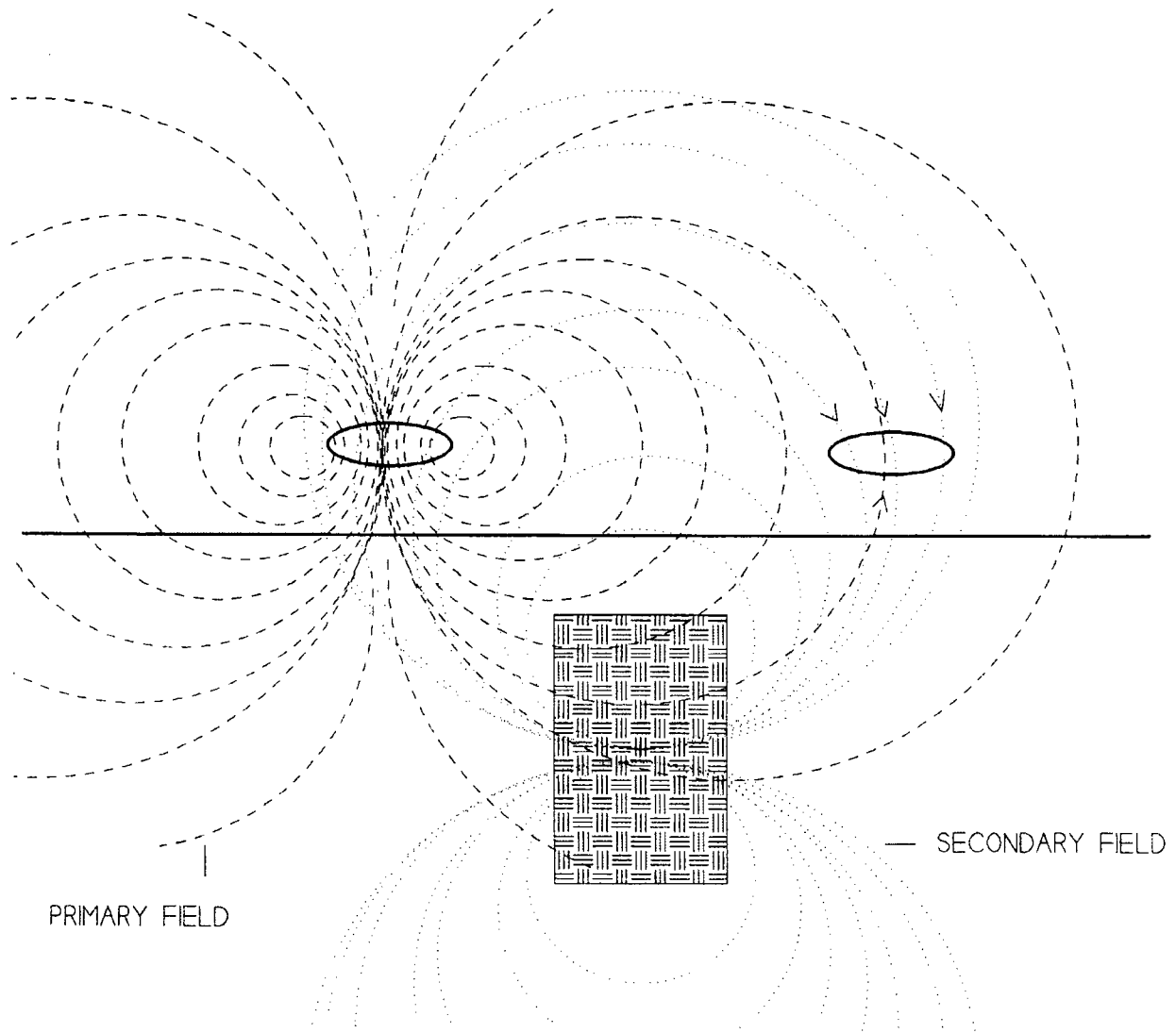

Figure MM1 - HLEM source field. The field from the transmitter loop produces an oscillating vertical magnetic dipole. This induces a secondary field in a conductive body in the earth. At the receiver coil, both the primary field and secondary field are received.

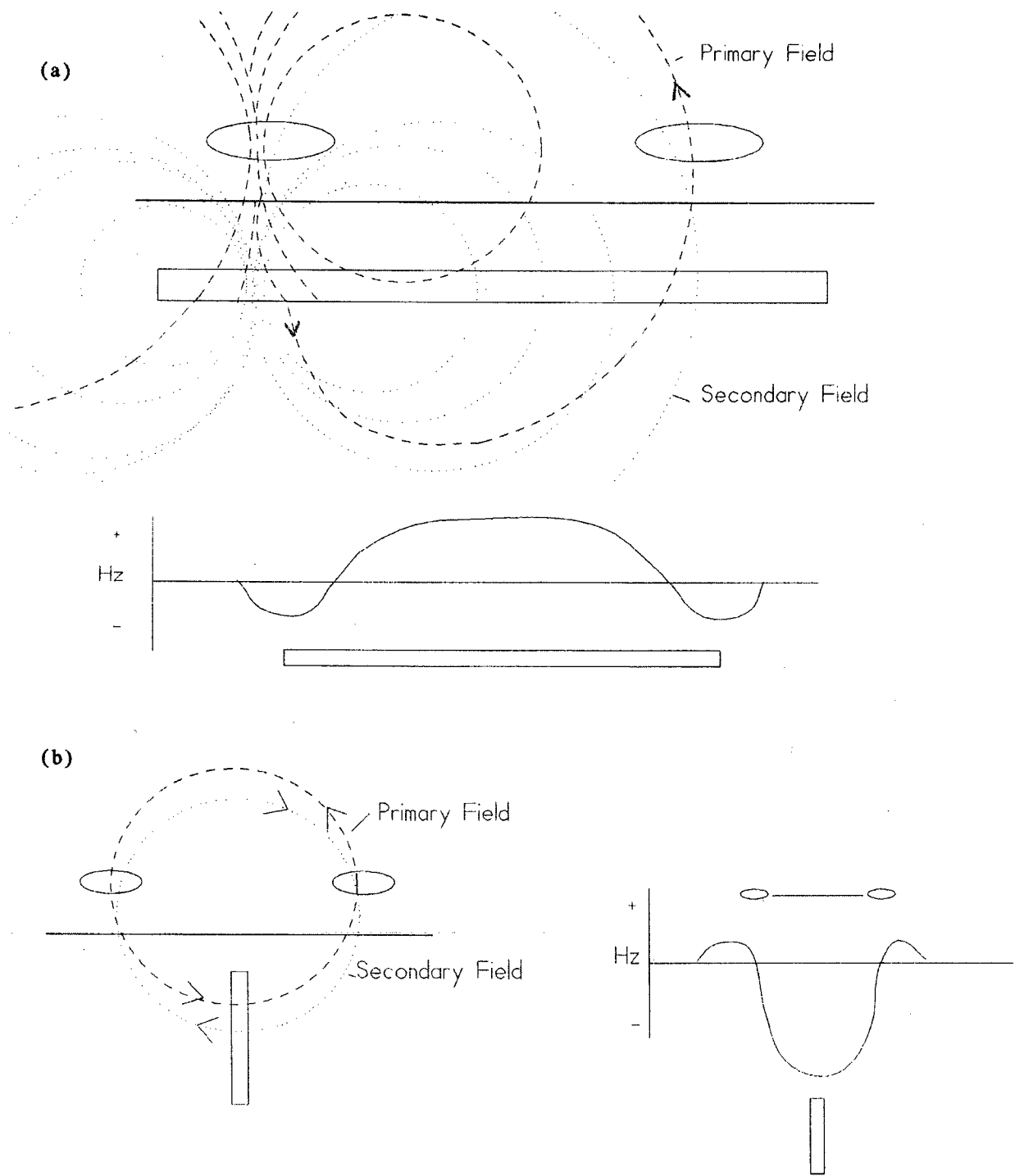

Figure MM2. HLEM responses. (a) Response over a flat-lying conductor consists of a positive response. (b) Response over a dipping conductor consists of a negative response

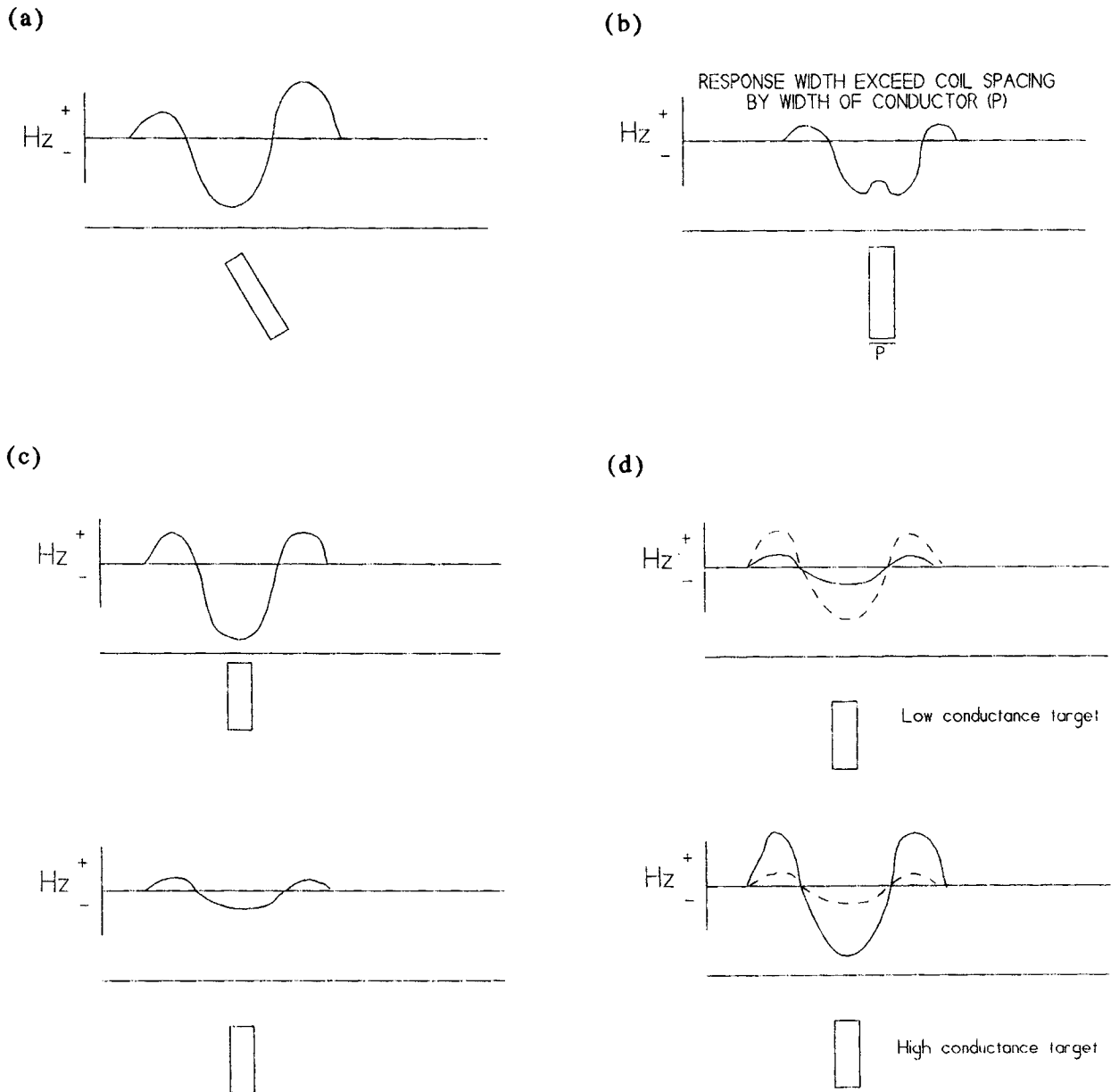

Figure MM3. HLEM response of dipping tabular conductors. (a) Effect of dip on HLEM response. (b) Effect of conductor width. (c) Effect of depth. (d) Effect of conductance.

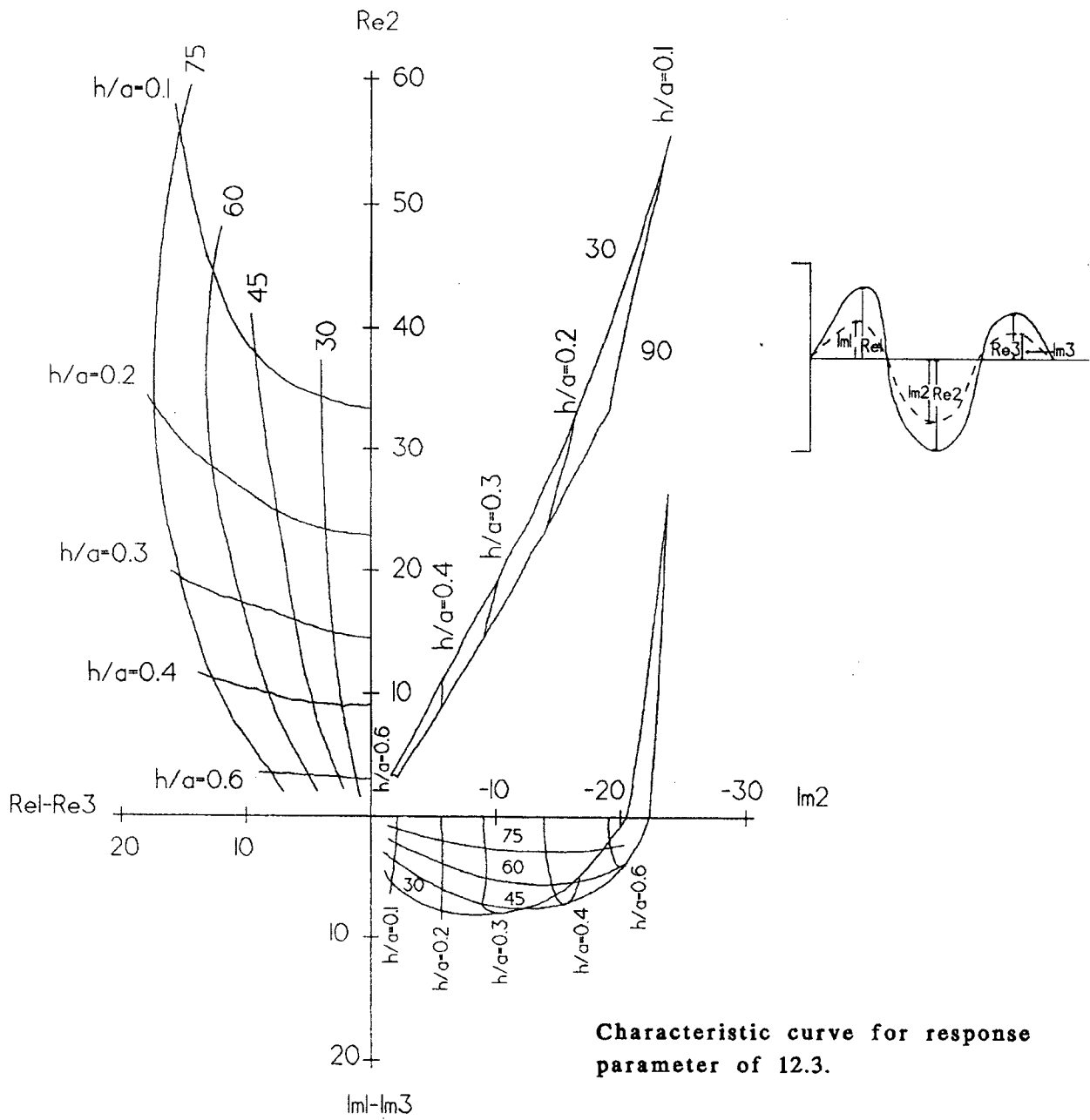

Figure MM4. Characteristic curve for a dipping tabular conductor from Ketola and Puranen (1967). Critical measurements of the response shown in the upper right are extracted and plotted to determine the geometry and conductance of the target.

Interpretation procedures for HLEM data are dependent upon the model to which the data is to be fitted. In most cases, the characteristic shape of the response will dictate the likely overall geometry of the source and thus the model to which the response should be fitted. Flat lying targets can be directly modeled with computerized calculations of target responses. Dipping tabular body responses on the other hand cannot be numerically modeled and must either be approximated through finite-element models or interpreted using characteristic curves. Characteristic curves for tabular dipping conductors incorporate several key features of the responses described in Figure MM3 into simple charts. These responses are derived from model experiments. The ratio of positive shoulders responses and the ratio of in-phase to quadrature peak negative values are the commonly used features of the response. An example of these charts is shown in Figure MM4.

The data contained in this report was interpreted using characteristic curves developed by Ketola and Puranen (1967). The procedure, normally done by hand, has been automated in proprietary software (MMPLOT) developed by Aurora Geosciences Ltd. The characteristics of each response are entered into a computer program, which creates a batch-plotting file. The data is plotted directly on a CADD diagram with each of the characteristic curves on a different layer. The operator is able to quickly match the data to the curve that best fits the data by selecting different characteristic curves (i.e. by changing layers). Where the data falls between two curves, the conductance and depth to top parameters can be interpolated but the dip cannot be reliably interpolated.

9.0 RESULTS

Besshi-style volcanogenic massive sulphide mineralization characteristically displays both very low electrical resistivity and moderate to high magnetic susceptibility. Typical target response consists of a very high conductance (>40S) source conductor with a coincident magnetic field high (Palacky, 1987). This is attributable to the presence of pyrrhotite and chalcopyrite. The HLEM survey carried out by Casselman (2003) located two discrete dipping conductors (UL-1 and UL-2) in an area possibly underlain by a flat lying (surficial?) conductor. The anomalies as described by Casselman (2002) follow below:

Anomaly UL-1

Anomaly UL-1 extends from L9000N 9525E to L9200N 9650E. The response consists of a wide trough with subsidiary flanking highs at 3520 and 7040 Hz; there is little to no response at lower frequencies. The responses appear to show excess width in the order of 50 or more meters. The source conductor would appear to be very weak (< 1S), quite wide (40-80 m), and east dipping. The conductance is well below the range expected for massive sulphide mineralization. The substantial width of the target suggests that it might be a discrete stratigraphic unit. The depth to the top of the conductor increases from 30 m in the south to 60 m in the north. This conductor occurs on the east flank of a broad total magnetic field high. The association between the conductor and the high is strongest on L9200N.

Anomaly UL-1

Apex Location	Depth to top (m)	Dip / Dip Direction	Excess width (m)	Conductance (Siemen)
L9000N 9525E	35	60°E	40	0.36
L9100N 9550E	40	?E	60	0.63
L9200N 9650E	60	?E	80	0.45

Anomaly UL-2

Anomaly UL-2 extends from L9000N 10275E to L9200N 10300E. A subsidiary splay, evident as a minor deflection in the adjoining anomaly occurs at L9000N 10150E. The anomaly consists of a trough with subsidiary flanking highs at all frequencies. The responses are nearly saturated at 7040 Hz where the quadrature response is almost completely suppressed on L9100N. The responses show no excess width, suggesting that the source is less than 12.5 m wide. The source conductor would appear to be a slightly conductive (3-9 S), steeply east dipping, thin tabular body. The depth to the top of the source conductor appears to be 60 to 80 m. The source conductance is at the lower limit of conductances normally expected from massive sulphide deposits and is well below the range expected for Besshi-style mineralization. On L9000N and L9100N, the conductor is associated with a discrete total magnetic field high located immediately east of the conductor axis. The shape of the total magnetic field high suggests that the source dips steeply to the east.

There is a region of low resistivity from L9500N 9100E to L9500N 9500E, evident in the 880 Hz through 7040 Hz responses. It may be caused by a bedrock conductor striking parallel to the survey line or by a flat lying surficial conductor. There is no associated total magnetic field response.

Anomaly UL-2

Apex Location	Depth to top (m)	Dip / Dip Direction	Excess width (m)	Conductance (Siemen)
L9000N 10275E	60	?	0	3.6
L9100N 10300E	80	?	0	8.9
L9200N 10300E	70	60° - 75° E	0	3.8
L900N 10150E	?	?	?	<1.0

10.0 CONCLUSIONS

The HLEM survey extension did not locate any new conductive areas on the Ultra Grid. The 2003 HLEM survey extension are largely inconclusive due to the short line lengths relative to the coil spacing and the noise associated with the data. While the HLEM extension does not allow for new interpretations, the conclusions and recommendations made by Casselman (2003) still apply. The

results of the 2002 HLEM survey suggest the following conclusions as described by Casselman (2003):

- a. Conductor UL-2 appears to be located at the base of a magnetically susceptible, east dipping rock unit. It has a conductance at the lower limit of what would normally be expected for a massive sulphide body. The source conductor is thin (<12.5 m) and subcrops at a depth of 60 to 80 m. The conductor is open to the north and south.
- b. Conductor UL-1 has a source, which appears to be a wide (60 to 80 m), steeply east dipping, poorly conductive tabular conductor at a depth to top of 30 to 60 m. The width of the target and the poor conductance suggests that it is likely a weakly conductive rock unit rather than massive sulphide mineralization. The conductor does not appear to be intimately associated with any magnetic bedrock sources.

11.0 RECOMMENDATIONS

As previously mentioned the recommendations made by Casselman (2003) are still applicable to the Ultra property. The following recommendations are listed as described by Casselman (2003).

- a. Geological mapping of the area, especially in the Telluride creek valley where there is a fair amount of outcrop, to assist in determining the orientation of geological structures, which will aid a drilling program.
- b. Test conductor UL-2 to determine its' cause by drilling.
- c. If the drilling program identifies a favorable horizon, the HLEM and magnetic surveys should be extended to the northeast and south to trace the extent of the conductors UL-1 and UL-2. Extension of the geophysical surveys may also help to identify an area where the conductors are at a shallower depth.

Respectfully submitted,
AURORA GEOSCIENCES LTD.



Phil Jackson B.Sc. P.Geoph.
Geophysicist

12.0 REFERENCES

- Casselmann, S. (2003) Horizontal Loop Electromagnetic, Total Magnetic Field and VLF-EM Surveys on the Ultra Property, Haines Junction Area, Yukon Territory
- Gordey, S. P. and Makepeace, A. J., 1999. Yukon Digital Geology. Exploration and Geological Services Division, Yukon, Indian and Northern Affairs Canada, Open File 1999-1 (D).
- Ketola, M. and M. Puranen (1967) Type curves for the interpretation of Slingram (horizontal loop) anomalies over tabular bodies. Geological Survey of Finland Report of Investigations No. 1.
- Palacky, G.G. (1987) Resistivity characteristics of geologic targets.
in: Nabighian, M.N. (ed.) Electromagnetic Methods in Applied Geophysics - Theory (Volume I). Tulsa: Society of Exploration Geophysicists.
- Telford, W.M., L.P. Geldart and R.E. Sheriff (1990) Applied Geophysics (2nd Edition) New York: Cambridge University Press.
- Varre, T. (1990) Apex Parametrics Maxmin I-9 manual. Uxbridge: Apex Parametrics.

APPENDIX A STATEMENT OF QUALIFICATIONS

STATEMENT OF QUALIFICATIONS

I, Philip Jackson, of the City of Yellowknife, in the Northwest Territories, Canada,

HEREBY CERTIFY:

That my address is 5211 Brock Drive, Yellowknife, N.W.T. X1A 1Z8

That I am a graduate of Concordia University in Geology/Physics:
B.Sc. - Concordia University, 1996

That I have been a practising Geophysicist since 1997:
January 1997 - December 2000 Covello, Bryan & Associates Ltd.
Yellowknife, N.W.T.
Geophysicist
January 2001 to present Aurora Geosciences Ltd.
Yellowknife, N.W.T.
Geophysicist

That I am registered as a Member by The Association of Professional Engineers, Geologists and Geophysicists of the Northwest Territories (Registration Number 1667).

That I am entitled to practice as a Professional Geophysicist in the Northwest Territories and Nunavut.

Dated this 14th day of JANUARY, 2004 at Yellowknife, N.W.T.

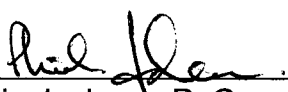

Philip Jackson, P. Geoph.

Statement of Expenditures on Ultra 39, 41, 75, & 77

Claude Audet 5days line cutting @ \$300.00/day x 5 days.....	\$1500.00
5days chainsaw rental @ \$35.00/day x 5 days.....	\$ 175.00
Travel from Dawson to Whitehorse and back.....	\$ 200.00
Tom Morgan 5 days Max – Min Survey Assistance @ \$300.00/day.....	\$1500.00
Chainsaw rental @ \$180/wk x 2 wks.....	\$ 360.00
Truck rental @ \$390/wk x 1.5 wks.....	\$ 585.00
Darcy MacGillivray 5days line cutting @ \$300.00/day x 5 days.....	\$1500.00
Remi Dionne 5 days line cutting @ \$300.00/day x 5 days.....	\$1500.00
5 days chainsaw rental @ \$35.00/day.....	\$ 175.00
Andrew Robinson 5days line cutting @ \$300.00/day x 5 days.....	\$1500.00
Aurora Geosciences Max Min geophysics contract.....	\$4012.50
Aurora Geosciences report 1819.00 x 0.5.....	\$ 909.50
Home Hardware (lath).....	\$ 107.13
 Total.....	 \$15699.13

This work was done between Oct 19 to Oct 23 as explained in Aurora's report

APPENDIX B SURVEY LOG



AURORA GEOSCIENCES LTD.
PROJECT LOG
TOM MORGAN
ULTRA PROPERTY
HLEM EXTENSIONS SURVEY

Period: September 30 - October 20, 2003

Personnel: Ron Joly (RJ) - Geophys Tech

Sat, Oct 18 Felix Gagne, Ron Joli Organize camp in AM. Tom Morgan arrives in afternoon to pick-up camp gear and ATV. Felix to drive Ron to camp next morning.

Sun, Oct 19 Ron and Felix depart for Ultra camp at 9:00 AM. Unload gear at camp site and Felix returns to Whitehorse with truck, arriving at 5:00 PM.

Mon, Oct 20 Ron helps to establish line with Tom Morgan's crew.

Tue, Oct 21 Ron starts HLEM survey with Tom Morgan as hoop man. Run extensions to 2002 survey.

Production: 2,500 m of Maxmin

Wed, Oct 22 Cold windy and snowy. Ron and Tom continue HLEM survey. Weather deteriorates, very windy and snowy through night.

Production: 1,700 m of Maxmin

Thur, Oct 23 Heavy snow and wind through night. Decide to abandon further surveying and Tom drives Ron back to Whitehorse with HLEM gear and some camp gear.

Fri, Oct 24 Ron flies back to Yellowknife at 12:30. Tom comes into office in afternoon. Tom will continue working property and will rent ATV and some camp gear for 4-5 days (\$75/day).

APPENDIX C FIELD MAPS

**YUKON ENERGY, MINING
& RESOURCES LIBRARY**
P.O. Box 2703
1430 Brantingham Mall, Whitehorse, Yukon

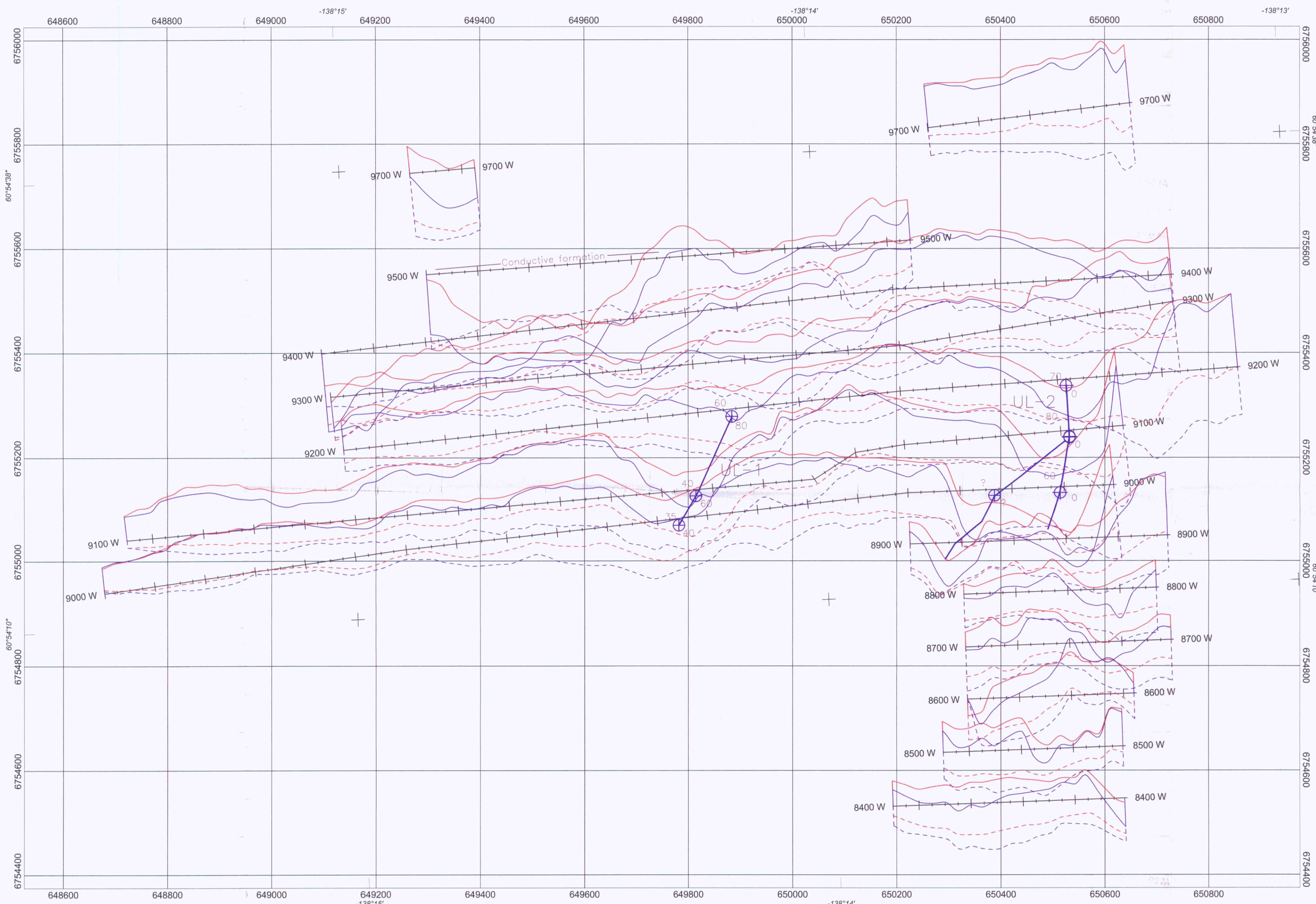

LOCATION MAP - ULTRA GRID

LEGEND
HORIZONTAL LOOP EM

FREQUENCY : 3520 and 7040 Hz
 INSTRUMENT : APEX PARAMETRICS MAX-MIN I-9
 PROFILE SCALE : 1 cm = 20%
 IN PHASE : ————
 QUADRATURE : - - - - -

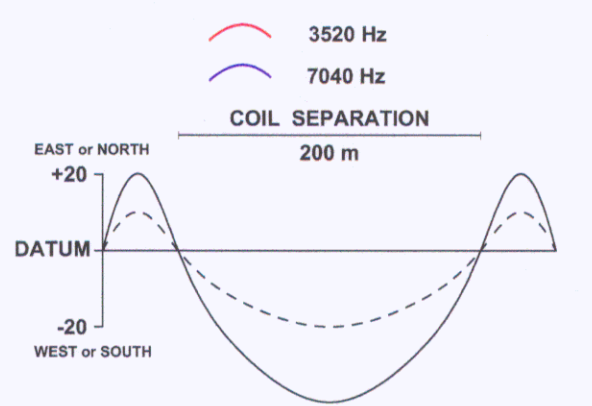

IN-PHASE DATUM : 0%
 QUADRATURE DATUM : 0%
 DATA FILE : ULTRA_HLEM.gdb
 OPERATORS : RJ, SC, TM
 STATION SEPARATION : 25m
 LINE-KM SURVEYED THIS SHEET : 12.875 km

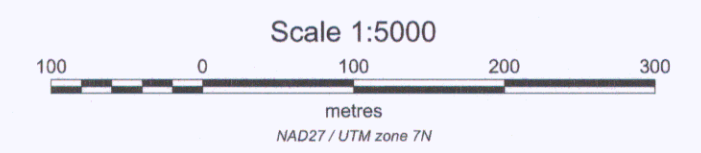

EM ANOMALY SYMBOLS

- Unknown
 - ⊕ <1 S
 - ⊕ 1-5 S
 - ⊕ 5-10 S
 - ⊕ 10-40 S
 - ⊕ >40 S
- Depth (m)
- ⊕ Excess width (m)

YUKON ENERGY
 & RESOURCES
 P.O. BOX 2703
 Whitehorse, Yukon Y1A 0K6

TOM MORGAN

Ultra Property
HORIZONTAL LOOP ELECTROMAGNETIC SURVEY
 YUKON TERRITORY, CANADA

DATE SURVEYED : Sept 2002 and Oct, 2003
 NTS 115B/16
 Map name: Hlem_ext_35_70.map
 DATE/DRAWN BY: (19-12-03/PJ)

AURORA GEOSCIENCES Ltd.

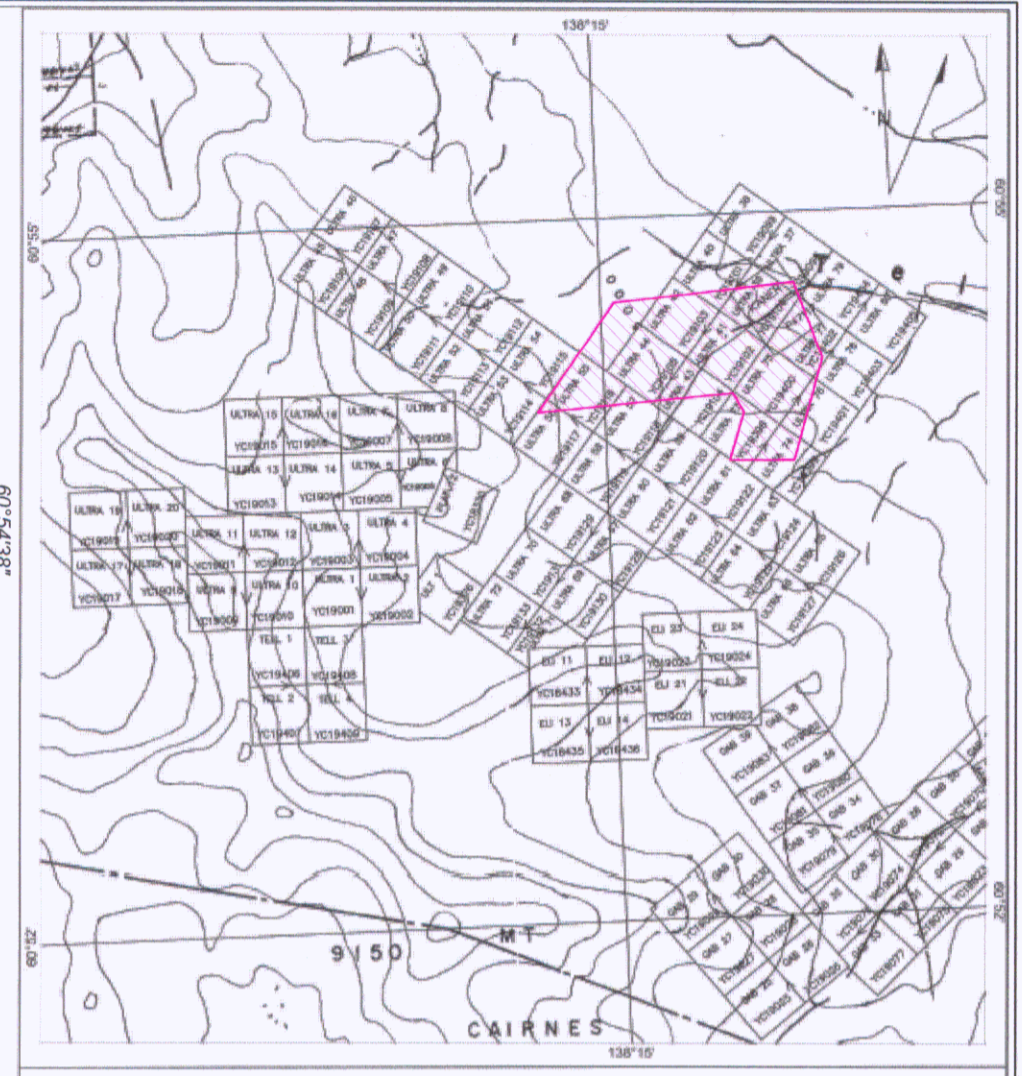
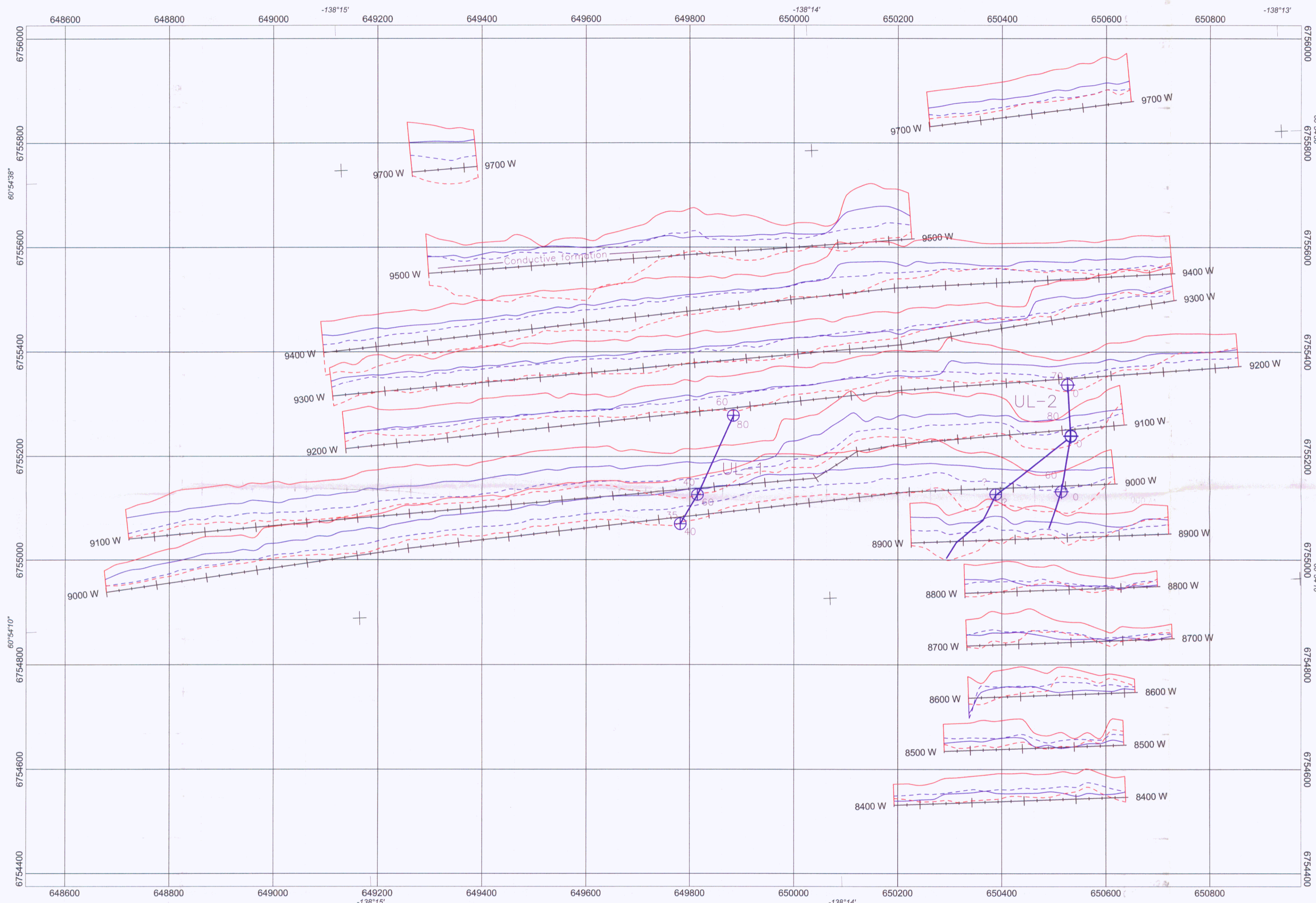

LOCATION MAP - ULTRA GRID

LEGEND
HORIZONTAL LOOP EM

FREQUENCY : 220 and 880 Hz
 INSTRUMENT : APEX PARAMETRICS MAX-MIN I-9
 PROFILE SCALE : 1 cm = 20%
 IN PHASE : _____
 QUADRATURE : - - - - -

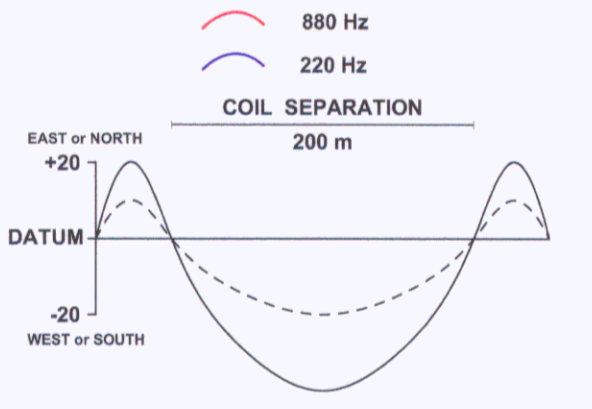

IN-PHASE DATUM : 0%
 QUADRATURE DATUM : 0%
 DATA FILE : ULTRA_HLEM.gdb
 OPERATORS : RJ, SC, TM
 STATION SEPARATION : 25m
 LINE-KM SURVEYED THIS SHEET : 12.875 km

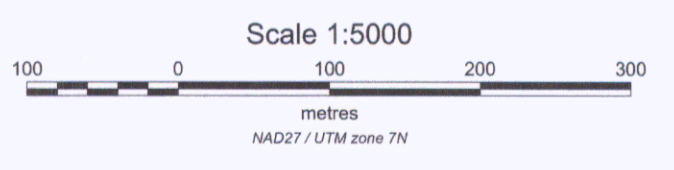

EM ANOMALY SYMBOLS

- Unknown
 - ⊕ <1 S
 - ⊕ 1-5 S
 - ⊕ 5-10 S
 - ⊕ 10-40 S
 - ⊕ >40 S
- Depth (m)
- Excess width (m)

YUKON ENERGY, MINES & RESOURCES LIBRARY
 P.O. Box 2703
 Whitehorse, Yukon Y1A 2C8

TOM MORGAN

Ultra Property
HORIZONTAL LOOP ELECTROMAGNETIC SURVEY
 YUKON TERRITORY, CANADA

DATE SURVEYED : Sept 2002 and Oct, 2003
 NTS 115B/16
 Map name: Hlem_ext_22_88.map
 DATE/DRAWN BY: (19-12-03/PJ)

AURORA GEOSCIENCES Ltd.

Statement of Expenditures on ULT 1

Darcy MacGillivray @ \$300/day x 13 days.....	\$ 3900.00
(hand trenching, pad building, packing gear in and out)	
Andrew Robinson @ \$300/day x 11 days.....	\$ 3300.00
Tom Morgan @ \$300/day x 13 days.....	\$ 3900.00
Report preparation.....	\$ 900.00
Truck rental @ \$390/wk x 1.5.....	\$ 585.00
Prospects North expediting.....	\$ 250.00
Explosives.....	\$ 892.60
Expedibles (sample bags, ect).....	\$ 87.36
Aurora rental of 4 wheeler and camp @ \$561.75/wk.....	\$ 561.75
Aurora report \$1819.00 x .5.....	\$ 909.50
Total.....	\$15286.21

Work was done on the following dates Sept. 21 to 25, Oct 14 to 15, & Oct. 25 to 30 doing hand work and packing gear to make a 20' x 15' x 5' pad for compressor and gear as well as a hand trench measuring 20' x 10' x 8' on Froberg showing.