

TOE PROPERTY

**1997 ASSESSMENT REPORT
DESCRIBING GEOCHEMICAL AND GEOPHYSICAL
SURVEYS ON THE TOE 1-36 AND JILL 1-41
CLAIMS, FINLAYSON LAKE AREA, YUKON TERRITORY
DATES WORKED: 05/05/97 – 30/08/97**

**NTS 105G/8,9
61°30'N/130°25'W
Watson Lake Mining Division**

093782

Prepared for

**Westmin Resources Limited
Suite 904-1055 Dunsmuir Street
Vancouver, B.C., Canada
V7X 1C4**

by

David A. Terry, Ph.D.

March, 1998

[Faint circular stamp, likely a library or archival mark, with illegible text]

Regional Manager, Exploration and
Geological Services for Commissioner
of Yukon Territory.

M. G. ...

for

This report has been examined by
the Geological Evaluation Unit
under Section 83 (4) Yukon Quartz
Mining Act and is allowed as
representation work in the amount
of \$ 31,600.00.

TABLE OF CONTENTS

1.0	INTRODUCTION	4
2.0	LOCATION, ACCESS, AND PHYSIOGRAPHY	4
3.0	LIST OF CLAIMS AND OWNERSHIP	6
4.0	PREVIOUS WORK	6
5.0	REGIONAL GEOLOGY	6
6.0	SOIL SAMPLIING	12
7.0	GROUND GEOPHYSICS	13
8.0	CONCLUSIONS AND RECOMMENDATIONS	14
	REFERENCES	15
	APPENDIX	

LIST OF TABLES

6.1	Soil Geochemical Statistics	13
-----	-----------------------------	----

LIST OF FIGURES

1.0	Property Location Sketch	5
2.0	Claim Location Sketch	7
3.1	Tectonic Setting Map	8
3.2	Regional Geology Map	11
6.1	Au in Soil (1:10,000)	Appendix G
6.2	Ag in Soil (1:10,000)	Appendix G
6.3	Cu in Soil (1:10,000)	Appendix G
6.4	Pb in Soil (1:10,000)	Appendix G
6.5	Zn in Soil (1:10,000)	Appendix G
6.6	Ba in Soil (1:10,000)	Appendix G
TO-1	Maxmin I-10 Survey @ 440 Hz (1:5,000)	Appendix G
TO-2	Maxmin I-10 Survey @ 880 Hz (1:5,000)	Appendix G
TO-3	Maxmin I-10 Survey @ 1760 Hz (1:5,000)	Appendix G
TO-4	Maxmin I-10 Survey @ 3520 Hz (1:5,000)	Appendix G
TO-5	Total Magnetic Field Survey Contour Map (1:5,000)	Appendix G

LIST OF APPENDICES

A	Statement of Expenditures
B	List of Claims
C	List of Personnel
D	Geologists Certificate
E	Assay Certificates
F	Geophysical Report
G	Oversize Figures

1.0 INTRODUCTION

The 1996 field program on the Toe property comprised line-cutting, grid soil sampling, geologic mapping and rock sampling, and diamond drilling. The 1997 field program was carried out between May 5 and August 30, 1997 and included line-cutting, soil sampling, and ground geophysics. Line-cutting was contracted to Nitro Enterprises of Atlin, B.C., a ground MAG and MAXMIN survey was carried out by Amerok Geosciences of Whitehorse, Yukon, and soil sampling was carried out by Westmin Resources Limited field personnel. In total 26.7 km of grid line was cut and surveyed on the property. All work was supervised by the author.

2.0 LOCATION, ACCESS AND PHYSIOGRAPHY

The Toe claims are located 125 km southeast of the village of Ross River and 90 km northwest of Watson Lake in the southeastern Yukon Territory as shown on Figure 1.0. The claims are centered about 61°30'N and 130°25'W and straddle the boundary between NTS map sheets 105G/8 and 105/G9. Access to the property is by helicopter which can be chartered in either Ross River or Watson Lake. The Robert Campbell Highway which runs between Ross River and Watson Lake lies approximately 15 km north of the property. A 4-wheeler road accesses the eastern part of the Toe property where a cabin is located on the shore of the northern portion of Wolverine Lake.

The Toe claims are within the Pelly Mountains, a sub-division of the Yukon Plateau physiographic region of the northern Cordillera. The Toe property lies on the southwest flank of the Campbell Range, just off the north-west end of Wolverine Lake. Elevations on the property range from 1140 meters to 1500 meters above sea level. The entire property is below treeline and black spruce and buck brush dominate the vegetative cover. Wind Lake divides the claim

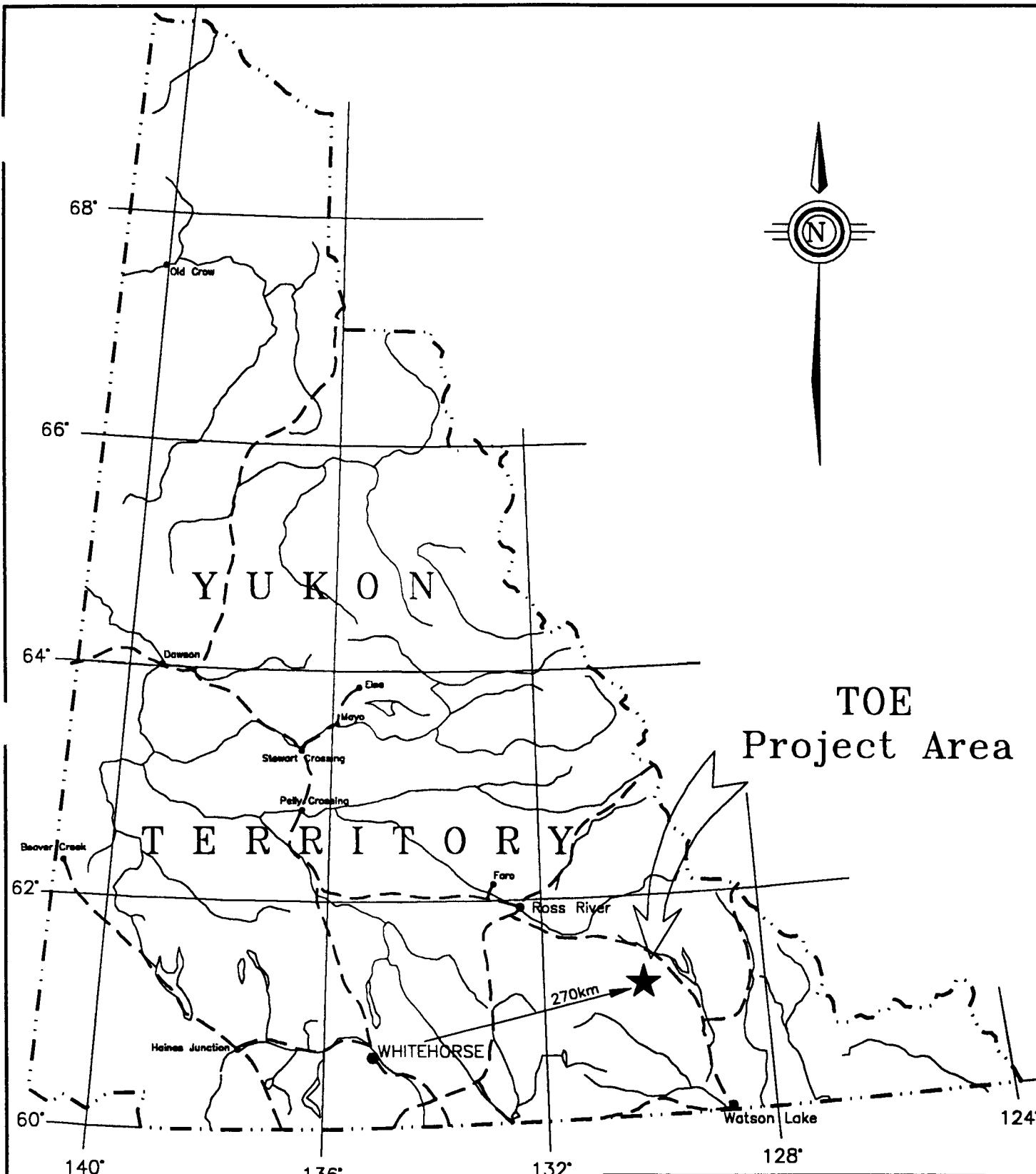

	WESTMIN RESOURCES LIMITED	
Work By Westmin	TOE PROJECT	
Date Drafted Nov. 24, 1988	Property Location Sketch	
Drafted By A. Turner		
N.T.S. Number	50 0 50 100 150km	Figure
File Name TOE_LOC.DWG	Scale 1 : 2 500 000	1.0

group forming northern and southern portions of the property, both of which are moderate forested slopes. Outcrop exposure is poor (< 5%), the most significant occurring parallel to and north of Wind Lake.

3.0 LIST OF CLAIMS AND OWNERSHIP

Claim names, record numbers, record dates, and expiry dates for the claims covered by this report are given in Appendix C. The due dates shown have been updated to reflect the current assessment filing. The distribution of the Toe (1-36) and Jill (1-41) claims is shown by Figure 2.0. The claims are subject to a 60/40 joint venture between Westmin Resources Limited of Vancouver B.C. and Atna Resources Ltd. of Vancouver B.C., respectively.

4.0 PREVIOUS WORK

Aside from government mapping, geochemical and geophysical surveys, known work in the area comprises several reconnaissance mapping and sampling traverses carried out in 1995, and the line-cutting, soil sampling, mapping, and diamond drilling carried out in 1996 by Westmin Resources Limited (Bradshaw et al., 1996). Most previous work in this region concentrated on the area around the Wolverine Deposit. A brief summary of that work is given in Baknes and Weber (1996).

5.0 REGIONAL GEOLOGY

The property is situated within the Finlayson Lake belt of the southeastern Yukon, an elongate composite body bounded on the southwest by the Tintina Fault Zone and on the northeast by the Finlayson Lake Fault Zone (Figure 3.1). The Tintina Fault Zone is a major transcurrent structure along which approximately 450 km of dextral offset occurred in Late Cretaceous and/or early

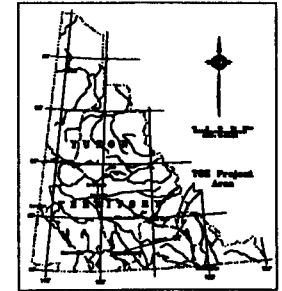
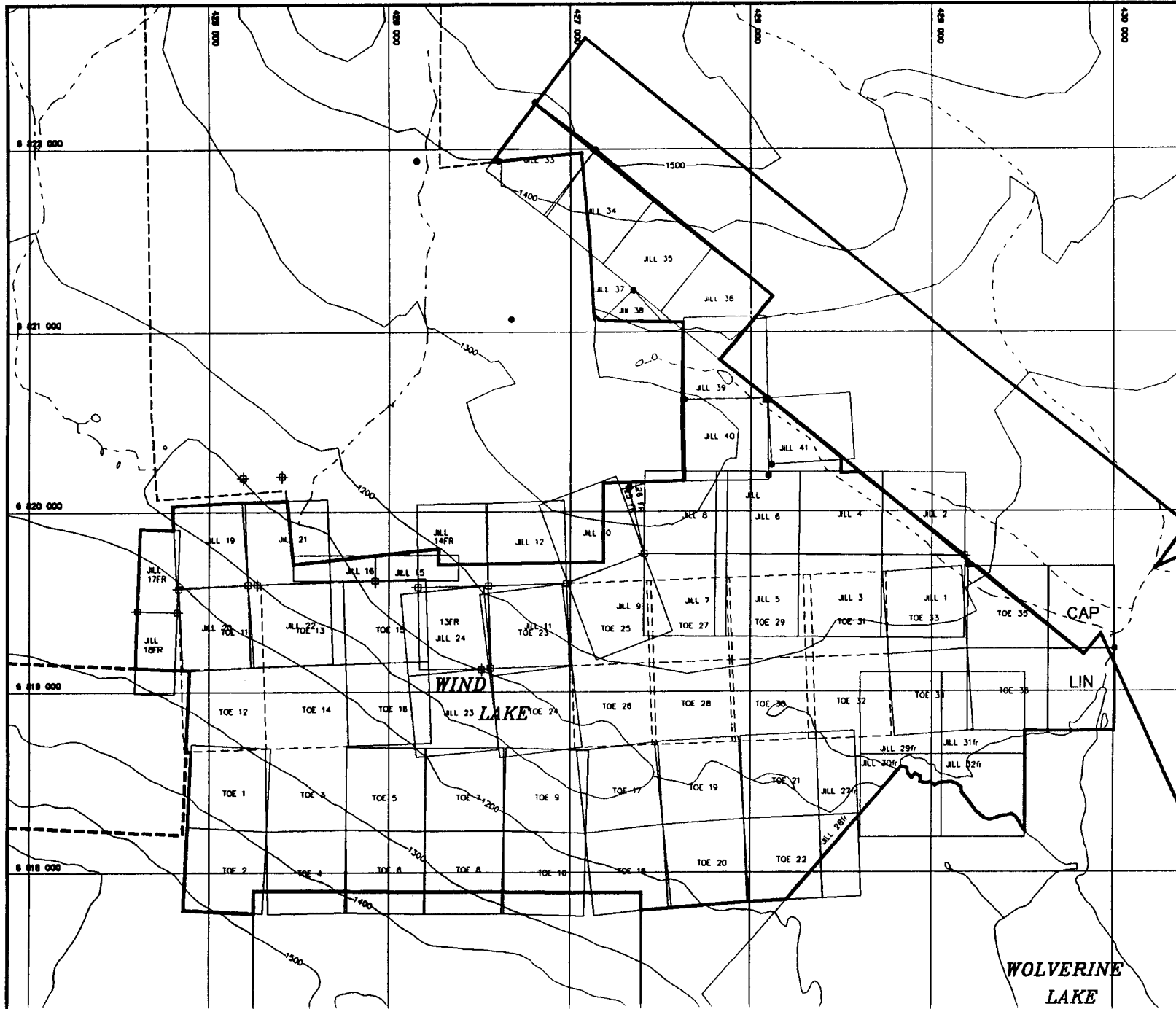





LOCATION MAP

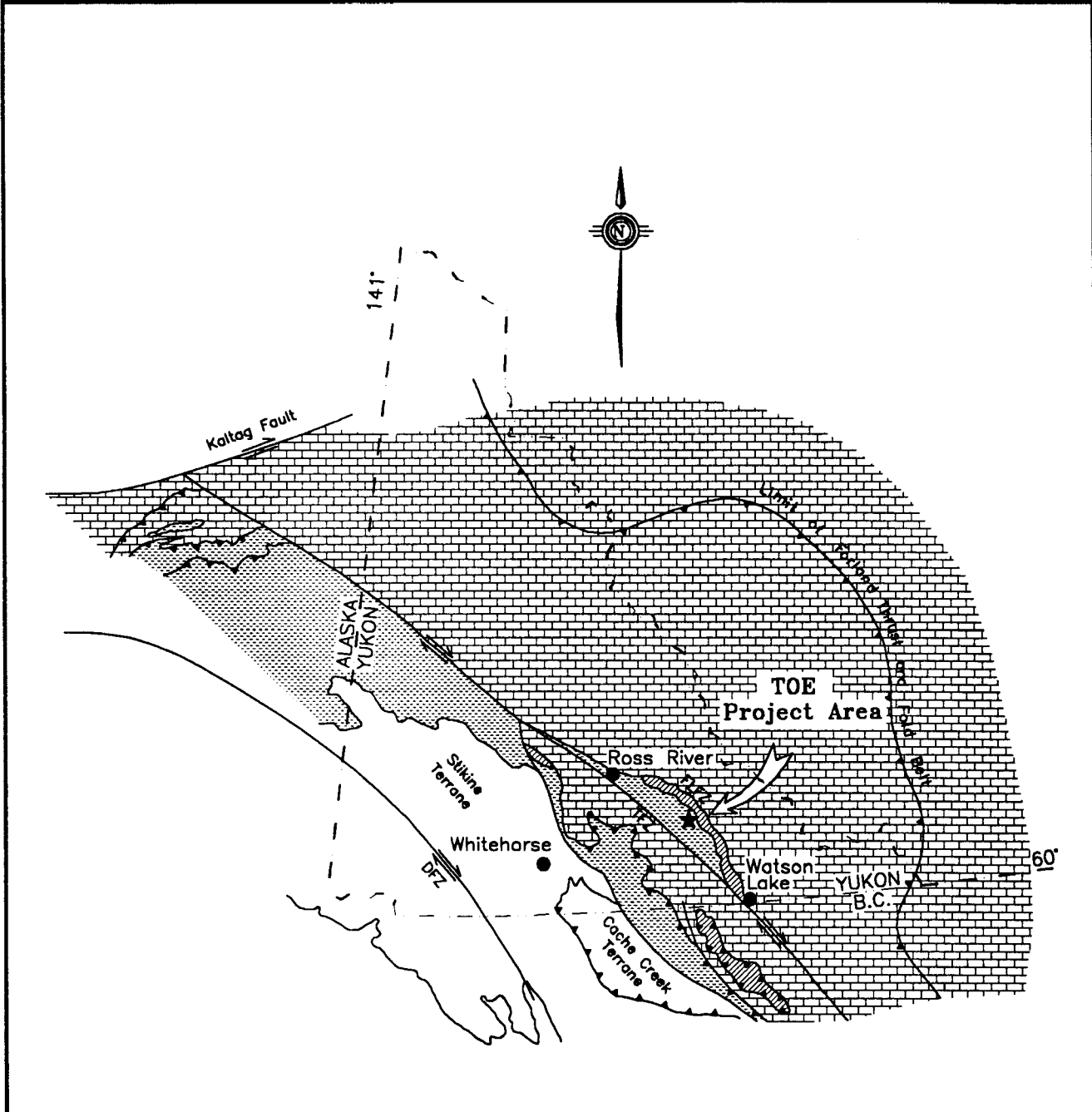

WESTMIN RESOURCES LIMITED	
ATMA RESOURCES LTD.	
TOE Property Claims 17-36	
Claim Location Map	
Drawn By: [] Checked By: [] Date: [] Scale: 1:50,000 Project: [] File Name: [] Date: []	Scale: 0 200 400 600 meters 0 200 400 600 feet 2.1



LEGEND

-  North American Miogeoclinal Strata
-  Yukon - Tanana Terrane
-  Slide Mountain Terrane
-  Thrust Fault
-  Strike-Slip Fault, with sense of movement
 - FLFZ - Finlayson Lake Fault Zone
 - TFZ - Tintina Fault Zone
 - DFZ - Denali Fault Zone

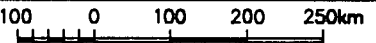
	WESTMIN RESOURCES LIMITED	
	TOE PROJECT	
Work By	Tectonic Setting after Mortensen and Jllson (1985)	
Date Drafted		
Nov. 24, 1996		
Drafted By		
A.T. & J.K.	 Scale 1 : 10 000 000	
N.T.S. Number		
File Name		
YUK_TAN.DWG	Figure	3.1

Tertiary time (Tempelman-Kluit et al., 1976). The Finlayson Lake Fault Zone is described by Mortensen (1996, personal communication) as a complex structure which may in part represent a transpressive dextral paleosuture.

Much of the Finlayson Lake belt is underlain by rocks grouped with the Yukon Tanana Terrane (YTT) by Mortensen and Jilson (1985). The YTT underlies a large area of western to southeastern Yukon and east-central Alaska. The YTT rocks in the Finlayson Lake Belt are believed to be offset along the Tintina Fault from the main body of the YTT in the western Yukon. Mortensen (1992) has divided the YTT in the Yukon into 3 main structural assemblages: 1) the Nisling assemblage, a lower quartzite and marble package of possible Proterozoic and/or Cambrian age; 2) the middle Nasina assemblage, a package of Late Devonian to mid Mississippian carbonaceous metasedimentary and mafic to felsic metavolcanic rocks; and 3) an upper package of mid-Permian felsic metavolcanics (Klondike Schist) and metaplutonic rocks. Recent interpretations conclude that the YTT represents a mid-Paleozoic volcanic-plutonic arc assemblage built on continental crust (Nokleberg and Aleinikoff, 1985; Mortensen and Jilson, 1985; Foster et al., 1987; and Mortensen, 1992). Although the andesitic volcanics one would expect to be voluminous in a continental margin arc setting are seemingly not present in the Finlayson Lake Belt, Mortensen (1996, personal communication) suggests that large K-feldspar megacrystic granitoids which form part of the core of the belt are intermediate in composition and therefore, together with the volcanics, represent a differentiated igneous suite.

Regional metamorphism throughout the YTT ranges from very low grade to amphibolite facies. Radiometric dating suggests that metamorphic events may have occurred at different times in different subterranean. Mortensen and Jilson (1985) have subdivided the YTT in the Finlayson Lake Belt into six major lithologic packages: 1) a sequence of layered metasediments and metamorphic rocks; 2) Paleozoic metaplutonic rocks; 3) middle to late Paleozoic mafic and

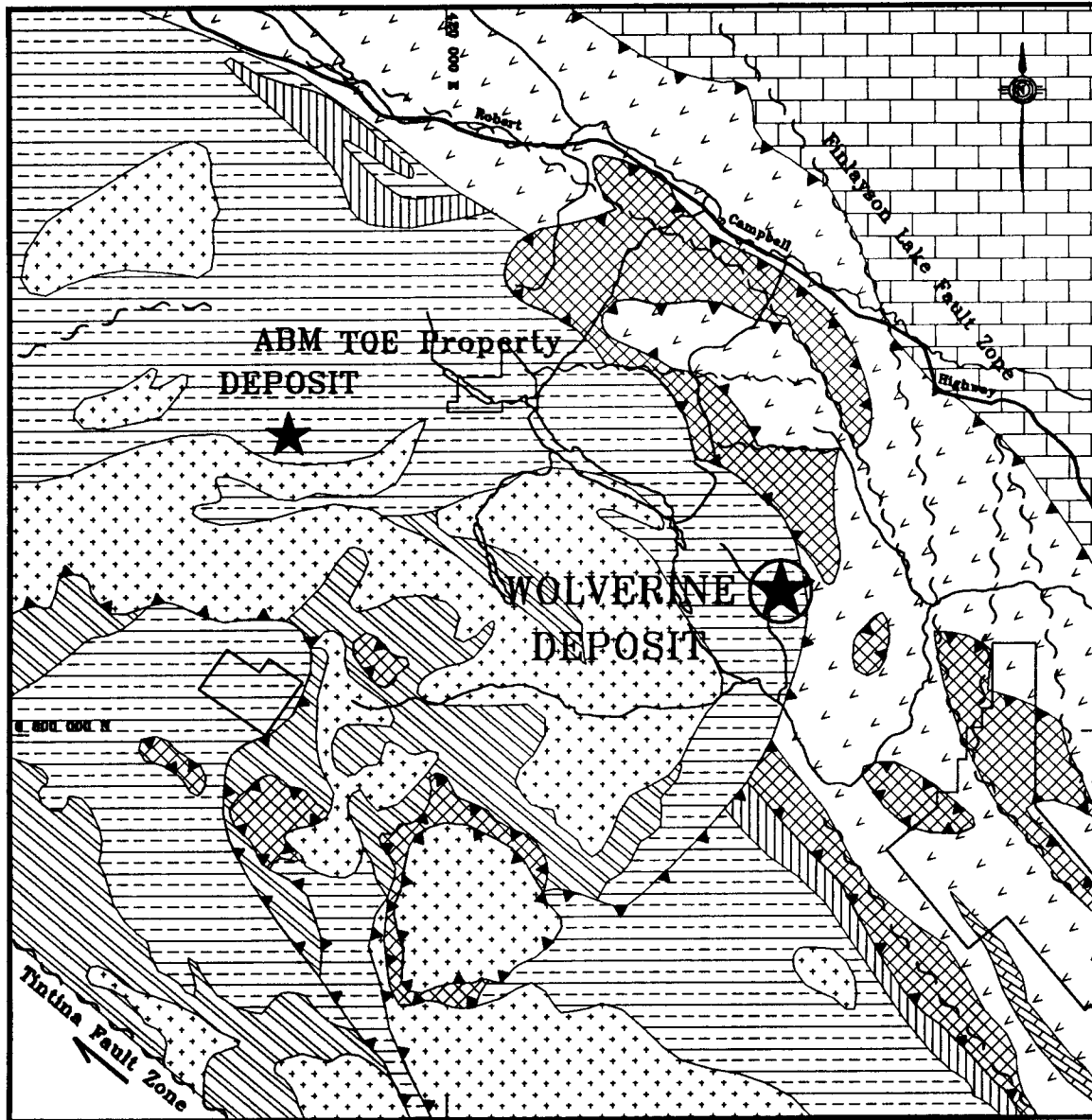

ultramafic igneous rocks and chert; 4) early Mesozoic clastic rocks; 5) Mesozoic plutonic rocks; and 6) Late Cretaceous and/or early Tertiary volcanic rocks (Figure 3.2). The layered metamorphic package (LMP) is approximately 3 km thick and is divisible into: 1) a lower Devonian and older quartz+mica+/-garnet schist and quartzite package with an upper marble/calcareous schist unit; 2) a middle dark siliceous to carbonaceous phyllite unit interlayered with mafic and felsic volcanics. U-Pb zircon ages of the felsic metavolcanics range from Late Devonian to mid-Mississippian; and 3) an upper white carbonate/quartzite package of Early Pennsylvanian to Permian age (Mortensen and Jilson, 1985). Paleozoic metaplutonic rocks are divided by Mortensen and Jilson (1985) into: 1) the Simpson range plutonic suite of quartz-monzonite to quartz-diorite (349-359 Ma, U-Pb zircon); 2) augen orthogneiss (342 Ma, Rb-Sr); and 3) monzonitic orthogneiss (340-345 Ma, U-Pb zircon). The first two are considered to have an intrusive relationship with the lower LMP due to pyritization of wallrocks in the case of the Simpson suite and a hornfelsed aureole bordering the augen orthogneiss.

Large bodies of massive to pillowed greenstone, chert, and variably serpentinitized ultramafic to mafic plutonic rocks are common in the northeastern portion of the Finlayson Lake belt and have been interpreted (Tempelman-Kluit, 1979 and Mortensen and Jilson, 1985) as fragments of a dismembered ophiolite. Tempelman-Kluit (1979) mapped these rocks as part of the Anvil allochthon whereas they are referred to as the Campbell Range Belt by Mortensen and Jilson (1985). They are thought to correlate with the Slide Mountain terrane in British Columbia and based upon U-Pb zircon dates and fossil ages they range from latest Devonian to Early Permian in age. The southern portion of the Finlayson Lake Fault Zone adjacent to the Wolverine Lake area is overlapped by thrust sheets of the Campbell Range Belt in a flower-fault structural relationship (Mortensen, 1996 personal communication). The ophiolitic package is interpreted to have been thrust from northeast to southwest otop of the middle package of the LMP in the Wolverine Lake area.







GEOLOGICAL LEGEND





Slide Mountain Terrane

-  Carbonate Rocks
-  Metavolcanic Rocks and Cherts
-  Ultramafic Rocks

Nisutlin Subterrane and Pelly Gneissic Terrane

-  Intrusive Rocks : para- and orthogneisses
-  Upper Unit : carbonate and quartzite
-  Middle Unit : mafic and felsic volcanics and carbonaceous sediments
-  Lower Unit : quartzite and marble

Autochthonous North American Rocks

-  Cambrian Limestones and Shales
-  Displaced Cambrian Limestones and Shales lying in and west of the Tintina Fault Zone
-  Minor Faults
-  Thrust Faults
-  Westmin/Atna: TOE property outline



WESTMIN RESOURCES LIMITED

Work By
WESTMIN
Date Drafted
Nov. 24, 1996
Drafted By
A. Turner
Date Revised

Revised By

TOE Property

Regional Geology Map

Modified after Mortensen and Jilson (1985)

N.T.S. Number
File Name
REG_GEOL.dwg



Figure

3.2

The middle package of the LMP comprises dark fine-grained strongly carbonaceous metasediments interlayered with massive to schistose felsic volcanic to tuffaceous rocks and chloritic to amphibolitic schists after mafic tuffaceous rocks. The most significant massive sulphide occurrences in the Finlayson Lake area (Wolverine, ABM/Kudz Ze Kayah, and Fire Lake) are hosted by this volcano-sedimentary package and are associated with carbonaceous metasediments and/or felsic metavolcanics.

6.0 SOIL SAMPLING

In total 180 soil samples were collected at 50 metre intervals along 200 metre spaced lines. Samples of B-horizon material were taken in all instances except where soil development was poor. In these instances, samples comprised of talus fines or other C-horizon type material. Soil sample stations were marked in the field with flagging tape and a tyvex tag with the sample number written on it. Samples were partially dried in the field and then shipped to Chemex Labs in North Vancouver, B.C. for analysis. They were subsequently dried, sieved to -80 mesh, pulverized and then analysed for 24 elements using ICP-AES and Au by fire assay-atomic absorption.

The area sampled is north of that sampled last year and mainly covers the newly staked JILL claims (see Figures 6.1-6.6). The samples were labeled with their respective grid co-ordinates (8900E – 11050N). Table 6.1 summarizes the data for the soils and assay certificates are included in Appendix E.

No significant Au or Ag anomalies were detected in the sampling. Several scattered Cu anomalies of up to 347 ppm were detected, the most interesting a two sample anomaly along the northern portion of line 9700E. Several isolated Pb anomalies of up to 300 ppm were detected, concentrated in the central portion of the grid area. Several spot anomalies of up to 824 ppm Zn and 6600

ppm Ba were also detected. No strong multi-line soil anomalies were generated from the current sampling program.

Table 6.1 Soil Geochemical Statistics

	Au ppb	Ag ppm	Cu ppm	Pb ppm	Zn ppm	Ba ppm
Minimum	2.5	0.1	9	1	14	290
Maximum	10	1.0	347	300	824	6600
Average	2.6	0.1	58	13	96	1499
Percentiles						
95 th	2.5	0.4	140	28	159	2744
90 th	2.5	0.1	98	20	138	2011
80 th	2.5	0.1	69	14	108	1682
75 th	2.5	0.1	66	13	104	1628
50 th	2.5	0.1	45	10	82	1380
10 th	2.5	0.1	22	4	49	829

7.0 GROUND GEOPHYSICS

Ground total magnetic field and horizontal loop electromagnetic field (HLEM) surveys were conducted on the TOE property. Total magnetic field surveys were conducted using a station spacing of 12.5 m and an Omni Plus proton precession magnetometer. HLEM surveys were conducted using an Apex Parametrics Maxmin I-9 with attached MMC (datalogger/computer), coil spacing of 100m, station spacing of 25 m and reading frequencies using a station spacing of 12.5 m. A copy of the geophysical report by Amerok is included in Appendix F and the associated figures are presented in Appendix G.

Amerok Geosciences Limited provided the geophysical interpretations given below.

In total 11 HLEM conductors were identified, generally conformable to mapped stratigraphy. These are compiled with the total field MAG on Figure TO-05. Most of these likely represent graphitic argillite units based on their low coincident magnetic response, high conductances, and wide response width.

Ground checking revealed that TO-4 is in fact caused by a graphitic argillite unit. Four conductors (TO-1, 5, 6, and 11) are closely associated with a positive magnetic field and have high conductances and narrow target widths and therefore merit further investigation. The southeastern portion of conductor 5 is likely one of the argillite units intersected in last years drilling in the area (Bradshaw et al., 1996). The high magnetic feature south of the conductors (see Figure TO-05) is likely caused by pyrrhotite-bearing mafic rocks observed during last years mapping program (Bradshaw et al., 1996). The remainder of the conductors on the northern part of the grid area and the western grid area could not be ground-checked due to lack of outcrop.

8.0 CONCLUSIONS AND RECOMMENDATIONS

Anomalies TO-5 and TO-1 have interesting Zn, and to a lesser extent Ba, and Cu anomalies associated with them from this years soil sampling. The 1996 soil sampling and hole TC96-01 both demonstrated that there is significant, although not concentrated, Cu and Zn mineralization associated with both argillite and carbonated mafic schist units in drill core from near anomaly TO-11.. Therefore. the area around anomaly TO-11 warrants further attention.

A reconnaissance gravity survey along gridlines where coincident soil anomalies and HLEM conductors occur is recommended as the next step in the evaluation of the TOE property. If the results of this work are favorable then targets can be prioritized and drill tested.

REFERENCES

- Aleinikoff, J.N. and Nokleberg, W.J. 1985. Age of Devonian igneous arc terranes in the northern Mount Hayes quadrangle, eastern Alaska Range, Alaska. U.S. Geological Survey Circular 967, pp. 44-49.
- Bradshaw, G.D., Terry, D.A., Turner, A.J., and Tucker, T.L. 1996. 1996 Assessment Report describing geological, geochemical, geophysical, and diamond drill hole surveys on the TOE 1-36 and JILL 1-41 Claims, Finlayson Lake area, Yukon Territory. Yukon Government assessment report.
- Foster, H.L., Keith, T.E.C., and Menzie, W.D. 1987. Geology of East-Central Alaska. U.S. Geological Survey Open-File Report 87-188m, 59 pp.
- Garrie, D.G. 1996. Dighem survey for Westmin Resources Limited, Wolverine Lake Project,
- Mortensen, J.K. 1992. Pre-Mesozoic tectonic evolution of the Yukon-Tanana terrane, Yukon and Alaska. *Tectonics*, 11(4): 836-853.
- Mortensen, J.K. and Jilson, G.A. 1985. Evolution of the Yukon-Tanana terrane: Evidence from the southeastern Yukon Territory. *Geology*, 13: 806-810.
- Nokleberg W.J. and Aleinikoff, J.N. 1985. Summary of stratigraphy, structure, and metamorphism of Devonian igneous-arc terranes, northeastern Mount Hayes quadrangle, eastern Alaska Range. U. S. Geological Survey Circular 967, pp. 66-71.
- Tempelman-Kluit, D.J. 1979. Transported cataclasite, ophiolite, and granodiorite in Yukon: evidence of arc-continent collision. *Geological Survey of Canada Paper 79-14*, 27 p.
- Tempelman-Kluit, D.J. 1977. Quiet Lake (105F) and Finlayson Lake (105G) map areas. *Geological Survey of Canada Open-File 486*, scale= 1:250,000.
- Tempelman-Kluit, D.J., Gordey, S.P., and Read, B.C. 1976. Stratigraphic and structural studies in the Pelly Mountains, Yukon Territory. *Geological Survey of Canada Paper 76-1A*, p. 97-106.

APPENDIX A
STATEMENT OF EXPENDITURES

STATEMENT OF EXPENDITURES

I, David A. Terry as agent for Westmin Resources Limited, #904-1055 Dunsmuir Street, Vancouver, B.C. do believe that a field program consisting of line-cutting, soil sampling, and ground geophysics was carried out on TOE 1-36 and JILL 1-41 between May 5 and August 30, 1997.

The following expenses were incurred during the course of this work.

Geophysical Contractors	\$10,196
Linecutting Contractors	\$14,500
Helicopter	\$11,238
Camp Costs	\$3,850
Geochemsitry	\$3,600
Permanent Salaries	\$332
Temporary Salaries	\$386
Report Preparation Costs	\$1000
Total expenditures	\$45,102

Notes:

1. Wages are based on actual man days spent on the property.
2. Helicopter charges are based on actual hours flown.
3. Assay charges are based on actual numbers of samples from the property.

And I make this solemn declaration conscientiously believing it to be true and knowing it is the same force and effect as if made under oath and by virtue of the Canadian Evidence Act.

Dated at Vancouver in the Province of British Columbia this 17 day of March, 1998

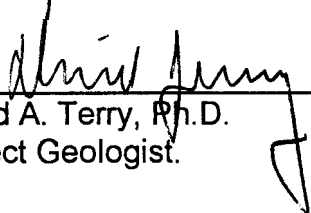

David A. Terry, Ph.D.
Project Geologist.

APPENDIX B
LIST OF CLAIMS

pref	disp n #	disposition name	Due date	Status
YB	56214	TOE 1	March 31, 2006	A
YB	56215	TOE 2	March 31, 2006	A
YB	56216	TOE 3	March 31, 2006	A
YB	56217	TOE 4	March 31, 2006	A
YB	56218	TOE 5	March 31, 2006	A
YB	56219	TOE 6	March 31, 2006	A
YB	56220	TOE 7	March 31, 2005	A
YB	56221	TOE 8	March 31, 2006	A
YB	56222	TOE 9	March 31, 2005	A
YB	56223	TOE 10	March 31, 2005	A
YB	56224	TOE 11	March 31, 2006	A
YB	56225	TOE 12	March 31, 2006	A
YB	56226	TOE 13	March 31, 2006	A
YB	56227	TOE 14	March 31, 2006	A
YB	56228	TOE 15	March 31, 2006	A
YB	56229	TOE 16	March 31, 2006	A
YB	59962	TOE 17	March 31, 2005	A
YB	59963	TOE 18	March 31, 2005	A
YB	59964	TOE 19	March 31, 2005	A
YB	59965	TOE 20	March 31, 2005	A
YB	59966	TOE 21	March 31, 2005	A
YB	59967	TOE 22	March 31, 2005	A
YB	59968	TOE 23	March 31, 2005	A
YB	59969	TOE 24	March 31, 2005	A
YB	59970	TOE 25	March 31, 2005	A
YB	59971	TOE 26	March 31, 2005	A
YB	59972	TOE 27	March 31, 2005	A
YB	59973	TOE 28	March 31, 2005	A
YB	59974	TOE 29	March 31, 2005	A
YB	59975	TOE 30	March 31, 2005	A
YB	59976	TOE 31	March 31, 2005	A
YB	59977	TOE 32	March 31, 2005	A
YB	59978	TOE 33	March 31, 2005	A
YB	59979	TOE 34	March 31, 2005	A
YB	59980	TOE 35	March 31, 2005	A
YB	59981	TOE 36	March 31, 2005	A
YB	86778	JILL 1	February 7, 2006	A
YB	86779	JILL 2	February 7, 2006	A
YB	86780	JILL 3	February 7, 2006	A
YB	86781	JILL 4	February 7, 2006	A
YB	86782	JILL 5	February 7, 2006	A
YB	86783	JILL 6	February 7, 2006	A
YB	86784	JILL 7	February 7, 2006	A
YB	86785	JILL 8	February 7, 2006	A
YB	86786	JILL 9	February 7, 2006	A
YB	86787	JILL 10	February 7, 2006	A
YB	86788	JILL 11	February 7, 2006	A
YB	86789	JILL 12	February 7, 2006	A
YB	86790	JILL 13 FR	February 7, 2006	A
YB	86791	JILL 14 FR	February 7, 2006	A
YB	86792	JILL 15 FR	February 7, 2006	A
YB	86793	JILL 16 FR	February 7, 2006	A
YB	86794	JILL 17 FR	February 7, 2006	A
YB	86795	JILL 18 FR	February 7, 2006	A
YB	86796	JILL 19	February 7, 2006	A
YB	86797	JILL 20	February 7, 2006	A
YB	86798	JILL 21	February 7, 2006	A

pref	disp'n #	disposition name	Due date	Status
YB	86799	JILL 22	February 7, 2006	A
YB	86800	JILL 23 FR	February 7, 2006	A
YB	86801	JILL 24 FR	February 7, 2006	A
YB	87468	CAP 1 FR.	September 20, 2001	A
YB	87469	LIN 1 FR.	September 20, 2001	A
YB	87470	JILL 25	September 20, 2001	A
YB	87471	JILL 26	September 20, 2001	A
YB	87472	JILL 27	September 20, 2001	A
YB	87473	JILL 28	September 20, 2001	A
YB	87474	JILL 29	September 20, 2001	A
YB	87475	JILL 30	September 20, 2001	A
YB	87476	JILL 31	September 20, 2001	A
YB	87477	JILL 32	September 20, 2001	A
YB	87478	JILL 33	September 20, 2001	A
YB	87479	JILL 34	September 20, 2001	A
YB	87480	JILL 35	September 20, 2001	A
YB	87481	JILL 36	September 20, 2001	A
YB	87482	JILL 37	September 20, 2001	A
YB	87483	JILL 38	September 20, 2001	A
YB	87484	JILL 39	September 20, 2001	A
YB	87485	JILL 40	September 20, 2001	A
YB	87486	JILL 41	September 20, 2001	A

APPENDIX C
LIST OF PERSONNEL

LIST OF PERSONNEL

David A. Terry (Project Geologist)
904-1055 Dunsmuir St.
Vancouver, B.C.
V7X 1C4

Jan Tindle (Field Assistant)
3341 Lakeside Road
Whistler, B.C.
V0N 1B3

Yvonne Thorton (Field Assistant)
3341 Lakeside Road
Whistler, B.C.
V0N 1B3

APPENDIX D
GEOLOGIST CERTIFICATE

GEOLOGIST CERTIFICATE

I, David A. Terry of 1568 Maplehurst Circle, Burnaby, in the Province of British Columbia, DO HEREBY CERTIFY:

1. THAT I am a Project Geologist with Westmin Resources Limited with offices at #904-1055 Dunsmuir Street, Vancouver, British Columbia.
2. THAT I have practiced my profession with various mining companies in Ontario, Quebec, British Columbia, Yukon, the United States, Argentina, and Chile for nine years.
3. THAT I am a graduate of the University of Western Ontario and hold a Bachelor of Science in Geology (1988) and a Doctor of Philosophy in Geology (1997).
4. THAT I am a member of the Prospectors and Developers Association of Canada, the Geological Society of America, and the Society of Economic Geologists.
5. THAT this report is based on property work I personally supervised between May 5 and August 30, 1997.
6. THAT I have no direct interest in the property described herein, nor do I expect to receive any interest.

DATED at Vancouver, British Columbia this 17 day of March, 1998.



David A. Terry, Ph.D.,
Project Geologist

APPENDIX E
ASSAY CERTIFICATES



Chemex Labs Ltd.

Analytical Chemists * Geochemists * Registered Assayers
212 Brooksbank Ave., North Vancouver
British Columbia, Canada V7J 2C1
PHONE: 604-984-0221

WESTMIN RESOURCES LTD.

P.O. BOX 49066, THE BENTALL CENTRE
VANCOUVER, BC
V7X 1C4

INVOICE NUMBER **I 9 7 3 3 7 0 8**

BILLING INFORMATION

Date: 31-JUL-97
 Project: 6410 (r0E)
 P.O. No.:
 Account: GP W

Comments: ATTN:DAVID TERRY-VANCOUVER OFFICE

Billing: For analysis performed on Certificate A9733708

Terms: Payment due on receipt of invoice
 1.25% per month (15% per annum)
 charged on overdue accounts

Please Remit Payments to:

CHEMEX LABS LTD.
 212 Brooksbank Ave.,
 North Vancouver, B.C.
 Canada V7J 2C1

COPY

# OF SAMPLES	ANALYSED FOR CODE - DESCRIPTION	UNIT PRICE	SAMPLE PRICE	AMOUNT
133	201 - Dry, sieve to -80 mesh	1.25		
	202 - save reject	0.85		
	ICP-24	10.50		
	983 - Au ppb FA+AA	9.75	22.35	2972.55
Total Cost \$				2972.55
Client Discount (25%) \$				-743.14
Net Cost \$				2229.41
(Reg# R100938885) GST \$				156.06
TOTAL PAYABLE (CDN) \$				2385.47



Chemex Labs Ltd.

Analytical Chemists * Geochemists * Registered Assayers

212 Brooksbank Ave., North Vancouver
 British Columbia, Canada V7J 2C1
 PHONE: 604-984-0221 FAX: 604-984-0218

o: WESTMIN RESOURCES LTD.
 PROJECT: WOLVERINE
 P.O. BOX 49066, THE BENTALL CENTRE
 VANCOUVER, BC
 V7X 1C4

QC P. 1-A
 Tot QC 2
 Date: 30-JUL-97
 Invoice #: 19733708
 P.O. #: GP W

Project: 6410
 Comments: ATTN:DAVID TERRY-VANCOUVER OFFICE

QC DATA OF CERTIFICATE A9733708

STD/DUP/BLANK DESCRIPTION	QC TYPE	PAGE NO.	Au ppb FA+AA	Ag ppm AAS	Al % (ICP)	Ba ppm (ICP)	Be ppm (ICP)	Bi ppm (ICP)	Ca % (ICP)	Cd ppm (ICP)	Co ppm (ICP)	Cr ppm (ICP)	Cu ppm (ICP)	Fe % (ICP)	K % (ICP)	Mg % (ICP)
ADS-1	std2	1	455	----	----	----	----	----	----	----	----	----	----	----	----	----
ADS-1	std2	2	460	----	----	----	----	----	----	----	----	----	----	----	----	----
ADS-1	std2	3	430	----	----	----	----	----	----	----	----	----	----	----	----	----
CHEMEX MEAN	---	---	470	----	----	----	----	----	----	----	----	----	----	----	----	----
BL-C	Blnk	1	< 5	----	----	----	----	----	----	----	----	----	----	----	----	----
BL-C	Blnk	2	< 5	----	----	----	----	----	----	----	----	----	----	----	----	----
BL-C	Blnk	3	< 5	----	----	----	----	----	----	----	----	----	----	----	----	----
CHEMEX MEAN	---	---	< 5	----	----	----	----	----	----	----	----	----	----	----	----	----
CR-1	std1	1	860	----	----	----	----	----	----	----	----	----	----	----	----	----
CR-1	std1	2	880	----	----	----	----	----	----	----	----	----	----	----	----	----
CR-1	std1	3	900	----	----	----	----	----	----	----	----	----	----	----	----	----
CR-1	std1	4	850	----	----	----	----	----	----	----	----	----	----	----	----	----
CHEMEX MEAN	---	---	923	----	----	----	----	----	----	----	----	----	----	----	----	----
G96-TOT	std1	1	----	----	7.95	1210	1.5	< 2	2.18	1.0	20	103	196	5.22	1.88	1.13
G96-TOT	std2	1	----	----	7.52	1090	1.0	< 2	2.02	1.5	17	91	180	4.77	1.78	1.02
G96-TOT	std1	2	----	----	8.11	1130	1.5	2	2.08	1.0	19	96	194	4.99	2.15	1.06
G96-TOT	std2	2	----	----	8.08	1090	1.5	< 2	2.07	0.5	19	94	193	4.95	1.96	1.06
G96-TOT	std1	3	----	----	8.62	1190	1.5	< 2	2.20	1.5	21	96	205	5.24	2.02	1.09
G96-TOT	std2	3	----	----	8.72	1180	1.0	2	2.21	1.5	20	98	206	5.14	1.99	1.06
CHEMEX MEAN	---	---	----	----	7.60	1135	1.1	8	2.13	0.9	17	98	177	4.60	1.82	1.00
GEO-96	std1	1	----	5.6	----	----	----	----	----	----	----	----	----	----	----	----
GEO-96	std2	1	----	5.0	----	----	----	----	----	----	----	----	----	----	----	----
GEO-96	std1	2	----	5.0	----	----	----	----	----	----	----	----	----	----	----	----
GEO-96	std2	2	----	4.8	----	----	----	----	----	----	----	----	----	----	----	----
GEO-96	std1	3	----	5.4	----	----	----	----	----	----	----	----	----	----	----	----
GEO-96	std2	3	----	5.6	----	----	----	----	----	----	----	----	----	----	----	----
GEO-96	std1	4	----	5.0	----	----	----	----	----	----	----	----	----	----	----	----
CHEMEX MEAN	---	---	----	5.6	----	----	----	----	----	----	----	----	----	----	----	----
SIO2-G2	Blnk	1	----	< 0.2	----	----	----	----	----	----	----	----	----	----	----	----
SIO2-G2	Blnk	2	----	< 0.2	----	----	----	----	----	----	----	----	----	----	----	----
SIO2-G2	Blnk	3	----	< 0.2	----	----	----	----	----	----	----	----	----	----	----	----
CHEMEX MEAN	---	---	----	< 0.2	----	----	----	----	----	----	----	----	----	----	----	----
SIO2-T4	Blnk	1	----	0.25	30	< 0.5	< 2	0.02	< 0.5	1	4	3	0.07	0.05	0.01	0.01
SIO2-T4	Blnk	2	----	0.25	30	< 0.5	< 2	0.02	< 0.5	< 1	4	3	0.07	0.05	0.01	0.01
SIO2-T4	Blnk	3	----	0.24	30	< 0.5	< 2	0.02	< 0.5	1	4	3	0.06	0.05	0.01	0.01
CHEMEX MEAN	---	---	----	0.26	30	0.5	2	0.03	1.0	1	1	3	0.07	0.05	0.01	0.01
J8900E 11050N	Dup1-01		10	< 0.2	7.21	1480	2.0	< 2	1.35	< 0.5	28	193	94	4.53	1.90	1.71
	Orig1-01		10	< 0.2	7.04	1510	2.0	< 2	1.34	< 0.5	29	184	97	4.47	1.86	1.74
J9300E 11650N	Dup2-01		< 5	< 0.2	10.50	1920	2.5	< 2	0.90	< 0.5	12	104	24	3.54	3.29	0.37

CERTIFICATION:

Hart Buchler



Chemex Labs Ltd.

Analytical Chemists * Geochemists * Registered Assayers

212 Brooksbank Ave., North Vancouver
 British Columbia, Canada V7J 2C1
 PHONE: 604-984-0221 FAX: 604-984-0218

o: WESTMIN RESOURCES LTD.
 PROJECT: WOLVERINE
 P.O. BOX 49066, THE BENTALL CENTRE
 VANCOUVER, BC
 V7X 1C4

QC Pa. 1-B
 Tot QC Pg: 2
 Date: 30-JUL-97
 Invoice #: I9733708
 P.O. #: GPW

Project: 6410
 Comments: ATTN:DAVID TERRY-VANCOUVER OFFICE

QC DATA OF CERTIFICATE A9733708

STD/DUP/BLANK DESCRIPTION	QC TYPE	PAGE NO.	Mn ppm (ICP)	Mo ppm (ICP)	Na % (ICP)	Ni ppm (ICP)	P ppm (ICP)	Pb ppm AAS	Sr ppm (ICP)	Ti % (ICP)	V ppm (ICP)	W ppm (ICP)	Zn ppm (ICP)			
ADS-1	std2	1	----	----	----	----	----	----	----	----	----	----	----			
ADS-1	std2	2	----	----	----	----	----	----	----	----	----	----	----			
ADS-1	std2	3	----	----	----	----	----	----	----	----	----	----	----			
CHEMEX MEAN	---	---	----	----	----	----	----	----	----	----	----	----	----			
BL-C	Blnk	1	----	----	----	----	----	----	----	----	----	----	----			
BL-C	Blnk	2	----	----	----	----	----	----	----	----	----	----	----			
BL-C	Blnk	3	----	----	----	----	----	----	----	----	----	----	----			
CHEMEX MEAN	---	---	----	----	----	----	----	----	----	----	----	----	----			
CR-1	std1	1	----	----	----	----	----	----	----	----	----	----	----			
CR-1	std1	2	----	----	----	----	----	----	----	----	----	----	----			
CR-1	std1	3	----	----	----	----	----	----	----	----	----	----	----			
CR-1	std1	4	----	----	----	----	----	----	----	----	----	----	----			
CHEMEX MEAN	---	---	----	----	----	----	----	----	----	----	----	----	----			
G96-TOT	std1	1	1110	8	1.04	28	640	----	263	0.35	174	10	200			
G96-TOT	std2	1	1000	8	0.98	24	570	----	239	0.32	154	< 10	176			
G96-TOT	std1	2	1030	7	1.08	27	600	----	255	0.35	162	< 10	190			
G96-TOT	std2	2	1020	7	1.08	24	590	----	257	0.33	162	< 10	184			
G96-TOT	std1	3	1075	7	1.07	28	620	----	271	0.35	170	20	202			
G96-TOT	std2	3	1070	7	1.04	29	620	----	269	0.36	167	10	200			
CHEMEX MEAN	---	---	1025	8	1.00	24	624	----	236	0.34	160	< 10	185			
GEO-96	std1	1	----	----	----	----	----	130	----	----	----	----	----			
GEO-96	std2	1	----	----	----	----	----	126	----	----	----	----	----			
GEO-96	std1	2	----	----	----	----	----	130	----	----	----	----	----			
GEO-96	std2	2	----	----	----	----	----	128	----	----	----	----	----			
GEO-96	std1	3	----	----	----	----	----	130	----	----	----	----	----			
GEO-96	std2	3	----	----	----	----	----	130	----	----	----	----	----			
GEO-96	std1	4	----	----	----	----	----	124	----	----	----	----	----			
CHEMEX MEAN	---	---	----	----	----	----	----	125	----	----	----	----	----			
SIO2-G2	Blnk	1	----	----	----	----	----	4	----	----	----	----	----			
SIO2-G2	Blnk	2	----	----	----	----	----	< 2	----	----	----	----	----			
SIO2-G2	Blnk	3	----	----	----	----	----	< 2	----	----	----	----	----			
CHEMEX MEAN	---	---	----	----	----	----	----	< 2	----	----	----	----	----			
SIO2-T4	Blnk	1	5	< 1	0.01	< 1	260	----	283	0.01	4	< 10	2			
SIO2-T4	Blnk	2	< 5	< 1	0.01	< 1	250	----	282	0.01	4	< 10	2			
SIO2-T4	Blnk	3	< 5	< 1	0.01	< 1	230	----	268	0.01	4	< 10	2			
CHEMEX MEAN	---	---	5	1	0.01	1	248	----	269	0.01	4	10	2			
J8900E 11050N	Dup1	01	570	< 1	1.03	121	1380	16	156	0.26	191	< 10	118			
	Orig1	01	575	< 1	0.99	121	1350	18	157	0.21	192	< 10	116			
J9300E 11650N	Dup2	01	210	< 1	0.99	34	420	10	268	0.17	92	< 10	72			

CERTIFICATION: David Terry



Chemex Labs Ltd.

Analytical Chemists * Geochemists * Registered Assayers
 212 Brooksbank Ave., North Vancouver
 British Columbia, Canada V7J 2C1
 PHONE: 604-984-0221 FAX: 604-984-0218

To: WESTMIN RESOURCES LTD.
 PROJECT: WOLVERINE
 P.O. BOX 49066, THE BENTALL CENTRE
 VANCOUVER, BC
 V7X 1C4

QC F 2-A
 Tot QC pg: 2
 Date: 30-JUL-97
 Invoice #: I9733708
 P.O. #: GP W

Project: 6410
 Comments: ATTN:DAVID TERRY-VANCOUVER OFFICE

QC DATA OF CERTIFICATE A9733708

STD/DUP/BLANK DESCRIPTION	QC PAGE TYPE NO.	Au ppb FA+AA	Ag ppm AAS	Al % (ICP)	Ba ppm (ICP)	Be ppm (ICP)	Bi ppm (ICP)	Ca % (ICP)	Cd ppm (ICP)	Co ppm (ICP)	Cr ppm (ICP)	Cu ppm (ICP)	Fe % (ICP)	K % (ICP)	Mg % (ICP)
J9500E 12200N	Orig2-01	< 5	< 0.2	10.25	1940	2.5	< 2	0.90	0.5	13	104	24	3.57	3.22	0.37
	Dup3-01	< 5	< 0.2	7.45	1620	1.5	< 2	0.24	< 0.5	27	88	55	7.02	2.02	1.39
	Orig3-01	< 5	< 0.2	7.31	1580	1.5	< 2	0.24	< 0.5	27	94	55	6.96	2.04	1.45

CERTIFICATION: David Terry

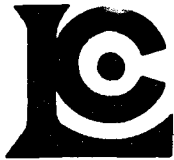

Chemex Labs Ltd.

Analytical Chemists * Geochemists * Registered Assayers
212 Brooksbank Ave., North Vancouver
British Columbia, Canada V7J 2C1
PHONE: 604-984-0221 FAX: 604-984-0218

o: WESTMIN RESOURCES LTD.
PROJECT: WOLVERINE
P.O. BOX 49066, THE BENTALL CENTRE
VANCOUVER, BC
V7X 1C4

QC Pa 2-B
Tot QC Pg: 2
Date: 30-JUL-97
Invoice #: 19733708
P.O. #: GPW

Project: 6410
Comments: ATTN:DAVID TERRY-VANCOUVER OFFICE

QC DATA OF CERTIFICATE A9733708

STD/DUP/BLANK DESCRIPTION	QC PAGE TYPE NO.	Mn ppm (ICP)	Mo ppm (ICP)	Na % (ICP)	Ni ppm (ICP)	P ppm (ICP)	Pb ppm AAS	Sr ppm (ICP)	Ti % (ICP)	V ppm (ICP)	W ppm (ICP)	Zn ppm (ICP)			
J9500E 12200N	Orig2-01	210	< 1	0.98	34	410	8	261	0.15	92	< 10	72			
	Dup3-01	830	2	0.72	46	610	28	73	0.55	219	< 10	96			
	Orig3-01	840	< 1	0.75	47	620	26	74	0.59	220	< 10	94			

CERTIFICATION: Hart Bickler



Chemex Labs Ltd.

Analytical Chemists * Geochemists * Registered Assayers

212 Brooksbank Ave., North Vancouver
 British Columbia, Canada V7J 2C1
 PHONE: 604-984-0221 FAX: 604-984-0218

o: WESTMIN RESOURCES LTD.
 PROJECT: WOLVERINE
 P.O. BOX 49066, THE BENTALL CENTRE
 VANCOUVER, BC
 V7X 1C4

A9733708

Comments: ATTN:DAVID TERRY-VANCOUVER OFFICE

CERTIFICATE

A9733708

(GP W) - WESTMIN RESOURCES LTD.

Project: 6410
 P.O. #:

Samples submitted to our lab in Vancouver, BC.
 This report was printed on 30-JUL-97.

SAMPLE PREPARATION

CHEMEX CODE	NUMBER SAMPLES	DESCRIPTION
201	133	Dry, sieve to -80 mesh
202	133	save reject
285	133	ICP - HF digestion charge

ANALYTICAL PROCEDURES

CHEMEX CODE	NUMBER SAMPLES	DESCRIPTION	METHOD	DETECTION LIMIT	UPPER LIMIT
983	133	Au ppb: Fuse 30 g sample	FA-AAS	5	10000
578	133	Ag ppm: 24 element, rock & core	AAS	0.2	100.0
573	133	Al %: 24 element, rock & core	ICP-AES	0.01	25.0
565	133	Ba ppm: 24 element, rock & core	ICP-AES	10	10000
575	133	Be ppm: 24 element, rock & core	ICP-AES	0.5	1000
561	133	Bi ppm: 24 element, rock & core	ICP-AES	2	10000
576	133	Ca %: 24 element, rock & core	ICP-AES	0.01	25.0
562	133	Cd ppm: 24 element, rock & core	ICP-AES	0.5	500
563	133	Co ppm: 24 element, rock & core	ICP-AES	1	10000
569	133	Cr ppm: 24 element, rock & core	ICP-AES	1	10000
577	133	Cu ppm: 24 element, rock & core	ICP-AES	1	10000
566	133	Fe %: 24 element, rock & core	ICP-AES	0.01	25.0
584	133	K %: 24 element, rock & core	ICP-AES	0.01	10.00
570	133	Mg %: 24 element, rock & core	ICP-AES	0.01	15.00
568	133	Mn ppm: 24 element, rock & core	ICP-AES	5	10000
554	133	Mo ppm: 24 element, rock & core	ICP-AES	1	10000
583	133	Na %: 24 element, rock & core	ICP-AES	0.01	10.00
564	133	Ni ppm: 24 element, rock & core	ICP-AES	1	10000
559	133	P ppm: 24 element, rock & core	ICP-AES	10	10000
560	133	Pb ppm: 24 element, rock & core	AAS	2	10000
582	133	Sr ppm: 24 element, rock & core	ICP-AES	1	10000
579	133	Ti %: 24 element, rock & core	ICP-AES	0.01	10.00
572	133	V ppm: 24 element, rock & core	ICP-AES	1	10000
556	133	W ppm: 24 element, rock & core	ICP-AES	10	10000
558	133	Zn ppm: 24 element, rock & core	ICP-AES	2	10000



Chemex Labs Ltd.

Analytical Chemists * Geochemists * Registered Assayers

212 Brooksbank Ave., North Vancouver
British Columbia, Canada V7J 2C1
PHONE: 604-984-0221 FAX: 604-984-0218

Client: WESTMIN RESOURCES LTD.
PROJECT: WOLVERINE
P.O. BOX 49066, THE BENTALL CENTRE
VANCOUVER, BC
V7X 1C4

Project: 6410
Comments: ATTN:DAVID TERRY-VANCOUVER OFFICE

Page: 1 of 1-A
Total Pages: 4
Certificate Date: 30-JUL-97
Invoice No.: 19733708
P.O. Number:
Account: GPW

CERTIFICATE OF ANALYSIS A9733708

SAMPLE	PREP CODE	Au ppb FA+AA	Ag ppm AAS	Al % (ICP)	Ba ppm (ICP)	Be ppm (ICP)	Bi ppm (ICP)	Ca % (ICP)	Cd ppm (ICP)	Co ppm (ICP)	Cr ppm (ICP)	Cu ppm (ICP)	Fe % (ICP)	K % (ICP)	Mg % (ICP)
J8900E 11050N	201 202	10	< 0.2	7.04	1510	2.0	< 2	1.34	< 0.5	29	184	97	4.47	1.86	1.74
J8900E 11100N	201 202	10	< 0.2	6.68	1400	1.5	< 2	1.55	1.5	53	175	106	5.25	1.62	1.53
J8900E 11150N	201 202	< 5	< 0.2	5.43	700	1.0	< 2	2.47	0.5	8	30	52	1.70	1.48	0.79
J8900E 11200N	201 202	< 5	< 0.2	3.73	670	0.5	< 2	3.52	0.5	12	62	56	1.83	0.96	0.92
J8900E 11250N	201 202	< 5	< 0.2	6.66	1420	1.5	< 2	1.65	< 0.5	21	143	64	3.95	1.63	1.35
J8900E 11350N	201 202	< 5	< 0.2	5.49	660	0.5	< 2	3.35	0.5	7	21	43	1.66	1.40	0.75
J8900E 11400N	201 202	< 5	< 0.2	2.45	290	0.5	< 2	4.15	0.5	7	22	85	1.17	0.44	0.54
J8900E 11450N	201 202	5	< 0.2	6.36	1210	2.0	< 2	2.01	< 0.5	37	149	106	5.75	1.54	0.90
J8900E 11500N	201 202	< 5	1.0	5.45	1030	2.0	< 2	1.54	< 0.5	17	118	34	3.17	1.48	1.06
J8900E 11550N	201 202	< 5	0.4	3.20	670	0.5	< 2	3.46	< 0.5	13	39	67	2.61	0.88	0.54
J8900E 11600N	201 202	< 5	< 0.2	3.79	680	0.5	< 2	3.36	0.5	4	12	26	1.54	1.03	0.48
J8900E 11650N	201 202	< 5	< 0.2	4.93	1020	1.0	< 2	3.23	< 0.5	16	42	257	2.29	1.35	0.71
J8900E 11700N	201 202	< 5	< 0.2	5.40	1160	1.5	< 2	2.44	< 0.5	31	52	106	5.43	1.07	1.01
J8900E 11750N	201 202	< 5	< 0.2	7.74	1620	1.5	< 2	0.48	0.5	26	105	72	6.00	1.72	0.99
J8900E 11800N	201 202	< 5	< 0.2	7.85	1110	1.5	< 2	1.60	0.5	11	50	25	3.62	2.34	0.43
J9100E 11150N	201 202	< 5	< 0.2	5.96	1490	2.0	< 2	1.24	< 0.5	21	190	44	3.59	2.02	1.30
J9100E 11200N	201 202	< 5	< 0.2	7.00	1470	2.0	< 2	1.27	< 0.5	25	161	96	5.27	1.62	1.66
J9100E 11250N	201 202	< 5	< 0.2	4.83	580	0.5	< 2	3.01	< 0.5	4	8	21	1.28	1.27	0.65
J9100E 11300N	201 202	< 5	< 0.2	6.02	1010	2.0	< 2	1.50	0.5	13	81	17	2.74	1.78	0.97
J9100E 11350N	201 202	< 5	0.4	5.40	1030	2.0	< 2	1.38	1.5	12	112	45	3.04	1.59	1.12
J9100E 11400N	201 202	< 5	< 0.2	5.15	1010	2.0	< 2	1.03	1.0	12	98	25	2.44	1.50	0.91
J9100E 11450N	201 202	< 5	< 0.2	9.61	1570	2.0	< 2	0.53	2.5	30	102	163	9.07	1.64	0.55
J9100E 11500N	201 202	< 5	< 0.2	7.26	1420	2.0	< 2	1.07	0.5	26	76	36	4.25	1.68	0.75
J9100E 11550N	201 202	< 5	< 0.2	3.89	700	0.5	< 2	3.52	0.5	13	18	48	2.14	0.95	0.58
J9100E 11600N	201 202	< 5	< 0.2	7.61	1770	1.5	< 2	1.22	0.5	17	84	64	3.46	2.61	0.65
J9100E 11650N	201 202	< 5	< 0.2	8.23	2210	2.0	< 2	0.63	< 0.5	16	95	44	4.34	2.57	0.87
J9100E 11700N	201 202	< 5	< 0.2	10.20	1490	2.0	< 2	0.68	0.5	7	91	14	2.56	2.84	0.36
J9100E 11750N	201 202	< 5	< 0.2	7.76	4120	3.0	< 2	0.68	0.5	19	93	69	5.92	2.42	0.55
J9300E 11050N	201 202	< 5	< 0.2	5.98	1430	2.0	< 2	1.28	0.5	17	159	54	3.58	1.71	1.55
J9300E 11100N	201 202	< 5	< 0.2	6.94	1650	2.0	< 2	1.46	0.5	33	266	93	6.30	1.85	1.61
J9300E 11150N	201 202	< 5	< 0.2	5.14	1040	2.0	< 2	1.16	< 0.5	9	114	26	2.33	1.56	1.06
J9300E 11200N	201 202	< 5	< 0.2	5.77	960	2.5	< 2	1.09	< 0.5	11	98	18	2.69	1.86	1.06
J9300E 11250N	201 202	< 5	< 0.2	7.41	850	1.0	< 2	2.02	< 0.5	4	6	20	1.55	2.15	0.56
J9300E 11300N	201 202	< 5	< 0.2	5.83	1000	1.5	< 2	1.48	< 0.5	10	76	34	2.42	1.63	0.91
J9300E 11350N	201 202	< 5	< 0.2	9.31	3650	2.5	2	1.37	< 0.5	18	106	45	4.12	3.68	0.63
J9300E 11400N	201 202	< 5	< 0.2	5.17	700	0.5	< 2	2.85	1.0	5	12	23	1.33	1.42	0.52
J9300E 11450N	201 202	< 5	< 0.2	9.82	3270	2.5	< 2	0.27	1.5	16	100	19	3.87	3.77	0.41
J9300E 11500N	201 202	< 5	< 0.2	10.60	2710	2.5	< 2	0.39	< 0.5	17	106	19	3.40	4.07	0.66
J9300E 11550N	201 202	< 5	< 0.2	9.79	2570	2.0	< 2	0.26	0.5	17	106	45	4.41	4.18	0.77
J9300E 11600N	201 202	< 5	< 0.2	8.21	810	1.0	< 2	0.75	< 0.5	15	30	25	5.94	0.83	0.42

CERTIFICATION: Hart Buchler



Chemex Labs Ltd.

Analytical Chemists * Geochemists * Registered Assayers

212 Brooksbank Ave., North Vancouver
British Columbia, Canada V7J 2C1
PHONE: 604-984-0221 FAX: 604-984-0218

to: WESTMIN RESOURCES LTD.
PROJECT: WOLVERINE
P.O. BOX 49066, THE BENTALL CENTRE
VANCOUVER, BC
V7X 1C4

Project: 6410
Comments: ATTN:DAVID TERRY-VANCOUVER OFFICE

Page: 1-B
Total Pages: 4
Certificate Date: 30-JUL-97
Invoice No.: I9733708
P.O. Number:
Account: GP W

CERTIFICATE OF ANALYSIS A9733708

SAMPLE	PREP CODE	Mn ppm (ICP)	Mo ppm (ICP)	Na % (ICP)	Ni ppm (ICP)	P ppm (ICP)	Pb ppm AAS	Sr ppm (ICP)	Ti % (ICP)	V ppm (ICP)	W ppm (ICP)	Zn ppm (ICP)			
J8900E 11050N	201 202	575	< 1	0.99	121	1350	18	157	0.21	192	< 10	116			
J8900E 11100N	201 202	2270	1	0.97	145	1550	10	181	0.22	189	< 10	120			
J8900E 11150N	201 202	300	1	1.84	37	660	4	415	0.16	51	< 10	52			
J8900E 11200N	201 202	425	< 1	0.72	56	1220	8	224	0.13	76	< 10	94			
J8900E 11250N	201 202	470	< 1	1.09	83	1220	12	183	0.24	156	< 10	74			
J8900E 11350N	201 202	360	< 1	1.81	26	940	4	445	0.15	55	< 10	44			
J8900E 11400N	201 202	660	1	0.42	62	930	< 2	230	0.06	33	< 10	14			
J8900E 11450N	201 202	1495	9	0.65	95	1590	4	192	0.18	168	< 10	54			
J8900E 11500N	201 202	600	1	1.04	50	1270	14	126	0.25	152	< 10	64			
J8900E 11550N	201 202	720	< 1	0.49	45	1110	6	193	0.09	89	< 10	72			
J8900E 11600N	201 202	275	< 1	1.14	11	780	6	332	0.11	29	< 10	36			
J8900E 11650N	201 202	380	< 1	1.01	60	1070	4	302	0.12	77	< 10	52			
J8900E 11700N	201 202	2030	< 1	1.05	69	2260	6	150	0.26	152	< 10	88			
J8900E 11750N	201 202	595	< 1	1.15	51	410	10	113	0.29	256	< 10	108			
J8900E 11800N	201 202	815	< 1	1.72	24	790	36	235	0.13	60	< 10	92			
J9100E 11150N	201 202	750	< 1	1.03	102	1290	20	124	0.25	127	< 10	104			
J9100E 11200N	201 202	525	1	0.96	115	1040	6	168	0.33	187	< 10	60			
J9100E 11250N	201 202	305	< 1	1.83	11	710	< 2	428	0.14	33	< 10	44			
J9100E 11300N	201 202	680	2	1.44	32	860	12	179	0.27	95	< 10	64			
J9100E 11350N	201 202	565	1	1.05	65	1220	10	131	0.23	147	< 10	82			
J9100E 11400N	201 202	350	< 1	1.07	42	1440	10	136	0.25	182	< 10	76			
J9100E 11450N	201 202	610	16	0.48	118	3270	20	123	0.22	651	< 10	216			
J9100E 11500N	201 202	1535	1	1.14	33	700	40	199	0.25	143	< 10	142			
J9100E 11550N	201 202	1100	< 1	1.02	22	1310	4	273	0.14	62	< 10	48			
J9100E 11600N	201 202	535	3	1.10	43	610	18	191	0.23	138	< 10	152			
J9100E 11650N	201 202	340	< 1	0.90	41	420	12	111	0.24	171	< 10	86			
J9100E 11700N	201 202	175	< 1	1.26	16	440	4	284	0.20	98	< 10	50			
J9100E 11750N	201 202	1035	8	0.83	65	780	28	128	0.29	556	< 10	82			
J9300E 11050N	201 202	540	2	1.05	85	1050	58	118	0.29	136	< 10	104			
J9300E 11100N	201 202	855	2	0.80	151	1430	10	134	0.24	201	< 10	96			
J9300E 11150N	201 202	335	2	1.16	50	1660	8	127	0.24	180	< 10	62			
J9300E 11200N	201 202	480	< 1	1.34	45	890	10	126	0.29	120	< 10	76			
J9300E 11250N	201 202	365	< 1	3.02	6	520	4	598	0.18	33	< 10	50			
J9300E 11300N	201 202	370	< 1	1.39	46	750	6	240	0.23	119	< 10	66			
J9300E 11350N	201 202	715	< 1	0.50	50	870	6	75	0.25	116	< 10	98			
J9300E 11400N	201 202	300	< 1	1.80	10	700	6	414	0.15	50	< 10	48			
J9300E 11450N	201 202	585	< 1	0.44	32	340	300	71	0.21	93	< 10	156			
J9300E 11500N	201 202	360	< 1	0.53	29	230	6	72	0.25	160	< 10	86			
J9300E 11550N	201 202	280	< 1	0.47	48	170	8	49	0.23	141	< 10	84			
J9300E 11600N	201 202	385	< 1	1.71	10	1700	10	167	0.31	167	< 10	70			

CERTIFICATION:

Hart Buchler

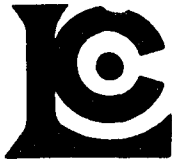

Chemex Labs Ltd.

Analytical Chemists * Geochemists * Registered Assayers
 212 Brooksbank Ave., North Vancouver
 British Columbia, Canada V7J 2C1
 PHONE: 604-984-0221 FAX: 604-984-0218

to: WESTMIN RESOURCES LTD.
 PROJECT: WOLVERINE
 P.O. BOX 49066, THE BENTALL CENTRE
 VANCOUVER, BC
 V7X 1C4

Page 1 of 2-A
 Total Pages : 4
 Certificate Date: 30-JUL-97
 Invoice No. : I9733708
 P.O. Number :
 Account : GPW

Project : 6410
 Comments: ATTN:DAVID TERRY-VANCOUVER OFFICE

CERTIFICATE OF ANALYSIS A9733708

SAMPLE	PREP CODE	Au ppb FA+AA	Ag ppm AAS	Al % (ICP)	Ba ppm (ICP)	Be ppm (ICP)	Bi ppm (ICP)	Ca % (ICP)	Cd ppm (ICP)	Co ppm (ICP)	Cr ppm (ICP)	Cu ppm (ICP)	Fe % (ICP)	K % (ICP)	Mg % (ICP)
J9300E 11650N	201 202	< 5	< 0.2	10.25	1940	2.5	< 2	0.90	0.5	13	104	24	3.57	3.22	0.37
J9300E 11700N	201 202	< 5	< 0.2	7.66	1540	1.5	< 2	0.85	< 0.5	10	79	20	3.20	2.18	0.72
J9300E 11750N	201 202	< 5	< 0.2	8.77	1650	2.0	< 2	0.55	< 0.5	22	63	39	6.67	2.56	1.07
J9300E 11800N	201 202	< 5	< 0.2	7.29	1690	1.5	< 2	2.14	0.5	24	52	57	3.69	1.45	1.07
J9300E 11850N	201 202	< 5	< 0.2	7.24	1290	1.5	< 2	0.74	< 0.5	11	88	19	3.52	1.48	0.95
J9300E 11900N	201 202	< 5	< 0.2	8.10	1930	2.0	< 2	0.62	0.5	7	70	38	2.35	2.64	0.49
J9300E 11950N	201 202	< 5	< 0.2	7.06	1580	2.0	< 2	0.36	< 0.5	13	98	29	4.15	1.89	0.96
J9300E 12000N	201 202	< 5	< 0.2	6.39	1590	2.0	2	0.65	< 0.5	19	85	58	4.43	1.59	1.04
J9300E 12050N	201 202	< 5	< 0.2	7.03	1890	1.5	< 2	0.68	1.0	22	68	43	4.87	1.70	0.93
J9300E 12100N	201 202	< 5	< 0.2	6.24	1300	1.5	< 2	0.39	< 0.5	11	117	17	3.92	1.47	1.18
J9300E 12150N	201 202	< 5	< 0.2	6.70	1430	1.5	< 2	0.41	< 0.5	11	168	22	4.20	1.74	1.04
J9300E 12200N	201 202	< 5	< 0.2	6.27	1180	1.5	< 2	0.47	< 0.5	13	80	28	4.15	1.72	0.90
J9300E 12250N	201 202	< 5	< 0.2	2.59	430	0.5	< 2	3.50	< 0.5	9	17	59	1.73	0.66	0.59
J9300E 12300N	201 202	< 5	< 0.2	6.85	1300	2.0	2	0.37	< 0.5	18	104	45	4.86	1.77	1.18
J9300E 12350N	201 202	< 5	< 0.2	4.98	1310	1.5	< 2	2.52	< 0.5	24	67	108	4.42	1.36	1.13
J9300E 12400N	201 202	< 5	< 0.2	7.31	980	1.5	< 2	2.14	< 0.5	7	25	36	2.14	2.07	0.71
J9300E 12450N	201 202	< 5	< 0.2	6.52	1390	1.5	< 2	1.68	< 0.5	18	82	59	3.96	1.78	1.13
J9500E 11050N	201 202	< 5	< 0.2	6.55	910	3.0	< 2	1.32	< 0.5	11	85	20	2.64	2.13	1.09
J9500E 11100N	201 202	< 5	< 0.2	7.71	2020	2.0	< 2	1.34	< 0.5	39	274	104	5.18	1.81	2.05
J9500E 11150N	201 202	< 5	< 0.2	7.59	1070	1.5	< 2	1.45	< 0.5	22	59	54	4.77	1.79	0.65
J9500E 11200N	201 202	< 5	< 0.2	6.14	1160	1.5	< 2	1.68	0.5	12	99	41	2.55	1.87	0.85
J9500E 11250N	201 202	< 5	< 0.2	1.49	450	0.5	< 2	4.73	0.5	6	26	64	1.39	0.33	0.49
J9500E 11300N	201 202	< 5	< 0.2	7.74	2540	2.0	< 2	1.50	0.5	24	143	95	4.96	2.45	1.41
J9500E 11350N	201 202	< 5	< 0.2	10.50	3440	3.0	< 2	0.52	< 0.5	15	102	53	5.23	4.47	0.51
J9500E 11400N	201 202	< 5	< 0.2	7.01	1240	1.5	< 2	1.04	< 0.5	12	54	24	3.05	2.11	0.78
J9500E 11450N	201 202	< 5	< 0.2	8.19	1660	2.0	< 2	0.61	0.5	11	98	14	3.23	2.53	0.89
J9500E 11500N	201 202	< 5	< 0.2	11.90	4590	3.5	< 2	0.86	1.0	20	116	84	3.33	5.60	1.19
J9500E 11550N	201 202	< 5	< 0.2	7.49	1770	2.0	< 2	0.71	0.5	8	80	69	2.65	2.67	0.64
J9500E 11600N	201 202	< 5	< 0.2	7.65	1400	2.0	< 2	0.64	0.5	6	64	16	2.12	3.09	0.52
J9500E 11650N	201 202	< 5	< 0.2	8.38	1530	2.0	< 2	1.37	2.5	10	49	34	2.66	2.62	0.54
J9500E 11700N	201 202	< 5	< 0.2	8.85	1610	2.0	< 2	0.80	< 0.5	22	82	41	4.44	3.04	0.44
J9500E 11750N	201 202	< 5	< 0.2	7.69	2090	2.0	< 2	11.00	0.5	9	66	21	2.69	3.35	0.85
J9500E 11800N	201 202	< 5	< 0.2	7.59	1340	2.0	< 2	0.79	< 0.5	12	78	18	3.47	2.06	1.01
J9500E 11850N	201 202	< 5	< 0.2	3.96	830	0.5	< 2	2.02	< 0.5	9	48	73	2.27	1.69	0.48
J9500E 11900N	201 202	< 5	< 0.2	2.49	600	0.5	< 2	3.27	1.5	8	19	180	1.28	0.64	0.66
J9500E 11950N	201 202	< 5	< 0.2	3.89	810	0.5	< 2	3.34	0.5	25	132	93	3.74	0.78	1.73
J9500E 12000N	201 202	< 5	< 0.2	6.13	880	1.0	< 2	2.25	< 0.5	35	55	139	5.62	1.46	1.31
J9500E 12050N	201 202	< 5	< 0.2	7.50	1240	1.5	< 2	0.60	< 0.5	31	124	43	6.60	1.86	1.51
J9500E 12100N	201 202	< 5	< 0.2	7.11	1310	1.5	< 2	0.50	< 0.5	24	107	38	4.59	1.68	1.09
J9500E 12150N	201 202	< 5	< 0.2	6.84	1280	2.0	< 2	0.41	< 0.5	20	79	58	5.96	1.81	1.55

CERTIFICATION: *Hart Becker*



Chemex Labs Ltd.

Analytical Chemists * Geochemists * Registered Assayers

212 Brooksbank Ave., North Vancouver
 British Columbia, Canada V7J 2C1
 PHONE: 604-984-0221 FAX: 604-984-0218

WESTMIN RESOURCES LTD.
 PROJECT: WOLVERINE
 P.O. BOX 49066, THE BENTALL CENTRE
 VANCOUVER, BC
 V7X 1C4

Project: 6410
 Comments: ATTN:DAVID TERRY-VANCOUVER OFFICE

Page 1 of 2-B
 Total Pages : 4
 Certificate Date: 30-JUL-97
 Invoice No. : 19733708
 P.O. Number :
 Account : GP W

CERTIFICATE OF ANALYSIS A9733708

SAMPLE	PREP CODE	Mn ppm (ICP)	Mo ppm (ICP)	Na % (ICP)	Ni ppm (ICP)	P ppm (ICP)	Pb ppm AAS	Sr ppm (ICP)	Ti % (ICP)	V ppm (ICP)	W ppm (ICP)	Zn ppm (ICP)			
J9300E 11650N	201 202	210	< 1	0.98	34	410	8	261	0.15	92	< 10	72			
J9300E 11700N	201 202	385	< 1	1.43	30	300	14	208	0.29	124	< 10	58			
J9300E 11750N	201 202	680	< 1	0.74	34	640	12	95	0.29	253	< 10	106			
J9300E 11800N	201 202	1540	< 1	1.67	27	1180	14	288	0.31	119	< 10	82			
J9300E 11850N	201 202	420	< 1	1.51	34	260	20	122	0.29	139	< 10	156			
J9300E 11900N	201 202	200	8	1.15	25	550	14	201	0.29	335	< 10	66			
J9300E 11950N	201 202	320	1	0.87	44	270	12	80	0.42	180	< 10	70			
J9300E 12000N	201 202	730	2	0.96	48	1170	14	114	0.42	188	< 10	76			
J9300E 12050N	201 202	1435	3	1.50	33	620	12	182	0.66	193	< 10	102			
J9300E 12100N	201 202	270	< 1	1.16	35	450	10	79	0.55	195	< 10	52			
J9300E 12150N	201 202	300	< 1	0.87	51	270	12	83	0.45	211	< 10	42			
J9300E 12200N	201 202	320	1	0.98	34	650	10	90	0.40	177	< 10	52			
J9300E 12250N	201 202	540	< 1	0.53	23	1080	4	243	0.08	59	< 10	30			
J9300E 12300N	201 202	515	3	0.87	54	430	12	84	0.35	202	< 10	74			
J9300E 12350N	201 202	1195	1	0.45	55	1450	12	161	0.27	154	< 10	74			
J9300E 12400N	201 202	420	< 1	2.37	19	500	6	515	0.19	62	< 10	62			
J9300E 12450N	201 202	840	< 1	1.04	49	1280	8	209	0.23	150	< 10	92			
J9500E 11050N	201 202	565	< 1	1.52	44	620	18	155	0.31	89	< 10	74			
J9500E 11100N	201 202	725	1	0.69	187	1540	12	126	0.22	213	< 10	102			
J9500E 11150N	201 202	545	3	1.19	67	1050	6	221	0.21	145	< 10	62			
J9500E 11200N	201 202	525	< 1	1.42	51	950	12	268	0.21	130	< 10	62			
J9500E 11250N	201 202	525	< 1	0.10	51	1320	8	203	0.05	39	< 10	24			
J9500E 11300N	201 202	615	< 1	0.77	94	1480	28	139	0.24	285	< 10	182			
J9500E 11350N	201 202	680	< 1	0.49	45	630	16	108	0.17	198	< 10	70			
J9500E 11400N	201 202	605	< 1	1.86	31	290	10	329	0.21	99	< 10	56			
J9500E 11450N	201 202	330	< 1	1.05	26	220	66	111	0.33	140	< 10	82			
J9500E 11500N	201 202	420	1	0.42	57	680	28	67	0.26	204	10	72			
J9500E 11550N	201 202	215	14	1.06	42	1280	22	136	0.32	396	10	100			
J9500E 11600N	201 202	355	8	0.98	25	950	10	173	0.22	522	10	92			
J9500E 11650N	201 202	380	< 1	1.31	15	480	156	286	0.16	78	10	198			
J9500E 11700N	201 202	630	< 1	0.79	52	460	30	193	0.13	98	< 10	104			
J9500E 11750N	201 202	370	< 1	0.26	23	490	6	196	0.16	64	< 10	72			
J9500E 11800N	201 202	290	< 1	1.11	31	350	12	114	0.30	122	< 10	62			
J9500E 11850N	201 202	330	< 1	0.21	28	850	< 2	126	0.11	99	< 10	14			
J9500E 11900N	201 202	700	< 1	0.40	20	1510	< 2	269	0.08	46	< 10	54			
J9500E 11950N	201 202	925	< 1	0.60	119	1180	6	334	0.29	107	< 10	54			
J9500E 12000N	201 202	1135	1	1.16	89	1220	< 2	243	0.17	241	< 10	48			
J9500E 12050N	201 202	1085	< 1	1.02	70	990	8	104	0.31	208	< 10	86			
J9500E 12100N	201 202	1210	< 1	0.98	43	510	6	108	0.33	190	< 10	84			
J9500E 12150N	201 202	800	1	0.84	46	830	18	102	0.49	223	< 10	90			

CERTIFICATION:

David Buchler



Chemex Labs Ltd.

Analytical Chemists * Geochemists * Registered Assayers

212 Brooksbank Ave., North Vancouver
 British Columbia, Canada V7J 2C1
 PHONE: 604-984-0221 FAX: 604-984-0218

o: WESTMIN RESOURCES LTD.
 PROJECT: WOLVERINE
 P.O. BOX 49066, THE BENTALL CENTRE
 VANCOUVER, BC
 V7X 1C4

Page : ar :3-A
 Total Pages :4
 Certificate Date: 30-JUL-97
 Invoice No. :I9733708
 P.O. Number :
 Account :GP W

Project : 6410
 Comments: ATTN:DAVID TERRY-VANCOUVER OFFICE

CERTIFICATE OF ANALYSIS A9733708

SAMPLE	PREP CODE	Au ppb FA+AA	Ag ppm AAS	Al % (ICP)	Ba ppm (ICP)	Be ppm (ICP)	Bi ppm (ICP)	Ca % (ICP)	Cd ppm (ICP)	Co ppm (ICP)	Cr ppm (ICP)	Cu ppm (ICP)	Fe % (ICP)	K % (ICP)	Mg % (ICP)
J9500E 12200N	201 202	< 5	< 0.2	7.31	1580	1.5	< 2	0.24	< 0.5	27	94	55	6.96	2.04	1.45
J9500E 12250N	201 202	< 5	< 0.2	7.10	1860	1.5	< 2	0.51	< 0.5	23	75	64	6.50	2.00	1.26
J9500E 12300N	201 202	< 5	< 0.2	6.16	1300	1.5	< 2	2.00	0.5	14	57	39	3.39	1.88	0.79
J9500E 12350N	201 202	< 5	< 0.2	7.76	1800	2.0	< 2	0.68	< 0.5	20	114	67	4.46	2.44	1.14
J9500E 12400N	201 202	< 5	< 0.2	8.08	1690	2.0	< 2	0.82	< 0.5	17	112	53	4.11	2.59	1.07
J9700E 11000N	201 202	< 5	< 0.2	6.37	1080	2.5	< 2	1.07	< 0.5	10	89	20	2.72	1.97	1.25
J9700E 11050N	201 202	< 5	0.4	7.24	1210	2.0	< 2	0.93	1.5	25	114	53	3.77	1.82	0.92
J9700E 11100N	201 202	< 5	< 0.2	9.92	5830	2.5	2	0.56	2.0	16	157	67	3.63	3.97	1.21
J9700E 11150N	201 202	< 5	< 0.2	9.98	6600	2.5	< 2	1.37	1.5	18	102	65	5.19	3.90	1.27
J9700E 11200N	201 202	< 5	< 0.2	5.72	1010	1.5	< 2	1.85	< 0.5	14	86	36	3.15	1.42	1.03
J9700E 11250N	201 202	< 5	< 0.2	9.29	3000	2.5	2	0.64	0.5	21	99	176	5.41	3.48	0.59
J9700E 11300N	201 202	< 5	< 0.2	7.28	1450	2.0	< 2	0.91	< 0.5	21	92	36	4.11	2.04	0.99
J9700E 11350N	201 202	< 5	< 0.2	5.51	2680	1.5	< 2	1.01	1.0	14	72	43	2.89	1.82	0.60
J9700E 11400N	201 202	< 5	< 0.2	6.00	1140	1.5	< 2	2.45	0.5	12	62	50	2.49	1.75	0.89
J9700E 11450N	201 202	< 5	< 0.2	7.21	1580	2.0	< 2	1.03	0.5	19	124	68	4.41	2.11	1.41
J9700E 11500N	201 202	< 5	< 0.2	13.25	2010	2.5	< 2	3.38	3.0	48	97	195	9.82	2.89	2.23
J9700E 11550N	201 202	< 5	< 0.2	6.55	1130	1.5	< 2	2.59	3.0	9	53	40	2.29	1.92	0.97
J9700E 11600N	201 202	< 5	< 0.2	6.91	1660	1.5	< 2	1.23	0.5	24	159	65	4.51	1.89	2.05
J9700E 11650N	201 202	< 5	< 0.2	8.36	1700	2.0	< 2	5.84	< 0.5	16	83	39	4.03	2.84	1.17
J9700E 11700N	201 202	< 5	< 0.2	7.16	1990	1.5	< 2	1.12	1.0	22	133	88	4.84	2.19	1.31
J9700E 11750N	201 202	< 5	< 0.2	6.05	1150	1.5	< 2	1.49	0.5	19	116	121	3.72	1.57	1.53
J9700E 11800N	201 202	< 5	< 0.2	5.35	1230	1.5	< 2	1.57	< 0.5	16	98	83	2.83	1.56	1.22
J9700E 11850N	201 202	< 5	< 0.2	4.09	1270	1.0	< 2	2.50	1.5	51	21	131	14.20	1.41	0.70
J9700E 11900N	201 202	< 5	< 0.2	7.76	1540	2.0	< 2	0.53	< 0.5	25	133	65	5.78	1.96	1.20
J9700E 11950N	201 202	< 5	< 0.2	7.77	1680	2.0	< 2	0.90	< 0.5	13	87	24	4.64	2.23	0.90
J9700E 12000N	201 202	< 5	< 0.2	4.49	580	0.5	< 2	2.82	0.5	10	26	45	2.17	1.25	0.62
J9700E 12050N	201 202	< 5	< 0.2	9.28	1840	1.5	< 2	0.71	0.5	29	52	161	8.51	2.43	1.40
J9700E 12100N	201 202	< 5	< 0.2	8.76	1070	1.0	4	1.31	< 0.5	42	11	347	8.49	2.62	1.17
J9700E 12150N	201 202	< 5	< 0.2	8.91	1720	2.0	< 2	0.57	0.5	20	114	58	4.34	2.73	0.89
J9700E 12200N	201 202	< 5	< 0.2	8.09	1860	2.0	< 2	0.74	0.5	21	136	82	5.19	2.35	1.24
J9700E 12250N	201 202	< 5	< 0.2	6.70	1270	1.5	< 2	1.75	< 0.5	16	93	49	3.59	1.97	0.89
J9700E 12300N	201 202	< 5	< 0.2	8.84	1650	2.0	< 2	1.00	< 0.5	26	121	81	5.16	2.64	0.90
J9900E 11050N	201 202	< 5	< 0.2	7.15	2150	2.5	< 2	1.38	0.5	11	74	56	3.04	2.16	0.93
J9900E 11100N	201 202	< 5	< 0.2	10.20	5380	3.0	< 2	0.58	1.5	18	127	66	3.86	3.88	0.83
J9900E 11150N	201 202	< 5	< 0.2	6.39	850	1.0	< 2	2.52	0.5	6	22	33	1.64	1.78	0.66
J9900E 11200N	201 202	< 5	< 0.2	6.24	1380	1.5	< 2	1.38	0.5	18	137	55	3.43	1.62	1.48
J9900E 11250N	201 202	< 5	< 0.2	4.88	1070	1.5	< 2	1.64	0.5	13	79	39	2.91	1.40	0.94
J9900E 11300N	201 202	< 5	< 0.2	6.04	1110	2.0	< 2	1.74	< 0.5	12	84	32	2.90	1.69	1.31
J9900E 11350N	201 202	< 5	< 0.2	6.38	1260	2.0	< 2	1.31	0.5	17	119	37	3.34	1.76	1.51
J9900E 11400N	201 202	< 5	< 0.2	6.61	1380	2.0	< 2	1.08	0.5	17	115	50	3.56	1.96	1.43

CERTIFICATION: Hart Buchler



Chemex Labs Ltd.

Analytical Chemists * Geochemists * Registered Assayers

212 Brooksbank Ave., North Vancouver
 British Columbia, Canada V7J 2C1
 PHONE: 604-984-0221 FAX: 604-984-0218

WESTMIN RESOURCES LTD.
 PROJECT: WOLVERINE
 P.O. BOX 49066, THE BENTALL CENTRE
 VANCOUVER, BC
 V7X 1C4

Page 1 of 3-B
 Total Pages: 4
 Certificate Date: 30-JUL-97
 Invoice No.: I9733708
 P.O. Number:
 Account: GP W

Project: 6410
 Comments: ATTN:DAVID TERRY-VANCOUVER OFFICE

CERTIFICATE OF ANALYSIS A9733708

SAMPLE	PREP CODE	Mn ppm (ICP)	Mo ppm (ICP)	Na % (ICP)	Ni ppm (ICP)	P ppm (ICP)	Pb ppm AAS	Sr ppm (ICP)	Ti % (ICP)	V ppm (ICP)	W ppm (ICP)	Zn ppm (ICP)			
J9500E 12200N	201 202	840	< 1	0.75	47	620	26	74	0.59	220	< 10	94			
J9500E 12250N	201 202	985	1	0.93	47	1330	12	123	0.44	225	10	156			
J9500E 12300N	201 202	655	< 1	0.76	33	920	8	197	0.18	93	< 10	136			
J9500E 12350N	201 202	525	< 1	0.99	69	1190	8	116	0.32	174	< 10	86			
J9500E 12400N	201 202	625	< 1	0.94	59	1120	8	134	0.30	158	< 10	80			
J9700E 11000N	201 202	470	< 1	1.47	46	840	14	150	0.31	122	< 10	70			
J9700E 11050N	201 202	840	< 1	1.14	50	710	28	162	0.36	190	< 10	104			
J9700E 11100N	201 202	385	1	0.66	70	1130	16	102	0.26	248	< 10	824			
J9700E 11150N	201 202	570	< 1	0.34	47	1070	8	137	0.24	178	< 10	158			
J9700E 11200N	201 202	590	< 1	1.31	52	920	12	175	0.26	109	< 10	64			
J9700E 11250N	201 202	305	4	0.63	61	1250	20	124	0.18	237	< 10	198			
J9700E 11300N	201 202	635	< 1	1.21	53	610	18	136	0.26	122	< 10	106			
J9700E 11350N	201 202	300	< 1	0.70	36	930	14	114	0.18	151	< 10	144			
J9700E 11400N	201 202	595	2	1.33	54	1060	12	298	0.21	119	< 10	68			
J9700E 11450N	201 202	620	4	0.91	94	1230	16	114	0.28	227	< 10	126			
J9700E 11500N	201 202	2520	3	2.04	102	2740	20	333	0.42	350	< 10	212			
J9700E 11550N	201 202	530	< 1	1.20	28	1200	14	274	0.15	74	< 10	254			
J9700E 11600N	201 202	875	1	1.07	111	940	6	119	0.47	190	< 10	132			
J9700E 11650N	201 202	1085	< 1	0.85	47	730	10	252	0.22	101	< 10	92			
J9700E 11700N	201 202	460	1	1.00	106	1500	16	150	0.32	209	< 10	118			
J9700E 11750N	201 202	300	1	1.03	74	1300	10	166	0.26	163	< 10	106			
J9700E 11800N	201 202	295	< 1	0.90	82	1140	10	209	0.27	156	< 10	98			
J9700E 11850N	201 202	3550	8	0.24	249	1240	30	214	0.10	97	< 10	68			
J9700E 11900N	201 202	625	< 1	0.97	76	590	14	106	0.36	214	< 10	88			
J9700E 11950N	201 202	565	< 1	0.95	36	660	16	120	0.38	145	< 10	78			
J9700E 12000N	201 202	605	< 1	0.89	22	800	4	266	0.13	63	< 10	40			
J9700E 12050N	201 202	860	< 1	1.10	59	800	30	130	0.41	340	< 10	92			
J9700E 12100N	201 202	965	< 1	0.63	80	1150	< 2	201	0.15	364	< 10	54			
J9700E 12150N	201 202	410	1	0.93	66	430	8	159	0.25	141	< 10	102			
J9700E 12200N	201 202	475	< 1	0.79	78	970	8	116	0.37	199	< 10	80			
J9700E 12250N	201 202	465	< 1	0.76	57	1020	8	164	0.19	120	< 10	82			
J9700E 12300N	201 202	570	< 1	0.80	84	990	10	158	0.23	152	< 10	92			
J9900E 11050N	201 202	390	< 1	1.11	49	540	22	139	0.27	129	< 10	74			
J9900E 11100N	201 202	555	2	0.52	69	790	10	78	0.28	180	10	116			
J9900E 11150N	201 202	415	< 1	1.95	22	880	6	475	0.17	47	< 10	66			
J9900E 11200N	201 202	535	< 1	1.09	93	920	14	152	0.36	141	< 10	84			
J9900E 11250N	201 202	640	< 1	0.99	53	930	12	161	0.28	106	< 10	62			
J9900E 11300N	201 202	690	< 1	1.37	67	1190	10	187	0.31	108	< 10	90			
J9900E 11350N	201 202	675	< 1	1.24	94	1170	10	148	0.35	138	< 10	122			
J9900E 11400N	201 202	500	< 1	1.15	97	1210	12	132	0.35	161	< 10	116			

CERTIFICATION:

David Terry



Chemex Labs Ltd.

Analytical Chemists * Geochemists * Registered Assayers
 212 Brooksbank Ave., North Vancouver
 British Columbia, Canada V7J 2C1
 PHONE: 604-984-0221 FAX: 604-984-0218

o: WESTMIN RESOURCES LTD.
 PROJECT: WOLVERINE
 P.O. BOX 49066, THE BENTALL CENTRE
 VANCOUVER, BC
 V7X 1C4

Page 1 of 4-A
 Total Pages : 4
 Certificate Date: 30-JUL-97
 Invoice No. : I9733708
 P.O. Number :
 Account : GP W

Project: 6410
 Comments: ATTN:DAVID TERRY-VANCOUVER OFFICE

CERTIFICATE OF ANALYSIS A9733708

SAMPLE	PREP CODE	Au ppb FA+AA	Ag ppm AAS	Al % (ICP)	Ba ppm (ICP)	Be ppm (ICP)	Bi ppm (ICP)	Ca % (ICP)	Cd ppm (ICP)	Co ppm (ICP)	Cr ppm (ICP)	Cu ppm (ICP)	Fe % (ICP)	K % (ICP)	Mg % (ICP)
J9900E 11450N	201 202	< 5	< 0.2	6.78	1500	2.0	< 2	1.35	1.5	18	94	44	3.89	1.95	1.26
J9900E 11500N	201 202	< 5	< 0.2	5.98	1380	1.5	< 2	1.86	1.5	14	78	53	4.03	1.67	1.23
J9900E 11550N	201 202	< 5	< 0.2	5.77	1190	1.5	< 2	1.94	0.5	15	86	58	3.03	1.71	1.18
J9900E 11600N	201 202	< 5	< 0.2	6.24	1510	1.5	< 2	1.67	1.5	11	97	130	2.48	1.56	1.23
J9900E 11700N	201 202	< 5	< 0.2	6.99	1620	2.0	< 2	1.15	0.5	20	117	48	3.98	1.89	1.38
J9900E 11750N	201 202	< 5	< 0.2	7.09	1650	1.5	< 2	1.73	1.5	22	128	69	4.03	2.17	1.34
J9900E 11800N	201 202	< 5	< 0.2	6.69	1610	2.0	< 2	0.77	0.5	19	124	54	4.46	2.03	1.51
J9900E 11850N	201 202	< 5	< 0.2	6.80	1560	2.0	< 2	0.88	0.5	22	112	67	4.29	1.98	1.44
J9900E 11900N	201 202	< 5	< 0.2	5.66	1090	1.5	< 2	2.25	0.5	10	70	45	2.41	1.52	1.03
J9900E 11950N	201 202	< 5	< 0.2	6.31	1490	2.0	< 2	1.56	< 0.5	22	94	79	4.00	1.85	1.17
J9900E 12000N	201 202	< 5	< 0.2	6.20	1150	1.5	< 2	1.25	< 0.5	38	154	79	7.56	2.26	0.68
J9900E 12050N	201 202	< 5	< 0.2	4.53	820	1.5	< 2	2.61	0.5	15	55	71	2.58	1.05	0.61
J9900E 12100N	201 202	< 5	< 0.2	8.66	1700	2.0	< 2	6.11	0.5	18	97	35	3.32	2.86	0.89

CERTIFICATION: _____

David Terry



Chemex Labs Ltd.

Analytical Chemists * Geochemists * Registered Assayers

212 Brooksbank Ave., North Vancouver
British Columbia, Canada V7J 2C1
PHONE: 604-984-0221 FAX: 604-984-0218

WESTMIN RESOURCES LTD.
PROJECT: WOLVERINE
P.O. BOX 49066, THE BENTALL CENTRE
VANCOUVER, BC
V7X 1C4

Page Number : 4-B
Total Pages : 4
Certificate Date: 30-JUL-97
Invoice No. : I9733708
P.O. Number :
Account : GP W

Project : 6410
Comments: ATTN:DAVID TERRY-VANCOUVER OFFICE

CERTIFICATE OF ANALYSIS A9733708

SAMPLE	PREP CODE	Mn ppm (ICP)	Mo ppm (ICP)	Na % (ICP)	Ni ppm (ICP)	P ppm (ICP)	Pb ppm AAS	Sr ppm (ICP)	Ti % (ICP)	V ppm (ICP)	W ppm (ICP)	Zn ppm (ICP)			
J9900E 11450N	201 202	680	< 1	1.11	62	1190	12	153	0.35	146	< 10	90			
J9900E 11500N	201 202	520	< 1	0.81	62	1180	8	214	0.22	157	< 10	124			
J9900E 11550N	201 202	705	< 1	0.86	60	1310	10	184	0.28	155	< 10	124			
J9900E 11600N	201 202	675	< 1	0.71	61	1230	12	192	0.27	179	< 10	108			
J9900E 11700N	201 202	720	1	1.01	66	1230	14	134	0.37	173	< 10	108			
J9900E 11750N	201 202	660	4	0.79	88	1260	8	143	0.29	185	< 10	122			
J9900E 11800N	201 202	490	< 1	1.10	69	1330	8	99	0.35	202	< 10	112			
J9900E 11850N	201 202	580	< 1	0.97	78	1310	10	105	0.30	194	10	110			
J9900E 11900N	201 202	290	< 1	1.01	36	1280	10	218	0.21	129	< 10	96			
J9900E 11950N	201 202	675	< 1	0.97	58	770	10	181	0.24	142	< 10	82			
J9900E 12000N	201 202	1235	4	0.55	123	880	8	111	0.18	272	< 10	56			
J9900E 12050N	201 202	760	< 1	0.77	40	1160	8	162	0.21	84	< 10	46			
J9900E 12100N	201 202	605	1	0.81	46	610	6	221	0.28	97	< 10	78			

CERTIFICATION: Hart Bickler



Chemex Labs Ltd.

Analytical Chemists * Geochemists * Registered Assayers
212 Brooksbank Ave., North Vancouver
British Columbia, Canada V7J 2C1
PHONE: 604-984-0221

Client: WESTMIN RESOURCES LTD.

P.O. BOX 49066, THE BENTALL CENTRE
VANCOUVER, BC
V7X 1C4

INVOICE NUMBER **I 9 7 4 0 0 3 6**

BILLING INFORMATION

Date: 12-SEP-97
Project: 6410
P.O. No.:
Account: GP W

Comments: ATTN:DAVID TERRY-VANCOUVER
OFFICE

Billing: For analysis performed on
Certificate A9740036

Terms: Payment due on receipt of invoice
1.25% per month (15% per annum)
charged on overdue accounts

Please Remit Payments to:

CHEMEX LABS LTD.
212 Brooksbank Ave.,
North Vancouver, B.C.
Canada V7J 2C1

# OF SAMPLES	ANALYSED FOR CODE - DESCRIPTION	UNIT PRICE	SAMPLE PRICE	AMOUNT	
47	201 - Dry, sieve to -80 mesh	1.25			
	202 - save reject	0.85			
	ICP-24	10.50			
	983 - Au ppb FA+AA	9.75	22.35	1050.45	
				Total Cost \$	1050.45
				Client Discount (25%) \$	<u>-262.61</u>
				Net Cost \$	787.84
				(Reg# R100938885) GST \$	<u>55.15</u>
				TOTAL PAYABLE (CDN) \$	842.99

COPY



Chemex Labs Ltd.

Analytical Chemists * Geochemists * Registered Assayers

212 Brooksbank Ave., North Vancouver
 British Columbia, Canada V7J 2C1
 PHONE: 604-984-0221 FAX: 604-984-0218

to: WESTMIN RESOURCES LTD.
 PROJECT: WOLVERINE
 P.O. BOX 49066, THE BENTALL CENTRE
 VANCOUVER, BC
 V7X 1C4

QC Pa. 1-A
 Tot QC Pg: 1
 Date: 05-SEP-97
 Invoice #: 19740036
 P.O. #: GP W

Project: 6410
 Comments: ATTN:DAVID TERRY-VANCOUVER OFFICE

QC DATA OF CERTIFICATE A9740036

STD/DUP/BLANK DESCRIPTION	QC TYPE	PAGE NO.	Au ppb FA+AA	Ag ppm AAS	Al % (ICP)	Ba ppm (ICP)	Be ppm (ICP)	Bi ppm (ICP)	Ca % (ICP)	Cd ppm (ICP)	Co ppm (ICP)	Cr ppm (ICP)	Cu ppm (ICP)	Fe % (ICP)	K % (ICP)	Mg % (ICP)
ADS-1 CHEMEX MEAN	Std2	1	475 470	----	----	----	----	----	----	----	----	----	----	----	----	----
BL-C CHEMEX MEAN	Blnk	1	< 5 < 5	----	----	----	----	----	----	----	----	----	----	----	----	----
CR-1 CHEMEX MEAN	Std1	1	950	----	----	----	----	----	----	----	----	----	----	----	----	----
CR-1 CHEMEX MEAN	Std1	2	940 923	----	----	----	----	----	----	----	----	----	----	----	----	----
G96-TOT CHEMEX MEAN	Std2	1	----	----	7.76	1120	1.5	2	2.12	1.5	17	97	183	4.83	1.87	1.02
G96-TOT CHEMEX MEAN	Std1	2	----	----	7.92 7.60	1130 1135	1.5 1.1	< 2 8	2.14 2.13	1.5 0.9	18 17	95 98	190 177	4.86 4.60	1.91 1.82	1.00 1.00
GEO-96 CHEMEX MEAN	Std1	1	----	5.0	7.20	1040	1.0	2	2.00	1.5	18	90	180	4.90	1.80	0.96
GEO-96 CHEMEX MEAN	Std2	1	----	5.2	----	----	----	----	----	----	----	----	----	----	----	----
GEO-96 CHEMEX MEAN	Std1	2	----	5.0 5.6	----	----	----	< 2	----	----	----	----	----	----	----	----
SIO2-G2 CHEMEX MEAN	Blnk	1	----	< 0.2 < 0.2	----	----	----	----	----	----	----	----	----	----	----	----
SIO2-T4 CHEMEX MEAN	Blnk	1	----	----	0.25 0.26	30 30	< 0.5 0.5	< 2 2	0.02 0.03	< 0.5 1.0	< 1 1	5 1	3 3	0.07 0.07	0.05 0.05	0.01 0.01
J10100E 11050N	Dupl-01		< 5	< 0.2	5.32	1860	1.5	< 2	1.62	1.0	15	92	43	3.35	1.65	1.17
J10100E 11050N	Origl-01		< 5	< 0.2	5.36	1840	1.5	< 2	1.62	1.0	15	88	44	3.39	1.68	1.14

CERTIFICATION: Hartl Buchler



Chemex Labs Ltd.

Analytical Chemists * Geochemists * Registered Assayers

212 Brooksbank Ave., North Vancouver
 British Columbia, Canada V7J 2C1
 PHONE: 604-984-0221 FAX: 604-984-0218

o: WESTMIN RESOURCES LTD.
 PROJECT: WOLVERINE
 P.O. BOX 49066, THE BENTALL CENTRE
 VANCOUVER, BC
 V7X 1C4

QC Pa. 1-B
 Tot QC Pg: 1
 Date: 05-SEP-97
 Invoice #: 19740036
 P.O. #: GPW

Project: 6410
 Comments: ATTN:DAVID TERRY-VANCOUVER OFFICE

QC DATA OF CERTIFICATE A9740036

STD/DUP/BLANK DESCRIPTION	QC TYPE	PAGE NO.	Mn ppm (ICP)	Mo ppm (ICP)	Na % (ICP)	Ni ppm (ICP)	P ppm (ICP)	Pb ppm AAS	Sr ppm (ICP)	Ti % (ICP)	V ppm (ICP)	W ppm (ICP)	Zn ppm (ICP)			
ADS-1 CHEMEX MEAN	Std2	1	----	----	----	----	----	----	----	----	----	----	----			
BL-C CHEMEX MEAN	Blnk	1	----	----	----	----	----	----	----	----	----	----	----			
CR-1 CR-1 CHEMEX MEAN	Std1	1	----	----	----	----	----	----	----	----	----	----	----			
	Std1	2	----	----	----	----	----	----	----	----	----	----	----			
G96-TOT G96-TOT CHEMEX MEAN	Std2	1	1060	7	1.00	25	610	----	254	0.35	167	10	184			
	Std1	2	1080	9	0.97	25	610	----	262	0.35	170	10	192			
	---	---	1025	8	1.00	24	624	----	236	0.34	160	< 10	185			
GEO-96 GEO-96 GEO-96 CHEMEX MEAN	Std1	1	1000	8	1.00	23	610	116	245	0.32	157	10	180			
	Std2	1	----	----	----	----	----	124	----	----	----	----	----			
	Std1	2	----	----	----	----	----	130	----	----	----	----	----			
	---	---	----	----	----	----	----	125	----	----	----	----	----			
SIO2-G2 CHEMEX MEAN	Blnk	1	----	----	----	----	----	< 2	----	----	----	----	----			
	---	---	----	----	----	----	----	< 2	----	----	----	----	----			
SIO2-T4 CHEMEX MEAN	Blnk	1	< 5	< 1	0.03	< 1	250	----	297	0.01	4	< 10	< 2			
	---	---	5	1	0.01	1	248	----	269	0.01	4	10	2			
J10100E 11050N	Dupl	01	780	1	0.92	56	1250	4	153	0.29	173	< 10	124			
	Origl	01	785	2	0.90	57	1200	4	153	0.29	170	< 10	126			

CERTIFICATION: David Terry



Chemex Labs Ltd.

Analytical Chemists * Geochemists * Registered Assayers

212 Brooksbank Ave., North Vancouver
British Columbia, Canada V7J 2C1
PHONE: 604-984-0221 FAX: 604-984-0218

J: WESTMIN RESOURCES LTD.
PROJECT: WOLVERINE
P.O. BOX 49066, THE BENTALL CENTRE
VANCOUVER, BC
V7X 1C4

A9740036

Comments: ATTN:DAVID TERRY-VANCOUVER OFFICE

CERTIFICATE

A9740036

(GP W) - WESTMIN RESOURCES LTD.

Project: 6410
P.O. #:

Samples submitted to our lab in Vancouver, BC.
This report was printed on 5-SEP-97.

SAMPLE PREPARATION

CHEMEX CODE	NUMBER SAMPLES	DESCRIPTION
201	47	Dry, sieve to -80 mesh
202	47	save reject
285	47	ICP - HF digestion charge

ANALYTICAL PROCEDURES

CHEMEX CODE	NUMBER SAMPLES	DESCRIPTION	METHOD	DETECTION LIMIT	UPPER LIMIT
983	47	Au ppb: Fuse 30 g sample	FA-AAS	5	10000
578	47	Ag ppm: 24 element, rock & core	AAS	0.2	100.0
573	47	Al %: 24 element, rock & core	ICP-AES	0.01	25.0
565	47	Ba ppm: 24 element, rock & core	ICP-AES	10	10000
575	47	Be ppm: 24 element, rock & core	ICP-AES	0.5	1000
561	47	Bi ppm: 24 element, rock & core	ICP-AES	2	10000
576	47	Ca %: 24 element, rock & core	ICP-AES	0.01	25.0
562	47	Cd ppm: 24 element, rock & core	ICP-AES	0.5	500
563	47	Co ppm: 24 element, rock & core	ICP-AES	1	10000
569	47	Cr ppm: 24 element, rock & core	ICP-AES	1	10000
577	47	Cu ppm: 24 element, rock & core	ICP-AES	1	10000
566	47	Fe %: 24 element, rock & core	ICP-AES	0.01	25.0
584	47	K %: 24 element, rock & core	ICP-AES	0.01	10.00
570	47	Mg %: 24 element, rock & core	ICP-AES	0.01	15.00
568	47	Mn ppm: 24 element, rock & core	ICP-AES	5	10000
554	47	Mo ppm: 24 element, rock & core	ICP-AES	1	10000
583	47	Na %: 24 element, rock & core	ICP-AES	0.01	10.00
564	47	Ni ppm: 24 element, rock & core	ICP-AES	1	10000
559	47	P ppm: 24 element, rock & core	ICP-AES	10	10000
560	47	Pb ppm: 24 element, rock & core	AAS	2	10000
582	47	Sr ppm: 24 element, rock & core	ICP-AES	1	10000
579	47	Ti %: 24 element, rock & core	ICP-AES	0.01	10.00
572	47	V ppm: 24 element, rock & core	ICP-AES	1	10000
556	47	W ppm: 24 element, rock & core	ICP-AES	10	10000
558	47	Zn ppm: 24 element, rock & core	ICP-AES	2	10000



Chemex Labs Ltd.

Analytical Chemists * Geochemists * Registered Assayers

212 Brooksbank Ave., North Vancouver
British Columbia, Canada V7J 2C1
PHONE: 604-984-0221 FAX: 604-984-0218

Client: WESTMIN RESOURCES LTD.
PROJECT: WOLVERINE
P.O. BOX 49066, THE BENTALL CENTRE
VANCOUVER, BC
V7X 1C4

Project: 6410
Comments: ATTN:DAVID TERRY-VANCOUVER OFFICE

Page 1 of 2
Total Pages: 2
Certificate Date: 05-SEP-97
Invoice No.: I9740036
P.O. Number:
Account: GP W

CERTIFICATE OF ANALYSIS A9740036

SAMPLE	PREP CODE	Au ppb FA+AA	Ag ppm AAS	Al % (ICP)	Ba ppm (ICP)	Be ppm (ICP)	Bi ppm (ICP)	Ca % (ICP)	Cd ppm (ICP)	Co ppm (ICP)	Cr ppm (ICP)	Cu ppm (ICP)	Fe % (ICP)	K % (ICP)	Mg % (ICP)
J10100E 11050N	201 202	< 5	< 0.2	5.36	1840	1.5	< 2	1.62	1.0	15	88	44	3.39	1.68	1.14
J10100E 11100N	201 202	< 5	< 0.2	4.63	990	1.0	< 2	1.66	1.5	14	102	28	3.09	1.30	1.26
J10100E 11150N	201 202	< 5	< 0.2	5.07	1150	1.5	< 2	1.95	0.5	10	83	36	2.66	1.50	1.19
J10100E 11200N	201 202	< 5	< 0.2	5.30	1150	1.5	2	1.82	1.0	11	78	36	2.68	1.59	1.13
J10100E 11250N	-- --	NotRed	NotRed	NotRed	NotRed	NotRed	NotRed	NotRed	NotRed	NotRed	NotRed	NotRed	NotRed	NotRed	NotRed
J10100E 11300N	201 202	< 5	0.6	5.92	1610	2.0	< 2	1.53	1.5	17	84	93	4.51	1.59	1.13
J10100E 11350N	201 202	< 5	0.2	6.45	1110	1.5	< 2	1.94	0.5	7	42	33	2.38	1.86	0.80
J10100E 11400N	201 202	< 5	< 0.2	5.87	1400	1.5	< 2	1.19	0.5	16	100	50	3.44	1.80	1.07
J10100E 11450N	201 202	< 5	0.2	5.23	1330	1.5	< 2	1.16	0.5	11	98	34	3.13	1.57	1.04
J10100E 11500N	201 202	< 5	< 0.2	5.99	1550	1.5	< 2	1.04	0.5	14	97	42	3.45	1.96	1.01
J10100E 11550N	201 202	< 5	0.6	5.72	1140	1.5	< 2	1.96	< 0.5	16	52	53	3.34	1.58	0.90
J10100E 11600N	-- --	NotRed	NotRed	NotRed	NotRed	NotRed	NotRed	NotRed	NotRed	NotRed	NotRed	NotRed	NotRed	NotRed	NotRed
J10100E 11650N	201 202	< 5	< 0.2	6.52	1260	1.5	< 2	0.39	< 0.5	10	101	27	3.83	1.88	0.91
J10100E 11700N	201 202	< 5	< 0.2	6.60	1280	2.0	< 2	0.43	0.5	17	93	69	5.33	1.94	1.12
J10100E 11750N	201 202	< 5	< 0.2	6.94	1490	1.5	< 2	0.37	< 0.5	12	97	28	5.53	1.96	1.23
J10100E 11800N	201 202	< 5	< 0.2	8.78	1850	2.5	< 2	7.01	0.5	12	94	39	3.13	3.66	0.72
J10100E 11850N	201 202	< 5	< 0.2	6.94	1650	2.0	< 2	0.66	< 0.5	20	110	63	4.88	2.03	1.22
J10100E 11900N	201 202	< 5	< 0.2	5.00	1480	1.5	< 2	1.53	2.5	23	73	49	4.92	1.53	0.79
J10100E 11950N	201 202	< 5	0.6	5.33	1060	1.5	2	1.61	1.5	18	76	44	3.66	1.39	0.69
J10300E 11050N	201 202	< 5	< 0.2	6.02	1580	1.5	< 2	1.25	0.5	15	108	51	3.65	1.82	1.18
J10300E 11100N	201 202	< 5	0.2	5.57	1540	1.5	2	1.08	0.5	15	81	36	3.31	1.70	1.07
J10300E 11150N	201 202	< 5	< 0.2	5.87	1470	1.5	8	1.71	0.5	12	89	29	3.26	1.61	1.48
J10300E 11200N	201 202	< 5	< 0.2	4.21	870	1.0	2	2.94	0.5	11	45	232	2.18	1.21	0.72
J10300E 11250N	201 202	< 5	0.6	4.79	710	0.5	< 2	2.66	0.5	4	12	24	1.29	1.30	0.49
J10300E 11300N	201 202	< 5	0.4	4.14	950	1.0	< 2	2.54	2.0	13	49	73	2.36	1.10	0.68
J10300E 11350N	201 202	< 5	0.4	5.68	1430	2.0	2	1.09	0.5	12	105	37	3.05	1.90	0.99
J10300E 11400N	201 202	< 5	< 0.2	4.78	1070	1.5	< 2	2.21	1.0	15	78	157	3.66	1.25	0.98
J10300E 11450N	201 202	< 5	< 0.2	4.50	730	0.5	< 2	3.14	1.0	4	31	40	1.46	1.30	0.74
J10300E 11500N	201 202	< 5	< 0.2	4.96	1030	1.5	< 2	2.00	< 0.5	11	73	40	2.56	1.56	1.00
J10300E 11550N	201 202	< 5	0.4	6.48	1040	1.5	< 2	1.79	0.5	12	40	48	2.74	1.74	0.63
J10300E 11600N	201 202	< 5	< 0.2	4.31	1160	1.0	< 2	0.80	0.5	11	61	27	2.54	1.29	0.81
J10300E 11650N	201 202	< 5	< 0.2	6.62	1550	1.5	6	0.45	0.5	19	107	23	4.69	1.82	1.26
J10300E 11700N	201 202	< 5	< 0.2	6.69	1450	2.0	< 2	0.85	< 0.5	7	93	18	3.22	2.02	0.82
J10300E 11750N	201 202	< 5	< 0.2	6.94	1580	2.0	< 2	0.97	0.5	21	122	55	3.62	2.24	1.24
J10300E 11800N	201 202	< 5	0.4	4.86	1040	1.5	< 2	1.50	0.5	19	77	45	3.63	1.17	0.73
J10300E 11850N	201 202	< 5	0.2	6.45	1240	1.5	< 2	0.52	0.5	13	109	29	4.49	1.74	0.75
J10500E 11050N	201 202	< 5	< 0.2	4.62	1020	1.5	< 2	2.30	1.5	10	70	31	2.41	1.35	0.90
J10500E 11100N	201 202	< 5	< 0.2	5.53	1260	2.0	< 2	1.22	0.5	17	115	39	3.44	1.80	1.02
J10500E 11150N	201 202	< 5	< 0.2	5.11	980	1.5	< 2	1.93	0.5	8	68	27	2.09	1.37	0.87
J10500E 11200N	201 202	< 5	1.0	5.25	1010	1.5	2	1.94	0.5	14	101	39	3.08	1.50	1.00

CERTIFICATION:

David Buchler



Chemex Labs Ltd.

Analytical Chemists * Geochemists * Registered Assayers

212 Brooksbank Ave., North Vancouver
British Columbia, Canada V7J 2C1
PHONE: 604-984-0221 FAX: 604-984-0218

To: WESTMIN RESOURCES LTD.
PROJECT: WOLVERINE
P.O. BOX 49066, THE BENTALL CENTRE
VANCOUVER, BC
V7X 1C4

Page: 1-B
Total Pages: 2
Certificate Date: 05-SEP-97
Invoice No.: I9740036
P.O. Number:
Account: GP W

Project: 6410
Comments: ATTN:DAVID TERRY-VANCOUVER OFFICE

CERTIFICATE OF ANALYSIS A9740036

SAMPLE	PREP CODE	Mn ppm (ICP)	Mo ppm (ICP)	Na % (ICP)	Ni ppm (ICP)	P ppm (ICP)	Pb ppm AAS	Sr ppm (ICP)	Ti % (ICP)	V ppm (ICP)	W ppm (ICP)	Zn ppm (ICP)			
J10100E 11050N	201 202	785	2	0.90	57	1200	4	153	0.29	170	< 10	126			
J10100E 11100N	201 202	580	1	0.86	58	1190	4	146	0.33	136	< 10	138			
J10100E 11150N	201 202	490	< 1	0.85	47	1300	< 2	195	0.24	141	< 10	146			
J10100E 11200N	201 202	575	< 1	0.98	46	1450	4	205	0.25	142	< 10	134			
J10100E 11250N	-- --	NotRed	NotRed	NotRed	NotRed	NotRed	NotRed	NotRed	NotRed	NotRed	NotRed	NotRed			
J10100E 11300N	201 202	730	1	1.14	72	1410	10	161	0.28	178	< 10	94			
J10100E 11350N	201 202	650	1	1.85	27	770	2	418	0.21	95	< 10	86			
J10100E 11400N	201 202	805	1	1.07	66	1210	4	166	0.29	174	< 10	94			
J10100E 11450N	201 202	405	1	0.85	46	1120	4	130	0.29	171	< 10	76			
J10100E 11500N	201 202	430	1	0.81	51	1470	4	135	0.28	186	< 10	72			
J10100E 11550N	201 202	680	1	1.37	34	1310	< 2	305	0.32	134	< 10	54			
J10100E 11600N	-- --	NotRed	NotRed	NotRed	NotRed	NotRed	NotRed	NotRed	NotRed	NotRed	NotRed	NotRed			
J10100E 11650N	201 202	315	3	0.84	31	470	< 2	84	0.32	231	< 10	58			
J10100E 11700N	201 202	425	4	0.84	50	850	10	118	0.40	225	< 10	98			
J10100E 11750N	201 202	515	2	0.86	32	560	12	105	0.51	226	< 10	98			
J10100E 11800N	201 202	590	1	0.52	48	600	4	231	0.22	108	< 10	46			
J10100E 11850N	201 202	620	2	0.91	84	1150	4	119	0.31	171	< 10	82			
J10100E 11900N	201 202	5200	5	0.57	108	1950	< 2	175	0.12	117	< 10	550			
J10100E 11950N	201 202	2190	1	1.09	46	1710	4	215	0.22	90	< 10	82			
J10300E 11050N	201 202	605	2	0.97	57	990	8	135	0.27	168	< 10	92			
J10300E 11100N	201 202	800	1	1.04	46	870	14	162	0.30	144	< 10	110			
J10300E 11150N	201 202	470	< 1	1.22	41	670	4	162	0.35	142	< 10	74			
J10300E 11200N	201 202	610	1	0.98	31	1000	< 2	336	0.18	100	< 10	42			
J10300E 11250N	201 202	405	1	1.75	17	610	< 2	459	0.15	32	< 10	34			
J10300E 11300N	201 202	1250	< 1	1.05	74	1020	6	300	0.16	71	< 10	64			
J10300E 11350N	201 202	420	< 1	0.87	51	1260	6	131	0.26	184	< 10	82			
J10300E 11400N	201 202	690	< 1	0.99	73	1080	6	202	0.24	115	< 10	68			
J10300E 11450N	201 202	405	2	1.39	16	1120	< 2	438	0.15	63	< 10	64			
J10300E 11500N	201 202	470	1	0.98	39	1020	2	210	0.22	119	< 10	56			
J10300E 11550N	201 202	1170	1	1.67	27	880	10	344	0.21	71	< 10	62			
J10300E 11600N	201 202	595	< 1	0.81	32	660	14	129	0.23	113	< 10	80			
J10300E 11650N	201 202	885	1	0.96	31	640	12	110	0.54	221	< 10	90			
J10300E 11700N	201 202	285	< 1	1.02	26	700	6	133	0.38	162	< 10	62			
J10300E 11750N	201 202	350	1	0.95	79	1160	8	133	0.26	163	< 10	108			
J10300E 11800N	201 202	1020	2	0.86	39	2280	6	177	0.26	108	< 10	42			
J10300E 11850N	201 202	345	3	0.95	36	580	4	136	0.29	173	< 10	42			
J10500E 11050N	201 202	1180	1	0.92	46	960	4	233	0.21	114	< 10	72			
J10500E 11100N	201 202	420	1	0.97	67	1250	8	145	0.30	167	< 10	104			
J10500E 11150N	201 202	270	< 1	1.15	38	870	4	252	0.23	111	< 10	96			
J10500E 11200N	201 202	835	1	1.06	56	1040	4	185	0.21	134	< 10	94			

CERTIFICATION:

David Bickler



Chemex Labs Ltd.

Analytical Chemists * Geochemists * Registered Assayers

212 Brooksbank Ave., North Vancouver
British Columbia, Canada V7J 2C1
PHONE: 604-984-0221 FAX: 604-984-0218

o: WESTMIN RESOURCES LTD.
PROJECT: WOLVERINE
P.O. BOX 49066, THE BENTALL CENTRE
VANCOUVER, BC
V7X 1C4

Project: 6410
Comments: ATTN:DAVID TERRY-VANCOUVER OFFICE

Page 1 of 2-A
Total Pages :2
Certificate Date: 05-SEP-97
Invoice No. : I9740036
P.O. Number :
Account : GPW

CERTIFICATE OF ANALYSIS A9740036

SAMPLE	PREP CODE		Au ppb FA+AA	Ag ppm AAS	Al % (ICP)	Ba ppm (ICP)	Be ppm (ICP)	Bi ppm (ICP)	Ca % (ICP)	Cd ppm (ICP)	Co ppm (ICP)	Cr ppm (ICP)	Cu ppm (ICP)	Fe % (ICP)	K % (ICP)	Mg % (ICP)
J10500E 11250N	201	202	< 5	< 0.2	5.13	1250	1.5	< 2	1.94	0.5	14	88	47	2.96	1.60	0.91
J10500E 11300N	201	202	< 5	< 0.2	6.31	1280	2.0	< 2	1.25	0.5	14	101	51	3.06	1.93	1.12
J10500E 11350N	201	202	< 5	< 0.2	9.08	2730	2.5	< 2	0.96	1.0	18	102	54	4.64	3.17	1.66
J10500E 11400N	201	202	< 5	< 0.2	7.13	1470	2.0	< 2	0.76	0.5	22	126	58	4.43	2.08	1.42
J10500E 11450N	201	202	< 5	< 0.2	6.41	1380	2.0	2	0.95	< 0.5	13	102	38	3.46	1.92	1.17
J10500E 11500N	201	202	< 5	< 0.2	6.72	1590	2.0	< 2	0.91	0.5	16	111	37	3.75	2.04	1.23
J10500E 11550N	201	202	< 5	< 0.2	8.36	1340	2.0	< 2	0.55	< 0.5	1	74	9	1.38	2.52	0.65
J10500E 11600N	201	202	< 5	< 0.2	5.90	1120	2.0	< 2	1.44	< 0.5	13	71	58	3.34	1.52	0.99
J10500E 11650N	201	202	< 5	< 0.2	4.34	1670	1.0	< 2	1.77	2.0	24	65	32	7.44	1.30	0.77

CERTIFICATION: Hartl Buchler



Chemex Labs Ltd.

Analytical Chemists * Geochemists * Registered Assayers

212 Brooksbank Ave., North Vancouver
British Columbia, Canada V7J 2C1
PHONE: 604-984-0221 FAX: 604-984-0218

WESTMIN RESOURCES LTD.
PROJECT: WOLVERINE
P.O. BOX 49066, THE BENTALL CENTRE
VANCOUVER, BC
V7X 1C4

Project : 6410
Comments: ATTN:DAVID TERRY-VANCOUVER OFFICE

Page 1 of 2-B
Total Pages : 2
Certificate Date: 05-SEP-97
Invoice No. : I9740036
P.O. Number :
Account : GP W

CERTIFICATE OF ANALYSIS A9740036

SAMPLE	PREP CODE	Mn ppm (ICP)	Mo ppm (ICP)	Na % (ICP)	Ni ppm (ICP)	P ppm (ICP)	Pb ppm AAS	Sr ppm (ICP)	Ti % (ICP)	V ppm (ICP)	W ppm (ICP)	Zn ppm (ICP)			
J10500E 11250N	201 202	725	1	0.79	51	1290	6	172	0.25	144	< 10	86			
J10500E 11300N	201 202	305	3	1.08	49	1210	14	161	0.30	164	< 10	98			
J10500E 11350N	201 202	590	4	0.75	55	910	4	100	0.27	152	< 10	138			
J10500E 11400N	201 202	510	1	0.84	62	1380	4	107	0.31	213	< 10	92			
J10500E 11450N	201 202	425	< 1	0.90	48	980	6	117	0.31	171	< 10	82			
J10500E 11500N	201 202	460	1	0.89	51	1020	8	110	0.33	171	< 10	92			
J10500E 11550N	201 202	140	1	0.94	8	160	< 2	150	0.26	97	< 10	56			
J10500E 11600N	201 202	505	< 1	1.29	42	1130	8	203	0.32	113	< 10	50			
J10500E 11650N	201 202	>10000	3	0.62	112	2520	< 2	203	0.20	96	< 10	420			

CERTIFICATION: Hart Buchler

APPENDIX F
GROUND GEOPHYSICS REPORT

WESTMIN RESOURCES LIMITED
GROUND TOTAL MAGNETIC FIELD
AND HLEM SURVEYS OF THE TOE PROPERTY,
FINLAYSON AREA,
SOUTHERN YUKON TERRITORY

M.A. Power M.Sc. P. Geo.

PROPERTIES

TOE

Centred at: 61° 29' N 130° 15' W
NTS: 105 G 8
Mining District: Watson Lake, YT
Date: August 7, 1997

SUMMARY

Ground total magnetic field and horizontal loop electromagnetic field (HLEM) surveys were conducted on the Toe Property near Wolverine Lake from June 21-28, 1997. The surveys were conducted to map stratigraphy favourable for the location of volcanogenic massive sulphide (VMS) deposits and, if possible, to directly locate VMS mineralization based on the geophysical responses. HLEM surveys were conducted using a coil spacing of 100 m, station spacing of 25 m and reading frequencies of 440, 880, 1760 and 3520 Hz. Total magnetic field surveys were conducted using a station spacing of 12.5 m. A total of 24.0 line-km was surveyed on the Toe grid.

Eleven HLEM conductors generally conformable with the mapped stratigraphy were identified. Several of these are probably graphitic argillite beds based on their low coincident magnetic field response, high conductance and wide response width. Conductors **TO-1, 5, 6** and **TO-11** are closely associated with a positive magnetic field anomaly, have high conductances and narrow target widths. These targets merit additional investigation.

TABLE OF CONTENTS

1.0	INTRODUCTION	1
2.0	SURVEY PROCEDURES	1
3.0	GEOLOGICAL SUMMARY AND TARGET CHARACTERISTICS	2
4.0	HLEM AND MAGNETIC FIELD INTERPRETATION PROCEDURES	5
5.0	DATA PRESENTATION AND FORMATS	8
6.0	RESULTS	9
7.0	CONCLUSIONS	11
8.0	RECOMMENDATIONS	11
	REFERENCES CITED	12
	APPENDIX A. CERTIFICATE	13
	APPENDIX B. ANOMALY LISTINGS	14
	APPENDIX C. IP/Q VERSUS RESPONSE PARAMETER PLOTS	20
	APPENDIX D. NOTES ON THE HLEM METHOD	21

1.0 INTRODUCTION

Amerok Geosciences Ltd. was retained by Westmin Resources Limited to conduct ground total magnetic field and horizontal loop electromagnetic field (HLEM) surveys on the Toe Property near Wolverine Lake in the south central Yukon Territory. The surveys were conducted from June 21 to June 28, 1997 in support of an exploration program for volcanogenic massive sulphide deposits. This report describes the surveys performed, the data, results and interpretation.

2.0 SURVEY PROCEDURES

A cut grid consisting of 24.0 line-km was centred over the inferred location of the Ore Sequence. The grid consisted of a cut, slope-corrected base line and cut, slope chained (not slope corrected) survey lines. Grids were picketed at a 25 m interval using tagged survey lathe.

Ground total magnetic field surveys and HLEM surveys were conducted on the Toe Property on June 21-25, and 27-28, 1997. The HLEM survey was conducted by M. Power and D. Hall while the magnetometer surveys were conducted by C. Lee and D. Smith. The geophysical surveys were performed with the following instruments:

HLEM Instruments

Apex Parametrics Maxmin I-9 with attached MMC (datalogger/computer). This instrument operates at 110, 220, 440, 880, 1760, 3520, 7040, 14,080 and 28,160 Hz.

Magnetic field Instruments

2 Omni Plus proton precession magnetometers, 1 Omni IV proton precession magnetometer.

Other

P-75 laptop computer, Fujitsu colour printer. All data was processed and plotted in GEOPAK.

The HLEM surveys were performed using the 100 m cable and frequencies of 440, 880, 1760 and 3520 Hz reading stations every 25 m. The HLEM method requires that the coils be held a constant distance apart and be coplanar. In steep irregular terrain, the coils will frequently be less than the nominal coil spacing (short coiling) and may

not be coplanar. These variations in coil geometry produce strong in-phase errors and these must be removed from the data before plotting and interpretation. The method used to mitigate these effects requires a slope-chained grid and requires the operator to measure the station-to-station terrain slope in percent with a clinometer. This is normally done by the receiver operator who was in the lead position on most surveys. The correct slope required to maintain the coils coplanar is the arithmetic average of the station to station slopes in the interval between the two coils. The operators hold the coils coplanar during the surveys by holding their coils at this orientation which is calculated and displayed for each reading station by the Maxmin MMC. The effect of short coiling created by irregular topography was removed with Apex Parametrics data processing software (MMCFIX1). The numerical method is described in Varre (1990)(pp AII-3-4).

The magnetic field surveys were conducted using a 12.5 m station spacing. The base station magnetometer was synchronized with the field units daily, prior to the surveys and cycled at 15 to 20 s during the surveys. Corrections to the field data for temporal geomagnetic variation during the surveys were performed either by on-board software or, after dumping, by computer software. The data was levelled between operators.

3.0 GEOLOGICAL SUMMARY AND TARGET CHARACTERISTICS

The following notes are drawn from discussions with A. Turner, P. Lhotka and D. Terry and form the framework within which the geophysical data was interpreted. The PUCK grid is underlain by the mid-Devonian Middle Unit of Mortensen and Jilsen (1985). From top to bottom the rock units encountered on the property include:

Unit	Thickness	Lithology
Mafic-intermediate volcanics	?	Predominantly andesites
Ore sequence	to 200 m	Aphyric rhyolite and lesser argillite, calcite-pyrite and barite exhalite, iron formation and massive sulphides
Footwall argillite	500 m or more	Siliceous to carbonaceous, locally graphitic black argillite
Porphyritic rhyolite unit	variable	Intrudes footwall argillite. Argillaceous quartz-eye feldspar crystal tuff; quartz feldspar intrusive flows; quartz-eye bearing crystal tuff.

The footwall argillite contains both conductive and non-conductive sections depending upon the graphite content. The argillite is weakly mineralized with disseminated pyrite and is strongly foliated subparallel to compositional layering. The porphyritic rhyolite occurs in domal complexes intruding the argillite. These appear to be the hypabyssal sources of the extrusive rocks and pyroclastics in the Ore Sequence. The complexes are composed of an intrusive core draped by a fragmental quartz-eye feldspar crystal tuff containing silica encapsulated clasts of footwall argillite. The Ore Sequence overlies both the footwall argillite and the porphyritic rhyolite and consists of rhyolite with interbedded graphitic argillite over the dome complexes grading laterally into tuffaceous mudstone. The massive sulphides are located on the flanks of the Wolverine intrusive complex at the base of the Ore Sequence. An extensive magnetite iron formation occurs from 30 to 80 m up-section of the massive sulphide horizon and extends laterally for up to 10 km. This horizon consists of one to two separate magnetite rich siliceous exhalite layers up to 5 m thick. Above the massive sulphides, a calcite-pyrite exhalative unit is also encountered but this is not laterally extensive. The Ore Sequence varies in thickness along strike with pinching occurring over the intrusive complexes; this probably reflects the influence of paleotopography on the deposition of this unit. Rocks are presumed to dip NE (grid E) on the Puck grid and to dip N (grid N) on the Toe grid. Steeply dipping normal faults oblique to the local strike are known to be present.

Economic mineralization encountered to date occurs in a 1 to 15 m thick massive sulphide horizon south of Wolverine Lake. The Wolverine and Lynx zones appear to be separate 'puddles' in a larger (500 m by 700 m) massive sulphide deposit. Footwall stringer mineralization consists of chalcopyrite, pyrrhotite, pyrite and lesser galena-sphalerite in a strong zone of chlorite alteration and is most intense in a paleotopographic high between the two deposits. This may be the original source vent. At depth, the chlorite alteration grades into intense sericite alteration. The massive sulphide layer consists of >80% pyrite-sphalerite-chalcopyrite-pyrrhotite-galena and lesser tetrahedrite in bedded layers with local interbeds of graphitic argillite. The massive sulphide layer is capped by a hanging wall tuffaceous graphitic argillite. Approximately 30 m above the deposit is a calcite-pyrite exhalative unit containing 5-20% fine grain pyrite-pyrrhotite-chalcopyrite-galena in wispy bands.

3.1 Physical properties of rock units

Measurements of electrical resistivity and magnetic susceptibility were taken on selected core samples from DDH WOLV-95-20. Magnetic susceptibility was measured with an Exploranium KT-9 susceptibility meter and electrical resistivity was measured both wet and dry using standard DC methods described in Telford *et. al.* (1990). Results are tabulated below:

DESCRIPTION	MAGNETIC SUSCEPTIBILITY (SI UNITS X 10 ⁻³)	ELECTRICAL RESISTIVITY (OHM-M)
Footwall rhyolite	-0.01	>2530
Massive sulphides: massive py-ga-sp±cpy, banded, > 80% sulphides (272 m)	0.01 - 0.23 (avg 0.03)	22 (dry) 1.8 (wet)
Massive sulphides: heavily disseminated (50%) py-cpy-sph with quartz and chlorite (273 m)	-0.05 to 0.09	210 (dry/wet)
Massive sulphides: cpy-pyr-po in massive bedded sulphide folded parallel to core axis. Possible stringer zone mineralization (275 m)	43	3.6 (dry) 1.4 (wet)
Hanging wall argillite: black, soft graphitic argillite (268 m)	-0.01	44 (dry) 35 (wet)
Hanging wall argillite: as above but not as soft and less graphite (266m)	-0.04	319 (dry) 210 (wet)

This limited suite of measurements suggests the following:

1. The massive sulphide horizon is an excellent electrical conductor and the

rocks show some magnetic susceptibility. Chalcopyrite rich lower massive sulphide bands carrying pyrrhotite are magnetically susceptible while the more zinc-rich upper massive sulphide bands show little or no magnetic susceptibility.

2. The hanging wall black argillite is locally quite conductive but not uniformly so. Highly graphitic intervals are quite conductive but much of the argillite horizon is only slightly conductive. These remarks would probably also apply to the footwall argillite which this unit resembles.

3. The underlying rhyolites and probably those overlying the deposit are not conductive nor are they magnetically susceptible.

4.0 HLEM AND MAGNETIC FIELD INTERPRETATION PROCEDURES

A brief summary of the HLEM method is contained in Appendix D. The data were interpreted using standard plate models appropriate to the geological framework discussed above. The following notes summarize important aspects of the interpretation:

1. Anomalous responses and conductor axis locations were taken from the 1760 Hz data. Some of these anomalies have no response at lower frequencies because of their low conductance.
2. Conductors were interpreted as dipping thin-plate responses conformable with the geology and conductor axes indicate the horizontal projection of the conductor apexes. There were no responses which could be realistically interpreted as arising from compact (eg. sub-spherical) or flat-lying conductors.
3. Some responses show excess width in the response (ie. greater than 100 m between zero base level cross-overs in the trough of the HLEM anomaly). This is often an indicator of significant conductor width and the excess width can be used to estimate the thickness of the conductor. This excess width is prone to error, particularly in the case of weak responses. Excess width is indicated in metres on the lower right hand side of the anomaly symbols. Where the response width of the conductor was very wide, the horizontal projections of the top of the conductor were indicated by stippling in the diagram.
4. Conductance symbols show the conductor parameters interpreted at 1760 Hz. Indicated response width is the lesser of the IP and Q response widths where they differ. Depth to top is primarily determined from the response amplitude; this may be increased by current channelling in conductive

overburden producing underestimations of conductor depth. Conductive overburden would be indicated by high positive IP and Q responses at 3520 Hz in areas flanking the conductor response. Massive sulphide conductors show target conductances varying from 1 to 40 Siemens, depending upon the mineralogy. Massive sulphide horizons with heavy concentrations of chalcopyrite and pyrrhotite have high conductances while assemblages with abundant galena-sphalerite-pyrite show lower conductances. Zinc-rich conductors are at the lower limit of the quoted conductance range. Graphite beds show discrete target conductances in the range expected for massive sulphides.

5. Conductance is derived from the ratio of the IP to Q which, when plotted on characteristic curves permits, the determination of a response parameter. The response parameter in turn, can be decomposed to produce a conductance estimate (conductivity thickness product). The response parameter is the product of the conductor's magnetic susceptibility, conductivity and thickness, the operating frequency and the coil spacing. The change in IP/Q versus the change in response parameter is often used to determine the nature of a conductor. Conductors which are inductively thick (ie. greater than one skin depth) show a drop off in IP/Q with increasing response parameter. Most conductive massive sulphide horizons are inductively thick because their skin depth is only a few metres. Other geological targets, with the possible exception of very conductive graphite, are inductively thin. Plots of IP/Q versus response parameter show a linear trend in the case of inductively thin targets. IP/Q versus response parameter plots were made for several intersections where there were interpretable responses at 440 through 3520 Hz. These are contained in Appendix C.

6. Dips were not estimated from the HLEM data because the interference between conductors distorted the shape of the flanking positive anomalies. The ratio of the height of the larger peak to the smaller peak is used to determine the dip of the conductor; if this is distorted by a nearby conductor or by footwall or hanging wall conductivity, the dip estimate will be in error.

Magnetic field anomaly interpretation was assisted by running forward models with REVS, a potential field forward modelling program developed by Geopak Systems Ltd. The response of the most plausible stratabound source body - an extensive magnetite sheet representing an exhalite horizon - was examined to guide subsequent interpretation. An example of the output modelled specifically for the nearby Puck Property is shown in Figure 1; the results are also applicable to the survey on the Toe Property. The diagram shows the response of a magnetic sheet dipping at 45° and striking grid N in the local magnetic field encountered on the Puck property. Two model responses are shown; one for a shallow source and the other for a source

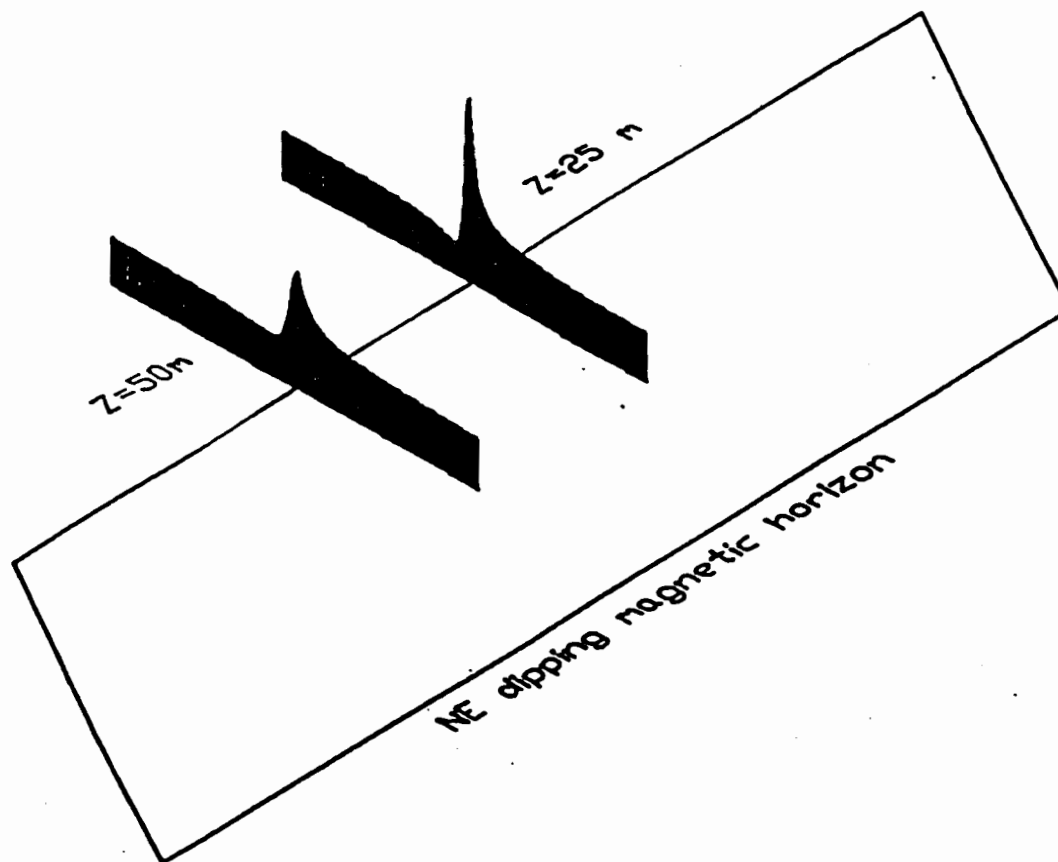

Figure 1. Forward model of total magnetic field response of a dipping magnetic dike in the magnetic field at the Puck property. Magnetic field parameters: Declination 30° inclination 75° , field intensity 58400 nT (International Geomagnetic Reference Field). Body parameters: Strike 143° , dip 50° NE, thickness 5 m, length 5000 m, depth extent 1000 m, magnetic susceptibility 10×10^{-3} SI units. Data is from a profile at right angles to the target over the centre of the target. Maximum amplitude is 162 nT.

buried by 50 m of overburden. The results demonstrate that the response of a dipping magnetic horizon consists of an asymmetric high centred over the target apex with a trough on the SW side of the anomaly and a declining positive response on the NE side of the target.

5.0 DATA PRESENTATION AND FORMATS

Digital data is appended to this report in ASCII XYZ format. Each file has a header on the first line showing the data contained in the columns beneath. For the magnetic field data, the common format is:

```
Line Station X Y Corr_mag
```

For the HLEM data, the common format is:

```
Line Station X Y 440IP 440Q 880IP 880Q 1760IP 1760Q 3520IP 3520Q
```

Corr_mag denote total magnetic field data corrected for diurnal variation. xxxIP and xxxQ denotes in-phase and quadrature components at the prefixing frequency in percent of the vertical primary magnetic field (H_z) corrected for terrain effect.

HLEM data is displayed in stacked profile plots showing the survey grid and the in-phase and quadrature readings as solid and dashed line profiles. The zero level on each profile is coincident with the survey line and the direction of the positive response is shown diagrammatically in the legend. A scale of 20% H_z per cm was used in the plotting. Along the grid lines, the small tick marks show the station locations and every 100 m is indicated by a larger tick. Conductors of interest are indicated with symbols at each intersection. All anomalies were interpreted as thin tabular conductors unless otherwise indicated. Conductor axes formed by linking similar line-to-line responses are indicated by thick lines.

Total magnetic field data is displayed in colour contoured maps. These show the locations of the grid lines, marked in the same fashion as in the HLEM plots and contoured values of the total magnetic field. Superimposed on this is a full colour contour plot and any HLEM conductor axes.

6.0 RESULTS

Copies of the digital data are appended to this report in the standard format. Plots of the data collected are contained in the back pockets of this report. The following figures display the data collected on this property:

Figure	Location	Description
TO-1	Pocket	Maxmin I-10 / 440 Hz - 100 m coils stacked profiles
TO-2	Pocket	Maxmin I-10 / 880 Hz - 100 m coils stacked profiles
TO-3	Pocket	Maxmin I-10 / 1760 Hz - 100 m coils stacked profiles
TO-4	Pocket	Maxmin I-10 / 3520 Hz - 100 m coils stacked profiles
TO-5	Pocket	Total magnetic field with HLEM anomalies.

In-phase HLEM noise levels at 440 Hz are estimated at $\pm 1\%$ H_z based on measurements of station-to-station excursions from average base level in quiet areas. The noise level on the 3520 Hz plots rises to $\pm 2\%$ H_z and includes the effect of conductive overburden. Total magnetic field noise levels were estimated using a similar procedure from a stacked profile plot and appear to be ± 20 nT. The magnetic noise levels reflect the presence of near surface magnetic material and are well above the instrument noise levels.

Available geological data from four drill holes and geological observations made by the field crew indicate that rock units on the grid are generally oriented at 310° 40 - 60° NE and that graphitic argillite, sericite schist and a porphyritic unit are present. Thick sections of graphitic argillite were intersected in DDH TO-96-03 and were observed in limited outcrop on the north and central portions of the grid. The inferred strike of the geology correlates well with the general trend of the total magnetic field data. The magnetic field data was trend rotated to 300° and contoured using a 20 m grid cell interval to produce contours aligned with the obvious strike of the magnetic field data. Lows or highs not intersected by survey lines are likely splining artifacts and should be disregarded.

Eleven HLEM conductors were identified in the data set and detailed descriptions of interpreted target parameters are tabulated in Appendix B. The responses appear to be caused by moderate to steeply dipping tabular structures of variable width. Conductor trends are within 20° of the general trend of the magnetic data and the conductors appear to be conformable or at least stratabound. Portions of **TO-3** and **TO-11** are notable exceptions.

The following conductors appear to be graphitic argillite beds:

TO-2
TO-5 (L8900E-9300E and L10100E-10500E)
TO-6
TO-9
TO-10

These conductors follow magnetic field lows, show high apparent conductances and in some cases, wide to very wide apparent conductor widths. Conductor **TO-6** has been confirmed as a graphitic argillite bed by drilling (DDH TO-96-03). Plots of IP/Q versus response parameter show weakly divergent trends indicating inductive thickness at **TO-6** intersections L10100E / 10875N and L8500E / 11275N but in both cases, the conductor has a large response width which may account for this phenomenon.

The following conductors appear to be of immediate interest:

TO-1 L10500E 11500N
TO-11 L7100E 11000N

and the trend formed by:

TO-5 L9500E 11225N
 L9700E 11125N
 L9900E 11075N

TO-6 L10100E 10875N

These conductors are 0 to 50 m SW (ie. stratigraphically beneath) magnetic field highs, have target conductances in the range expected for massive sulphides and have narrow widths. A plot of IP/Q versus conductance for the **TO-5** intersection L 9500E / 11225N is weakly divergent indicating possible inductive thickness. This may indicate the presence of massive sulphides because the apparent width of the target is negligible and any inductive thickness must be caused by conductive rocks alone.

There are no HLEM anomalies associated with the 900 nT positive magnetic anomaly centred at L9300E / 10650N. This suggests that the source of this anomaly is probably magnetite.

7.0 CONCLUSIONS

The results of the surveys on the Toe grid suggest the following conclusions:

- a. The general trend of the stratigraphy is approximately 300° and there is no indication of a laterally extensive magnetite exhalite horizon similar to those found on the properties to the southeast.
- b. Conductors **TO-2, 6, 9, 10** and portions of **TO-5** are probably graphitic argillite based on their conductance, low magnetic response and, in some cases, wide response widths.
- c. Conductors **TO-1, 11** and portions of **TO-5** and **TO-6** have responses similar to those expected from massive sulphide conductors in this area. The HLEM responses are closely associated with a weak magnetic field high, have narrow target widths and high target conductances. IP/Q versus conductance behaviour of one intersection on **TO-5** indicate that this narrow target is inductively thick and consequently may be massive sulphides.

8.0 RECOMMENDATIONS

Conductors **TO-1, 5, 6** and **TO-11** should be tested by drilling if supporting geochemical and geological information so dictates.

Respectfully submitted
AMEROK GEOSCIENCES LTD.



M. A. Power M.Sc. P.Ge.
Geophysicist

August 7, 1997

REFERENCES CITED

- Mortensen, J.K. and G.A. Jilson (1985) Evolution of the Yukon-Tanana terrane: Evidence from the southeastern Yukon Territory. in: *Geology* Vol 13 p806-810.
- Telford, W.M., L.P. Geldart and R.E. Sheriff (1990) Applied Geophysics (2nd Edition) New York: Cambridge University Press.
- Ketola, M. and M. Puranen (1967) Type curves for the interpretation of Slingram (horizontal loop) anomalies over tabular bodies. Geological Survey of Finland Report of Investigations No. 1.
- Varre, T. (1990) Apex Parametrics Maxmin I-9 manual. Uxbridge: Apex Parametrics.

APPENDIX A. CERTIFICATE

I, Michael Allan Power, M.Sc. P.Geo., with business and residence addresses in Whitehorse, Yukon Territory do hereby certify that:

1. I am a member of the Association of Professional Engineers and Geoscientists of British Columbia (registration number 21131) and licensed as a Professional Geophysicist by the Northwest Territories Association of Professional Engineers, Geologists and Geophysicists.
2. I am a graduate of the University of Alberta with a B.Sc. (Honours) degree in Geology obtained in 1986 and a M.Sc. in Geophysics obtained in 1988.
3. I have been actively involved in mineral exploration in the Northern Cordillera since 1988 and am familiar with the Wolf Lake and Finlayson Lake areas.
4. I conducted the geophysical surveys described in this report.

Dated this 7th day of August, 1997 in Whitehorse, Yukon.

Respectfully submitted,



Michael A. Power M.Sc. P.Geo.

APPENDIX B. ANOMALY LISTINGS

Anomaly TO-1

Apex Location	Depth to top (m)	Dip / Dip direction	Excess Width (m)	Conductance (S)
L10500E 11500E	15	N/I	28	>>22
L10300E 11650E	<10	N/I	26	3.6

Anomaly TO-2

Apex Location	Depth to top (m)	Dip / Dip direction	Excess Width (m)	Conductance (S)
L9900E 12000N	33	N/I	32	>>30
L9700E 12025N	10	N/I	0	3
L9500E 12275N	30	N/I	0	8.7
L9300E 12375N	18	N/I	0	>22

Anomaly TO-3

Apex Location	Depth to top (m)	Dip / Dip direction	Excess Width (m)	Conductance (S)
L10500E 11150N	<10	N/I	42/29	2.9
L10300E 11350N	<10	N/I	0	2.6
L10300E 11225N	<10	N/I	0	0.5
L10100E 11575N	<10	N/I	0	3.6
L10100E 11475N	<10	N/I	0	3.6
L9900E 11700N	27	N/I	0	14.1
L9700E 11825N	10	N/I	50/76	3.1
L9500E 12025N	13	N/I	12/90	8.5
L9300E 12200N	<10	N/I	40/62	9.4

Anomaly TO-4

Apex Location	Depth to top (m)	Dip / Dip direction	Excess Width (m)	Conductance (S)
L9900E 11300N	60	N/I	102	8.8
L9700E 11450N	<10	N/I	12	6.48

L9500E 11550N	10	N/I	66/62	>22
L9300E 11625N	<10	N/I	42	3.6

Anomaly TO-5

Apex Location	Depth to top (m)	Dip / Dip direction	Excess Width (m)	Conductance (S)
L10500E 10925N	<10	N/I	112	9.4
L10300E 11050N	10	N/I	88/104	6.5
L10100E 11125N	12	N/I	100	8.5
L9900E 11075N	<10	N/I	0	3.5
L9700E 11125N	17	N/I	0	11.51
L9500E 11225N	13	N/I	0	9.5
L9300E 11325N	12	N/I	0	4.4
L9100E 11375N	15	N/I	0	13.1
L8900E 11400N	<10	N/I	0	0.7

Anomaly TO-6

Apex Location	Depth to top (m)	Dip / Dip direction	Excess Width (m)	Conductance (S)
L10300E 10775N	14	N/I	4/96	3.9
L10100E 10875N	<10	N/I	22	4.5
L9900E 10950N	<10	N/I	0	8.6
L9900E 10800N	<10	N/I	0	8.3
L9700E 11000N	<10	N/I	0	3.6
L9700E 10875N	<10	N/I	0	4.5
L9500E 11075N	10	N/I	0	8.8
L9500E 10925N	<10	N/I	0	13.2
L9300E 10950N	<10	N/I	0	8.5
L9300E 10925N	10	N/I	0	9.4
L9100E 11125N	<10	N/I	0	8.4
L9100E 11025N	13	N/I	0	4.5
L8900E 11200N	10	N/I	0	8.6
L8900E 11100N	<10	N/I	0	3

L8700E 11225N	12	N/I	52/86	8.7
L8500E 11275N	10	N/I	42	8.4
L8300E 11325N	10	N/I	0	8.4

Anomaly TO-7

Apex Location	Depth to top (m)	Dip / Dip direction	Excess Width (m)	Conductance (S)
L9100E 11450N	<10	N/I	0	2.6
L8900E 11625N	<10	N/I	0	2.6
L8900E 11525N	<10	N/I	0	2.5

Anomaly TO-8

Apex Location	Depth to top (m)	Dip / Dip direction	Excess Width (m)	Conductance (S)
L9500E 11800N	10	N/I	/32	1.3
L9300E 11900N	10	N/I	12/20	14

Anomaly TO-9

Apex Location	Depth to top (m)	Dip / Dip direction	Excess Width (m)	Conductance (S)
L6700E 10663N	16	N/I	0	3.0

Anomaly TO-10

Apex Location	Depth to top (m)	Dip / Dip direction	Excess Width (m)	Conductance (S)
L6700E 11450N	15	N/I	0	3.6
L6900E 11325N	30	N/I	0	7.2

Anomaly TO-11

Apex Location	Depth to top (m)	Dip / Dip direction	Excess Width (m)	Conductance (S)
L7100E 11000N	25	N/I	0	3.0
L6900E 11175N	25	N/I	0	<1.2
L6700E 11300N	10	N/I	0	1.2

APPENDIX C. IP/Q VERSUS RESPONSE PARAMETER PLOTS

Inductive Thickness Plot

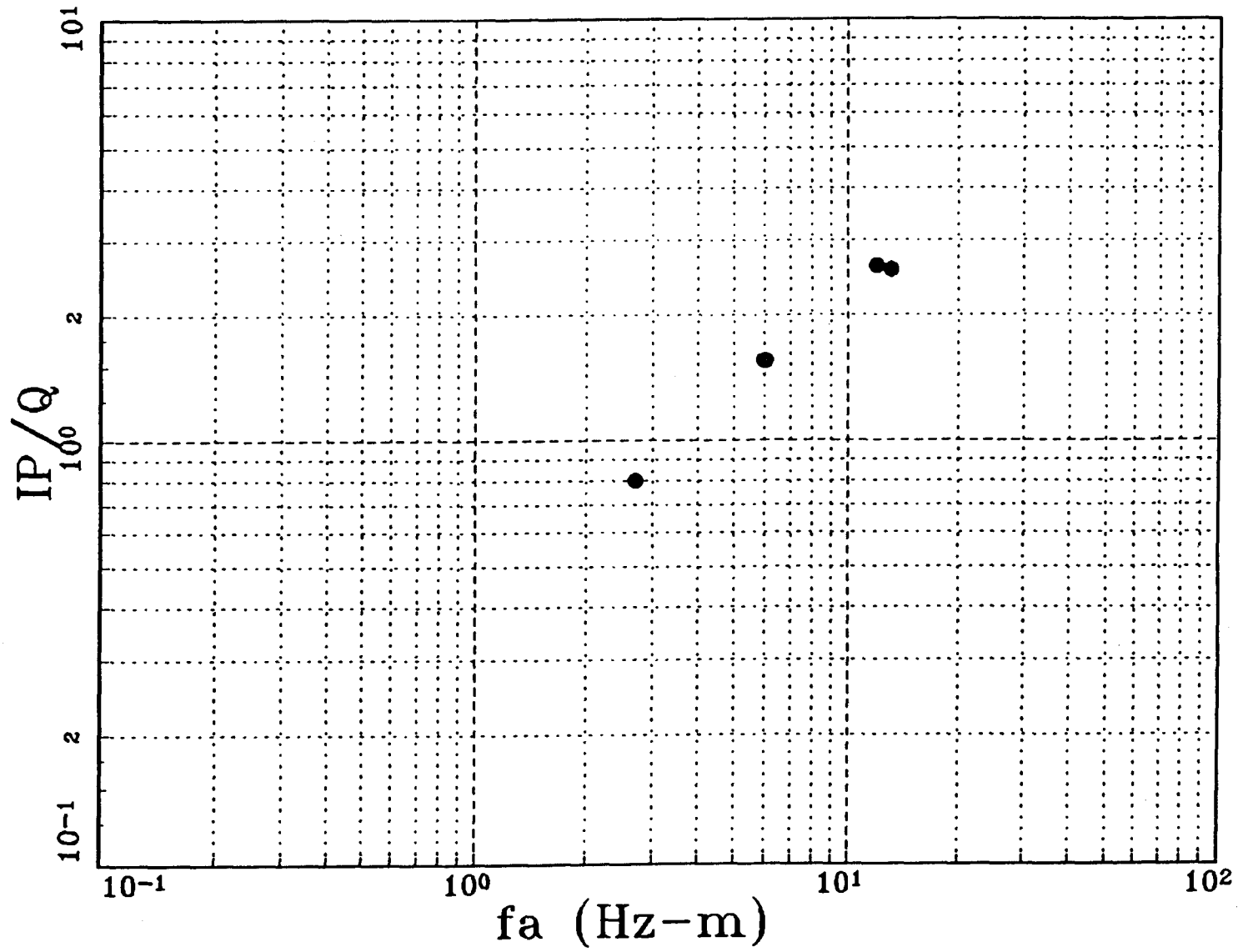

IP/Q versus response parameter plot for TO-3 at L9300E 12200N.

Inductive Thickness Plot

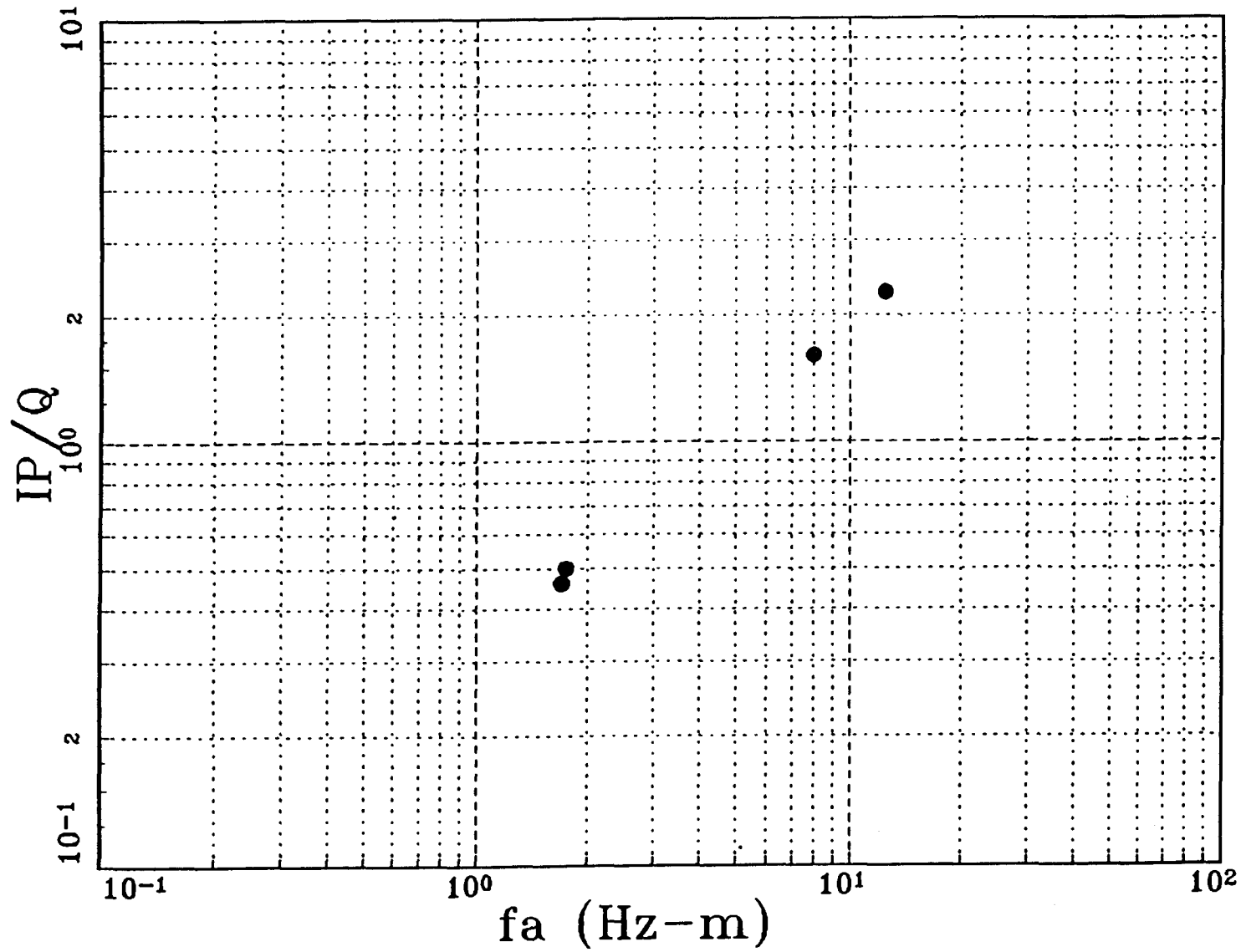

IP/Q versus response parameter plot for TO-3 at L9500E 12025N.

Inductive Thickness Plot

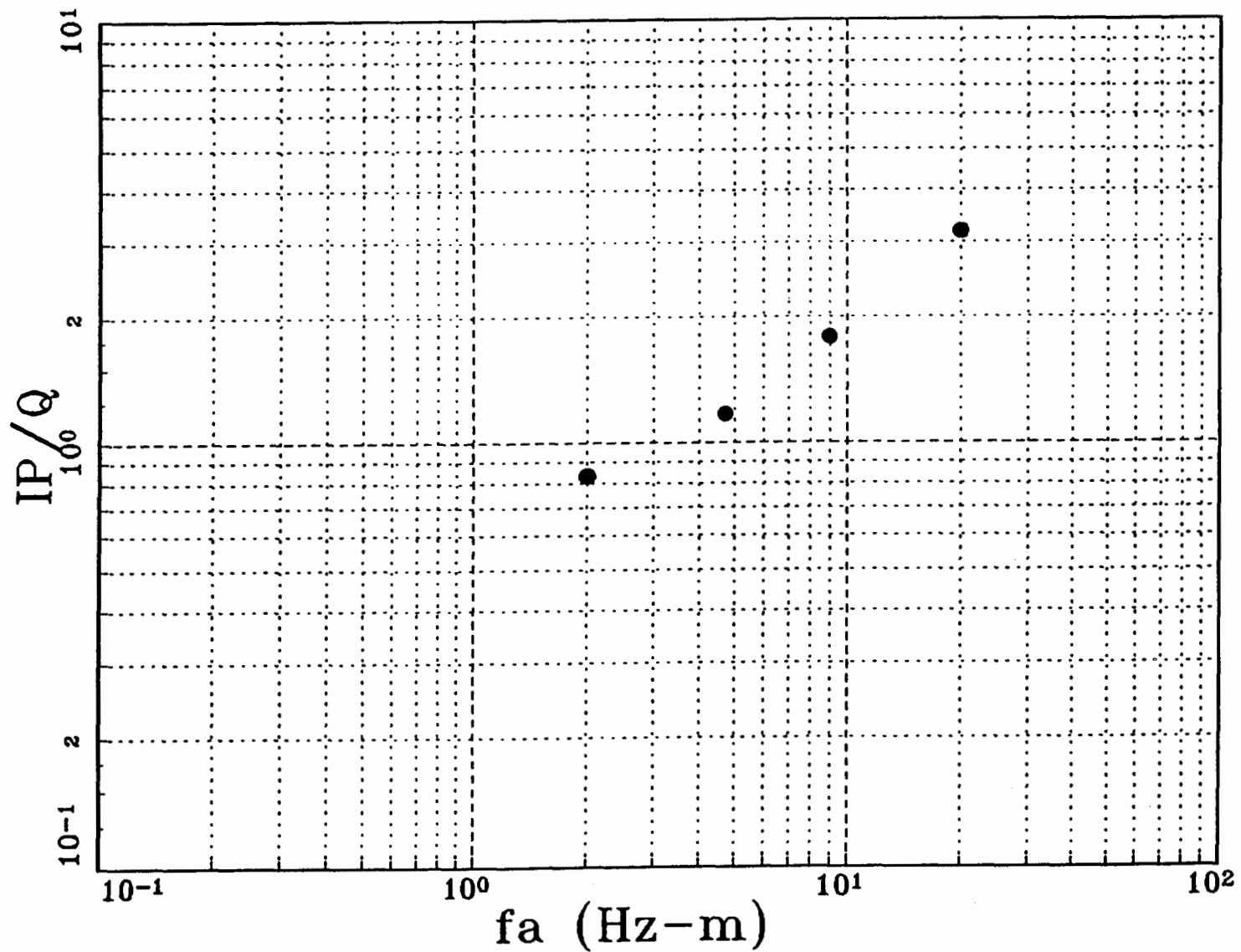

IP/Q versus response parameter plot for TO-4 at L9700E 11450N.

Inductive Thickness Plot

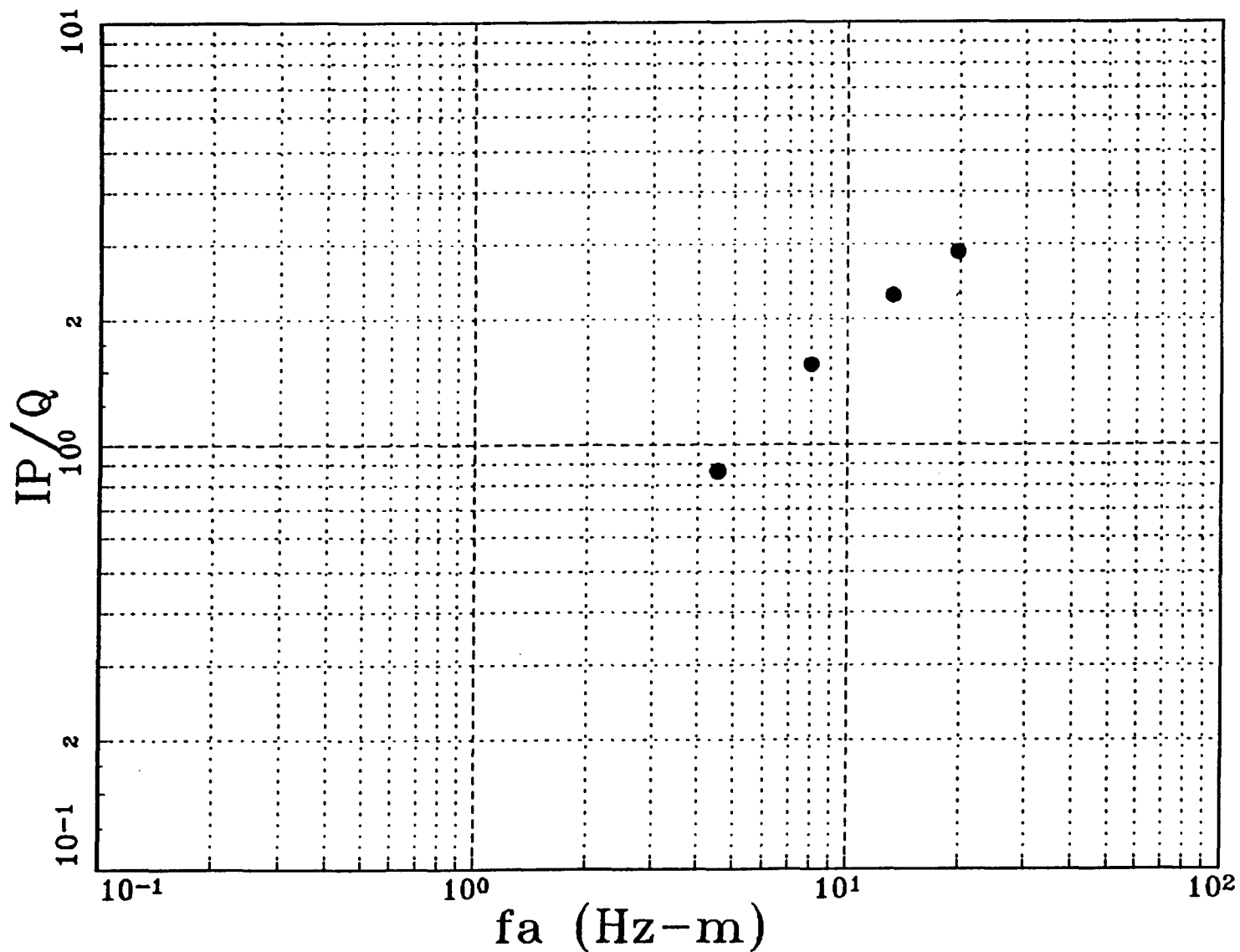

IP/Q versus response parameter plot for TO-5 at L9500E 11225N.

Inductive Thickness Plot

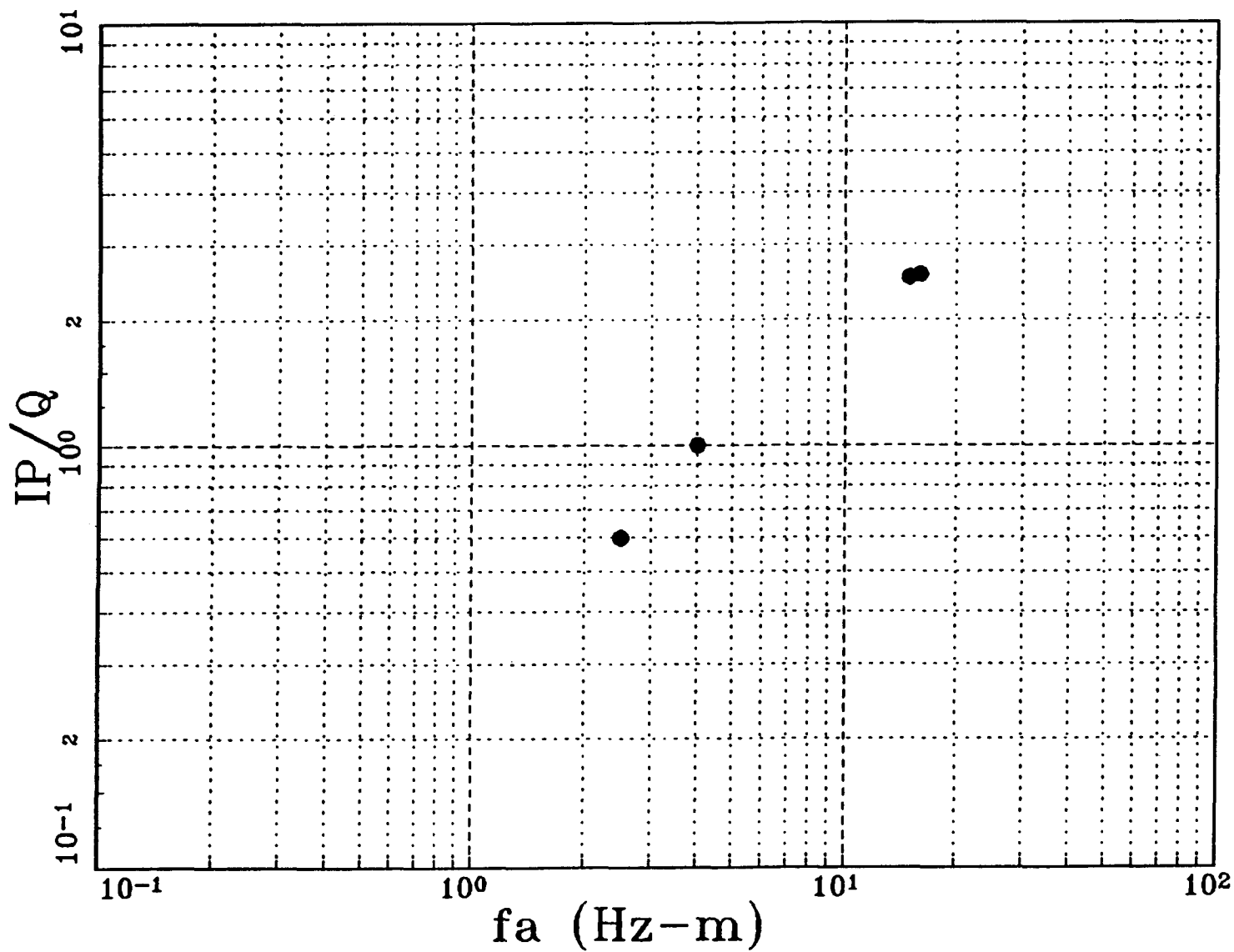

IP/Q versus response parameter plot for TO-5 at L9700E 11125N.

Inductive Thickness Plot

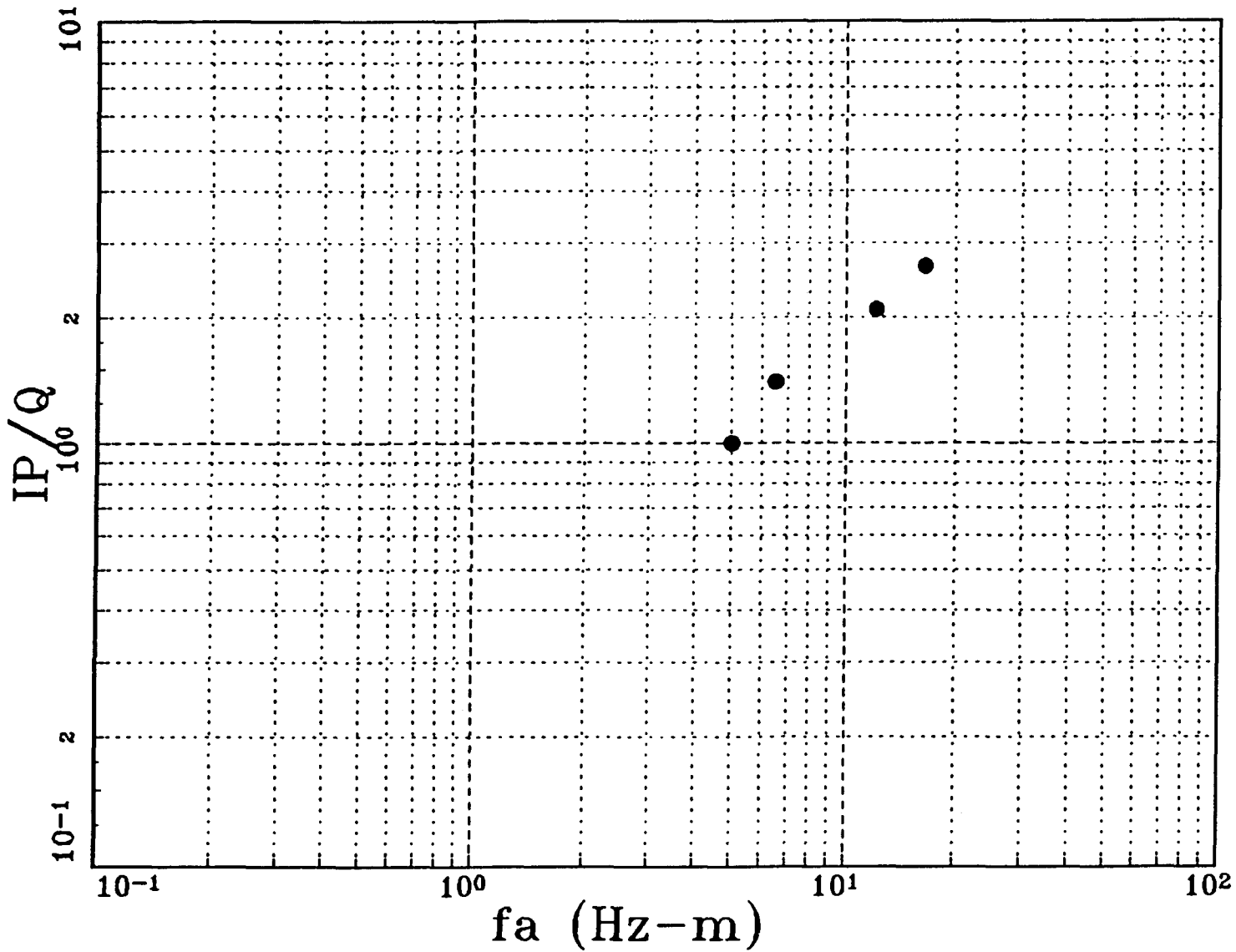

IP/Q versus response parameter plot for TO-6 at L8500E 11275N.

Inductive Thickness Plot

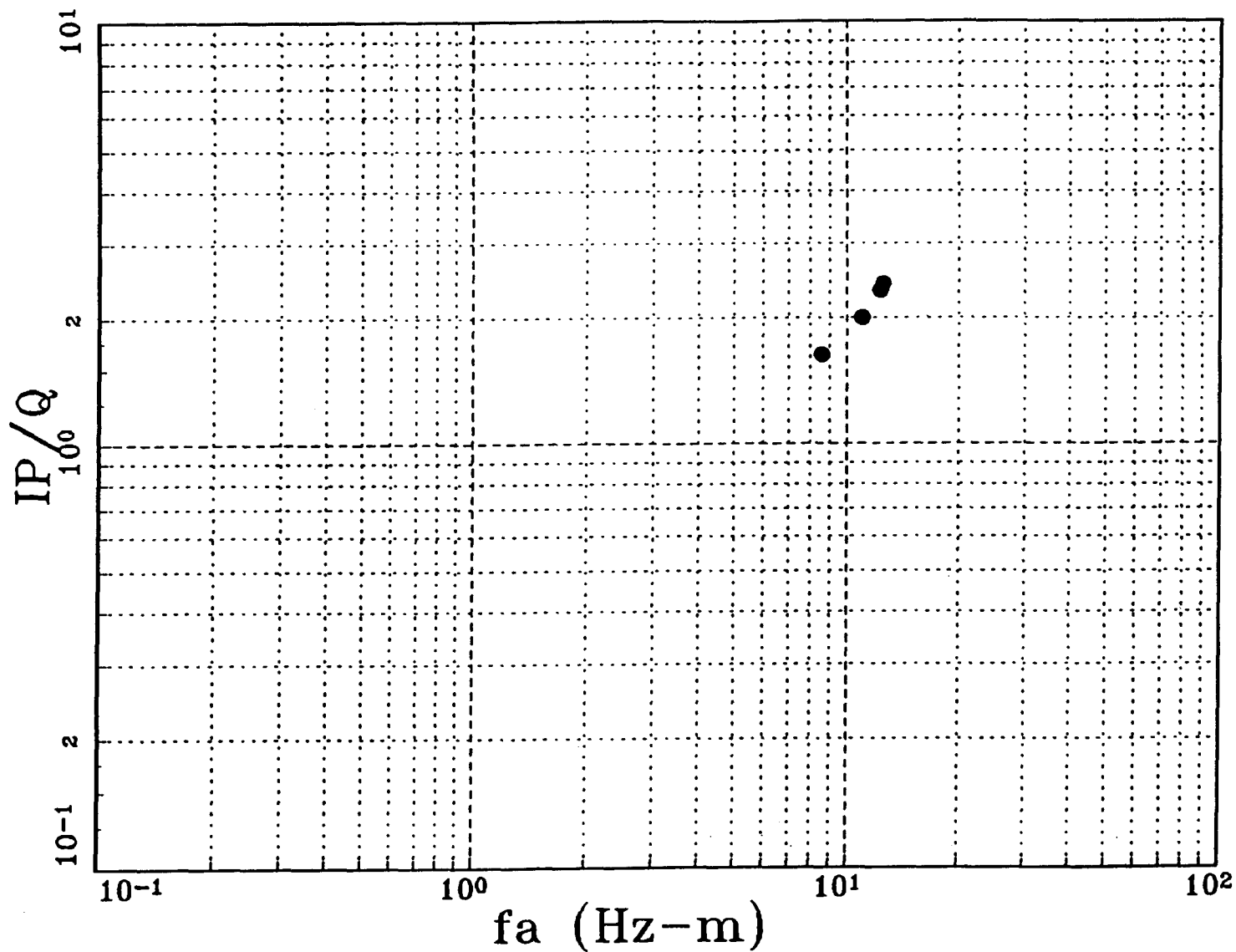

IP/Q versus response parameter plot for TO-6 at L8700E 11225N.

Inductive Thickness Plot

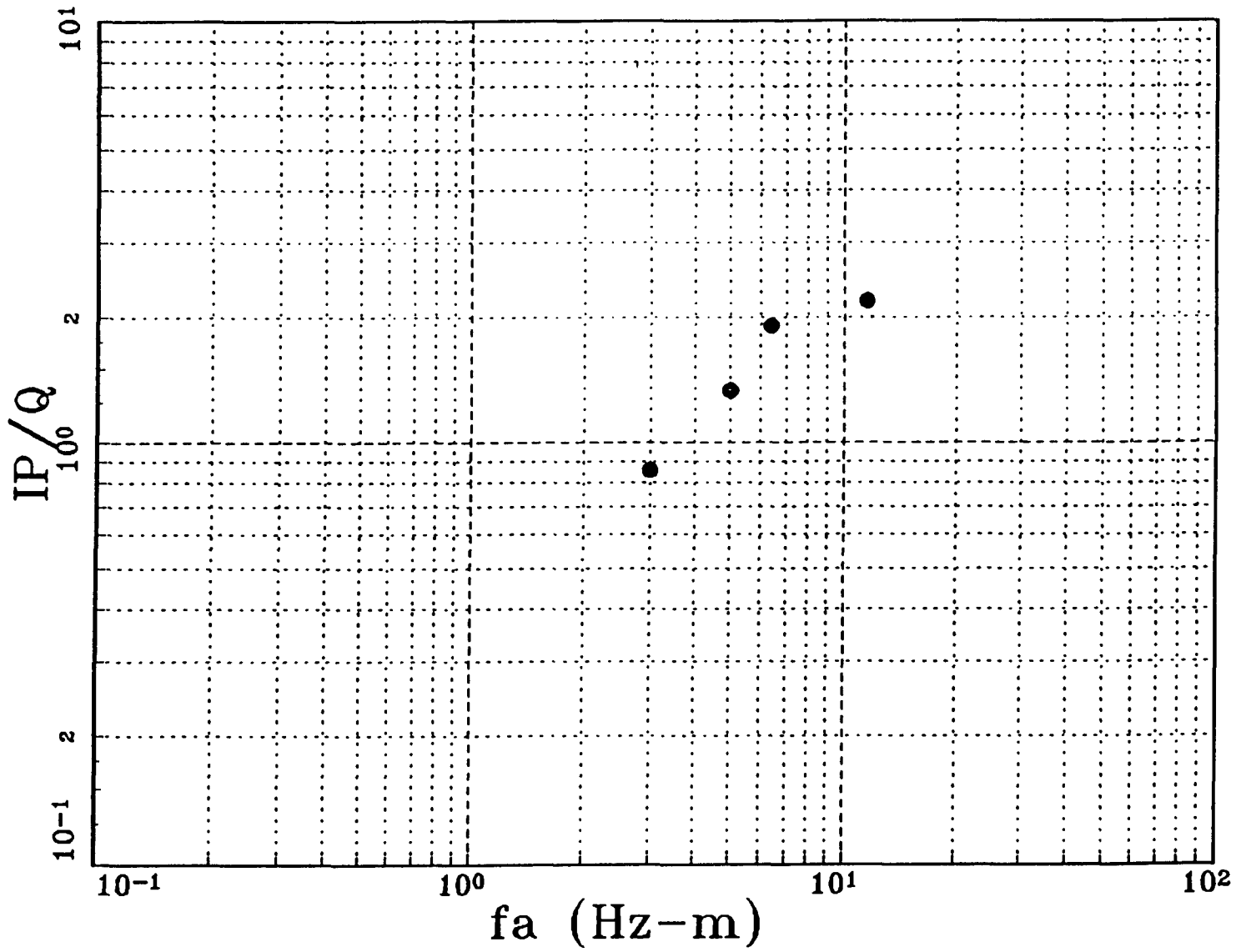

IP/Q versus response parameter plot for TO-6 at L10100E 10875N.

Inductive Thickness Plot

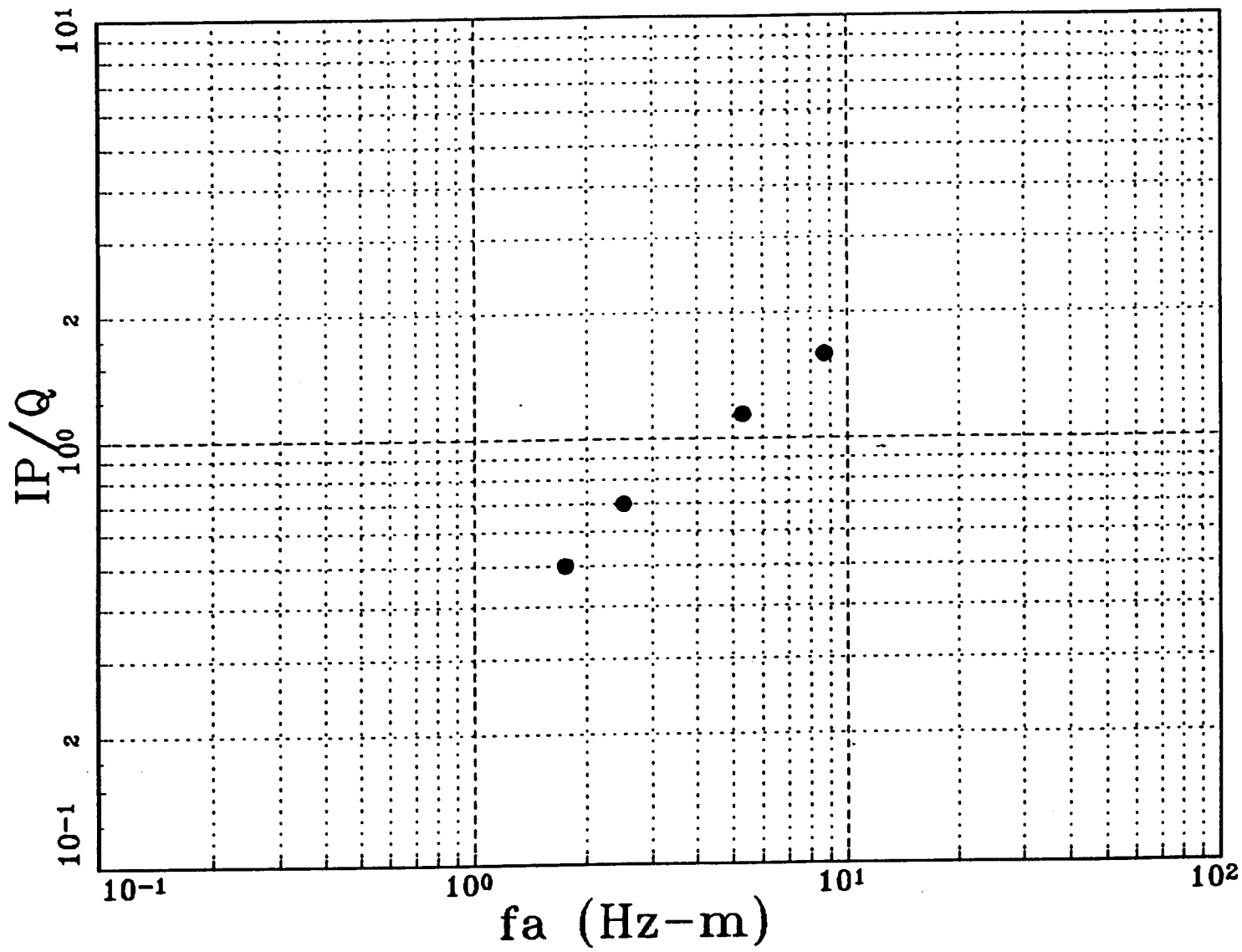

IP/Q versus response parameter plot for TO-6 at L10300E 10775N.

APPENDIX D. NOTES ON THE HLEM METHOD

The horizontal loop EM method is well described in standard texts such as Telford *et al.* (1990) and Ketola and Puranen (1967). This section summarizes the key features of the HLEM method and describes the interpretation algorithms used in this survey program.

The HLEM method involves the use of a pair of separated horizontal coils (Figure MM1). Most commonly, the surveys are conducted in the frequency domain. In this method, a sine wave of variable frequency is sent through one of the coils to create a time-varying vertical magnetic dipole source. The second coil is a receiver which detects both the primary signal from the transmitting coil and a secondary signal created by magnetic induction in a conductive target in the earth. There are two variants of the method in the frequency domain are the Slingram or conventional HLEM method and the Genie method.

The Slingram method (commonly referred to as HLEM) requires that a sample of the transmitted signal be sent along a wire to the receiver where it is used to synchronize the phase of the receiver with the transmitter. This permits the receiver to remove the effect of the transmitter signal (primary field) and to split the remaining secondary field into two components. One component represents the portion of the secondary field which is synchronized or in-phase with the primary field (in-phase component). The second component is the portion of the secondary field which lags the primary field by one quarter cycle (90°) (quadrature component). The ratio of the in-phase to quadrature components is used to determine the electrical conductance of a target.

HLEM instruments remove the primary field from the signal to leave only the secondary field. By convention, a secondary field in the same direction as the primary field is recorded as positive while a secondary field in the opposite direction to the primary field is recorded as negative. HLEM data is commonly plotted as profiles with the reading plotted at the midpoint between the transmitter and receiver. The reason for this is that the response from a steeply dipping conductor, the most common target of this method, is strongest when the two coils straddle the conductor. Normally, the in-phase response is plotted as a solid line and the quadrature response as a dashed line.

The HLEM response of a flat lying body is shown in Figure MM 2(a). Magnetic field lines (flux) are directed primarily into the region beneath the transmitter loop. Lenz's Law dictates that the induced secondary field will oppose the primary field. Consequently, at the receiver, both the primary and secondary field will be in the same direction. As a result, the response from a flat lying conductor consists of a

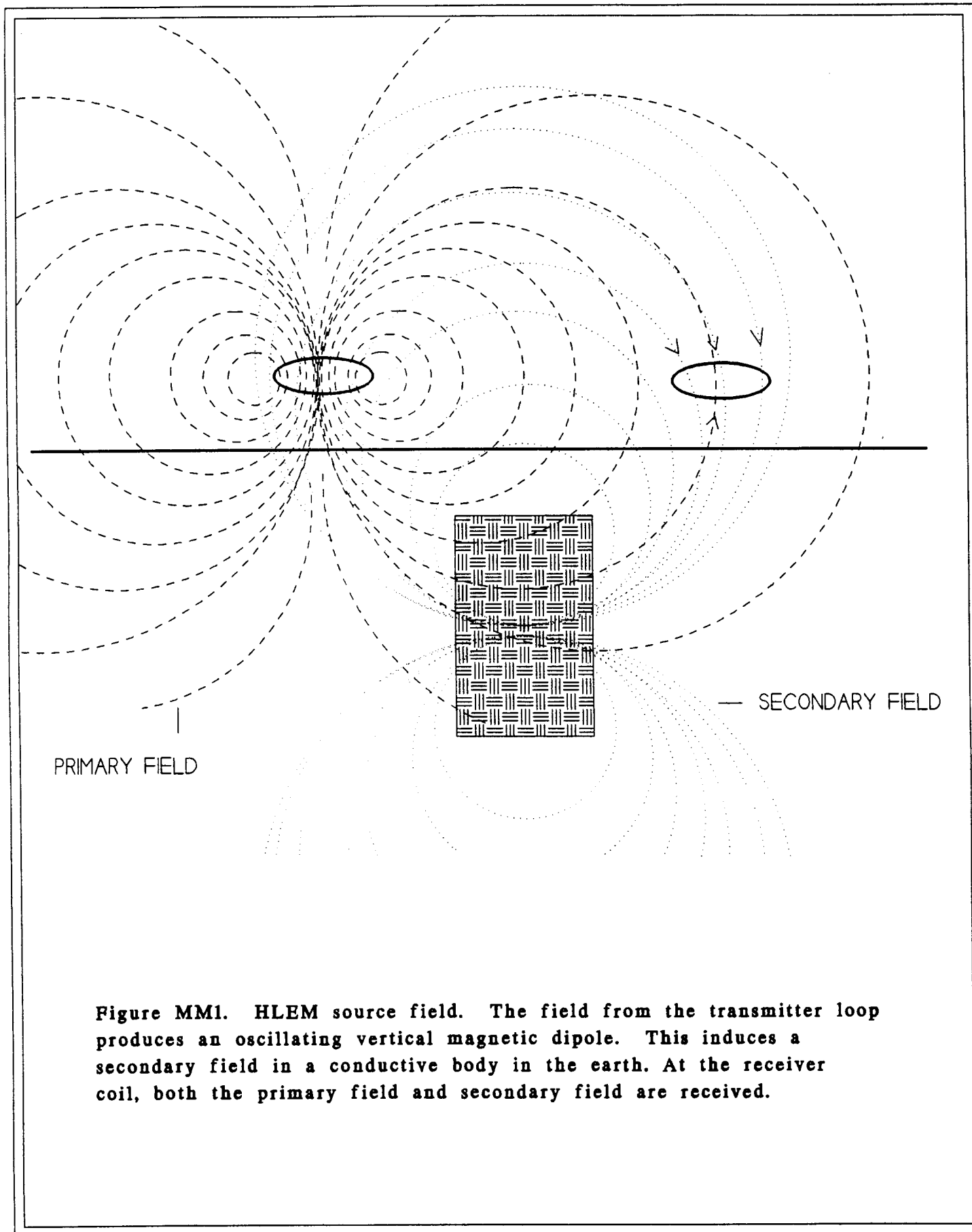

Figure MM1. HLEM source field. The field from the transmitter loop produces an oscillating vertical magnetic dipole. This induces a secondary field in a conductive body in the earth. At the receiver coil, both the primary field and secondary field are received.

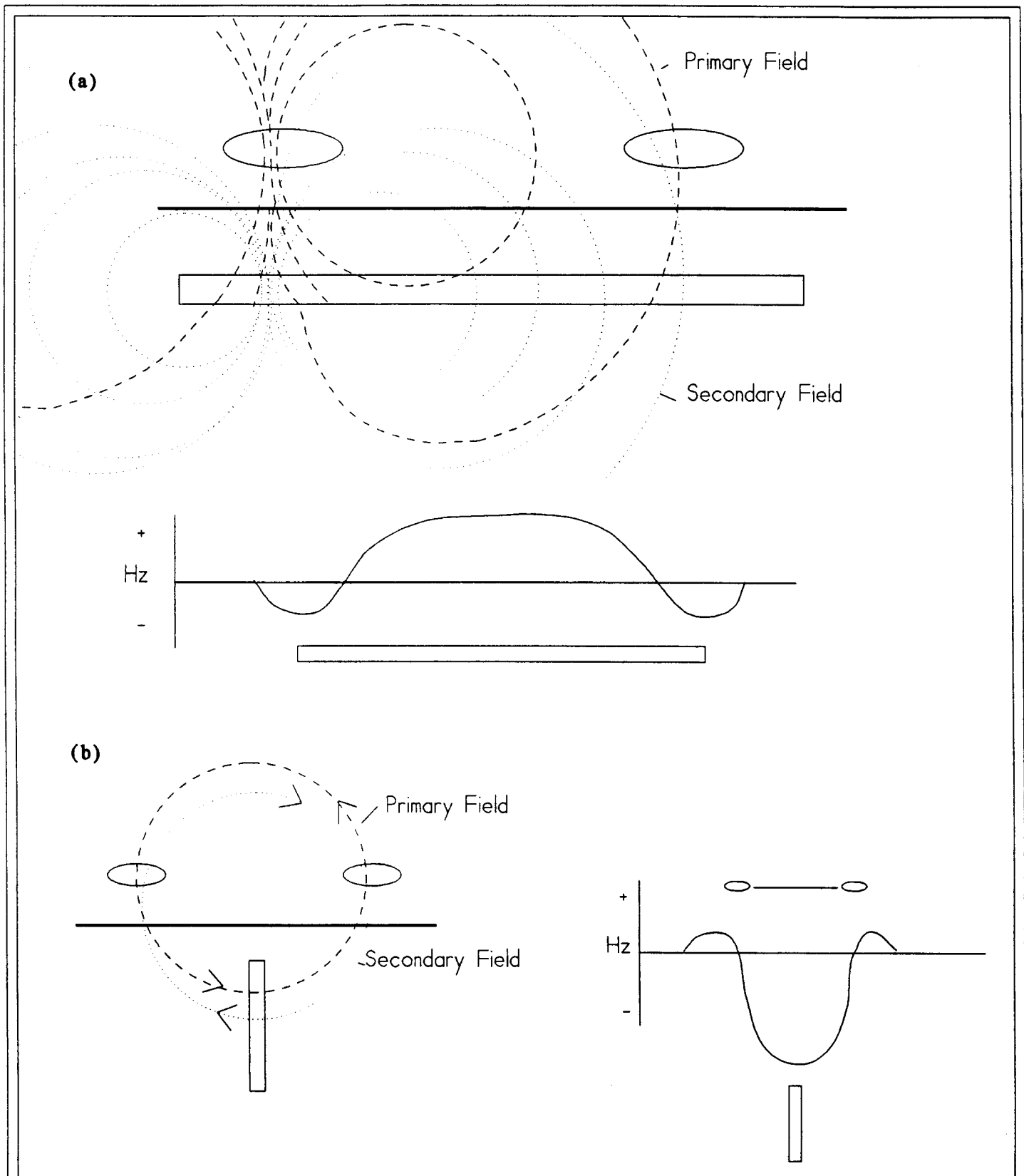
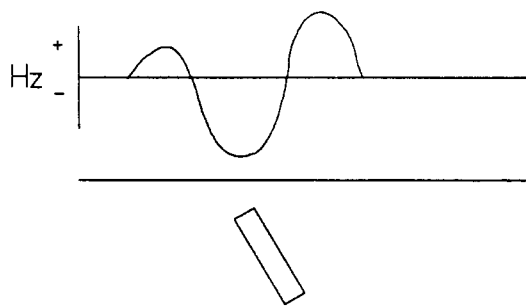
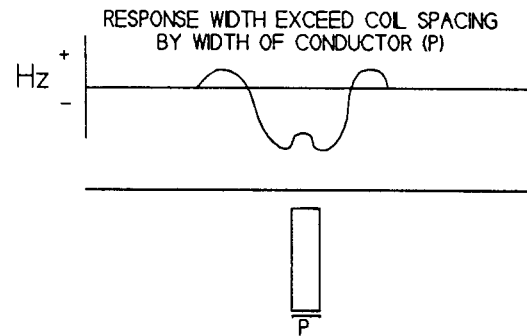

Figure MM2. HLEM responses. (a) Response over a flat-lying conductor consists of a positive response. (b) Response over a dipping conductor consists of a negative response.

(a)



(b)



(c)

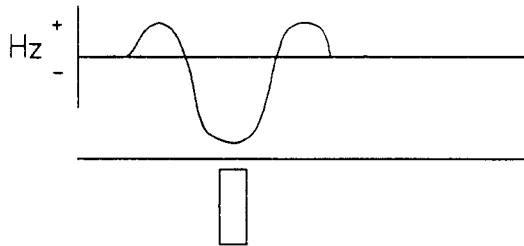

(d)

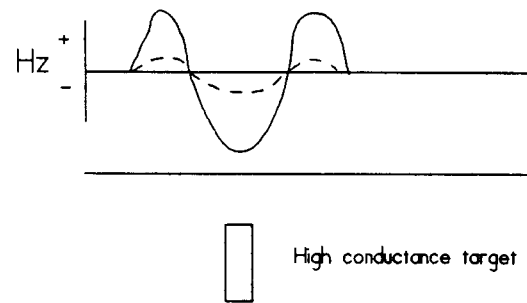
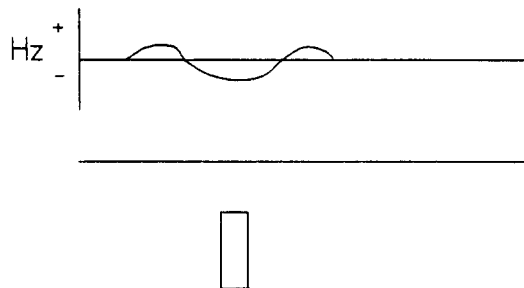
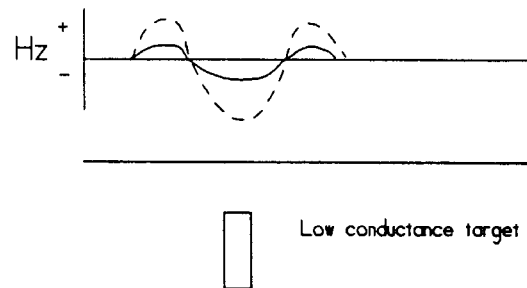

Figure MM3. HLEM response of dipping tabular conductors. (a) Effect of dip on HLEM response. (b) Effect of depth. (c) Effect of conductor width. (d) Effect of conductance.

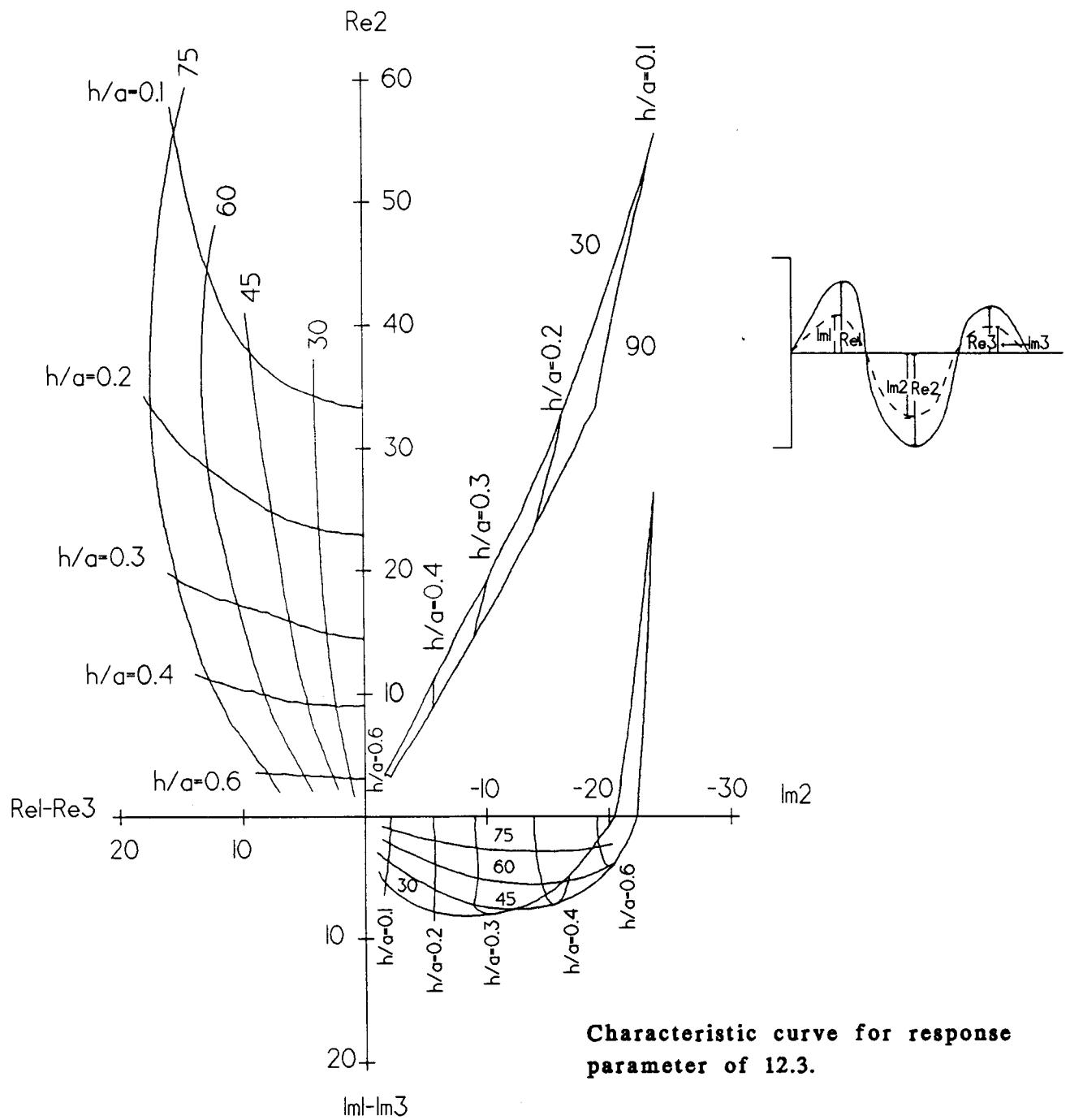

Figure MM4. Characteristic curve for a dipping tabular conductor from Ketola and Puranen (1967). Critical measurements of the response shown in the upper right are extracted and plotted to determine the geometry and conductance of the target.

positive response over the target. At the edge of the conductor, there is a negative response which occurs when both coils are straddling the edge of the conductor. When either the transmitter or receiver coil is over the edge of the conductor, there is no secondary field and the response is zero. As the depth to the flat lying conductor increases, the strength of the response is attenuated. The effective depth of investigation of the HLEM method for flat lying conductors is approximately 1.5 times the coil spacing.

The HLEM response of a steeply dipping conductor is shown in Figure MM2(b). Field lines from the transmitter are horizontal at a point midway between the two coils and in this orientation, cut the conductor at right angles creating the best coupling. Lenz's Law dictates that the secondary field will oppose the primary field and at the receiver coil, the secondary field is in the opposite direction to the primary field. As a result, the response when profiling over a steeply dipping conductor consists of a trough with peak negative value occurring when the coils straddle the conductor. The flanking positive peaks result from induction effects as the pair of coils are close to but not straddling the conductor. When either of the coils is directly over the target, the response is zero because the primary field is not well coupled with the target (ie it is perpendicular to the edge of the conductor) and little secondary field is created.

A dipping tabular conductor can be specified by the dip and dip direction, depth to top, target width and electrical conductance (conductivity thickness product or σt). The effect of varying these parameters is shown in Figure MM3 for the case of a response from a single isolated HLEM conductor. Asymmetry in the positive shoulders indicates the dip direction and the ratio of the positive shoulder responses can be used to estimate the dip (Figure MM3(a)). The strength of the response is largely determined by the depth to the top of the conductor. Increasing the depth to the top of the conductor decreases the amplitude of the response but does not otherwise change the shape of the response (Figure MM3(b)). The effective depth of investigation of the HLEM method for steeply dipping targets is approximately one half the coil spacing. If the conductor is wide, the location of the zero crossovers, normally equal to the coil spacing, will increase. If the width reaches approximately one half the coil spacing, the trough of the response for shallow targets will start to deflect slightly to the positive. If the width of the target approaches that of the coil spacing, the positive return in the trough will be apparent at any depth to target (Figure MM3(c)). As noted above, the electrical conductance controls the ratio of the in-phase to quadrature response. Weak targets show only a quadrature response. As the target conductance increases the strength of the in-phase component will increase. Very high conductance targets are characterized by strong in-phase responses and weak to very weak quadrature responses (Figure MM3(d)).

Interpretation procedures for HLEM data are dependent upon the model to which the data is to be fitted. In most cases, the characteristic shape of the response will dictate

the likely overall geometry of the source and thus the model to which the response should be fitted. Flat lying targets can be directly modelled with computerized calculations of target responses. Dipping tabular body responses on the other hand cannot be numerically modelled and must either be approximated through finite-element models or interpreted using characteristic curves. Characteristic curves for tabular dipping conductors incorporate several key features of the responses described in Figure 3 into simple charts. These responses are derived from model experiments. The ratio of positive shoulders responses and the ratio of in-phase to quadrature peak negative values are the commonly used features of the response. An example of these charts is shown in Figure MM4.

The data contained in this report was interpreted using characteristic curves developed by Ketola and Puranen (1967). The procedure, normally done by hand, has been automated in proprietary software (MMPLOT) developed by Amerok Geosciences Ltd. The characteristics of each response are entered into a computer program which creates a batch plotting file. The data is plotted directly on a CADD diagram with each of the characteristic curves on a different layer. The operator is able to quickly match the data to the curve which best fits the data by selecting different characteristic curves (ie. by changing layers). Where the data falls between two curves, the conductance and depth to top parameters can be interpolated but the dip cannot be reliably interpolated.

APPENDIX G

OVERSIZE FIGURES

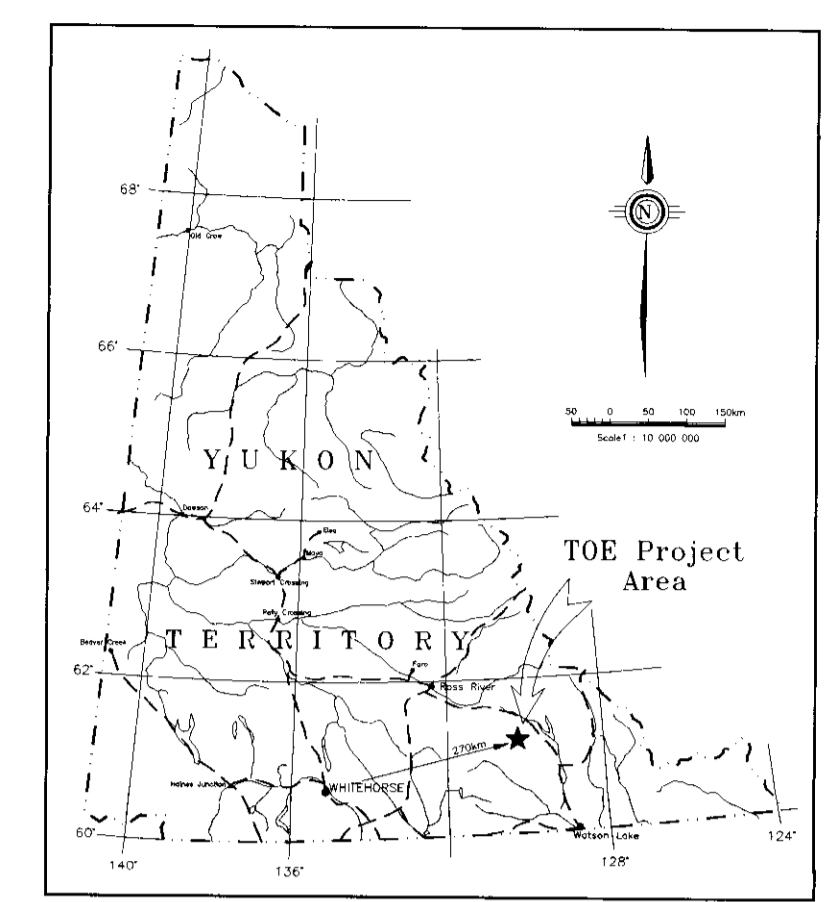
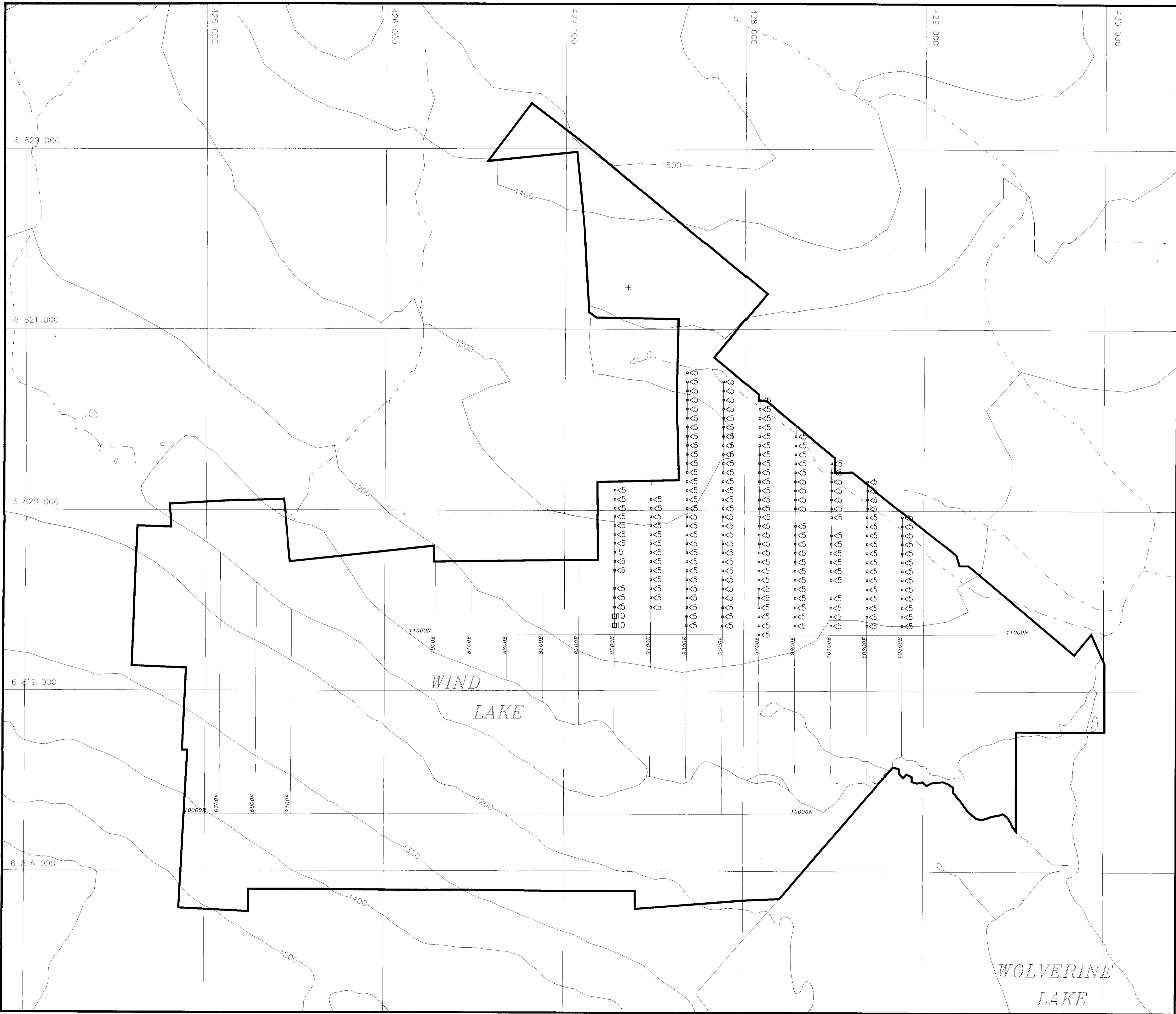

LOCATION MAP

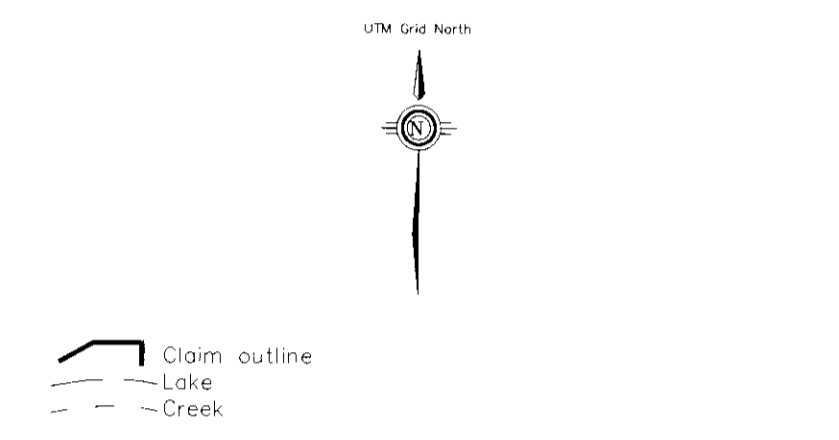

Au in Soil (in ppb)
 Max □ 10
 Min ◦ 2.5

093782
 Dag

WESTMIN		WESTMIN RESOURCES LIMITED ATNA RESOURCES LTD.	
Work By WESTMIN	TOE Property		
Date Drafted Dec. 12, 1996	Au in Soil (in ppb)		
Drafted By A.T. & J.K.			
Date Revised			
Revised By			
N.T.S. Number 105 G/8-9	200 0 200 400 600m		Figure 6.1
File Name TOE_C-97.DWG			

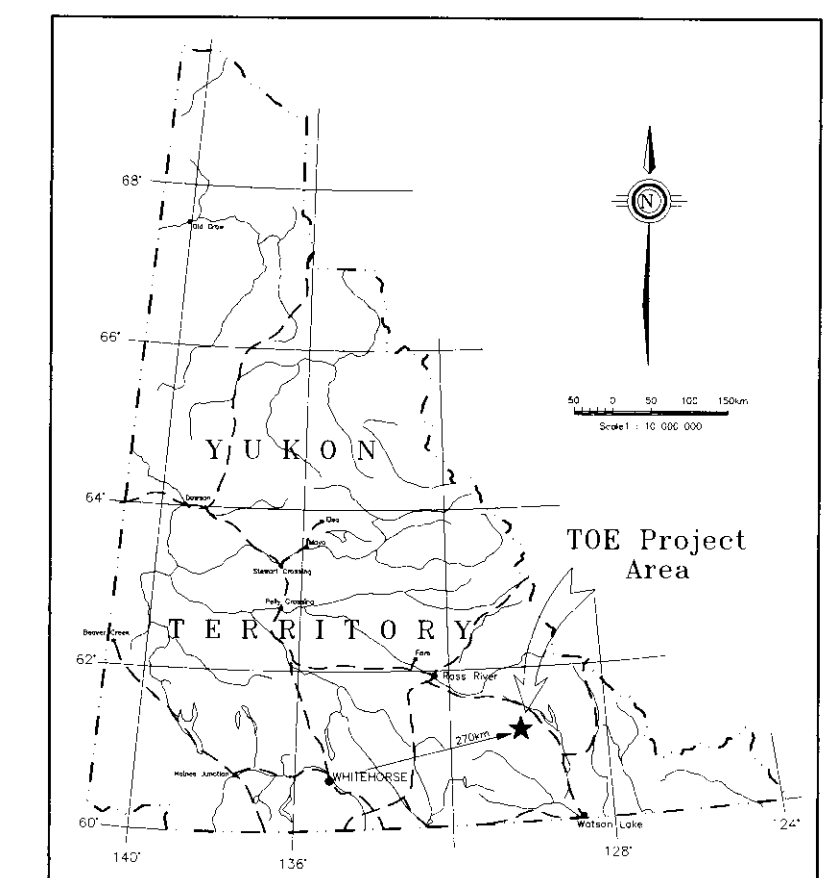
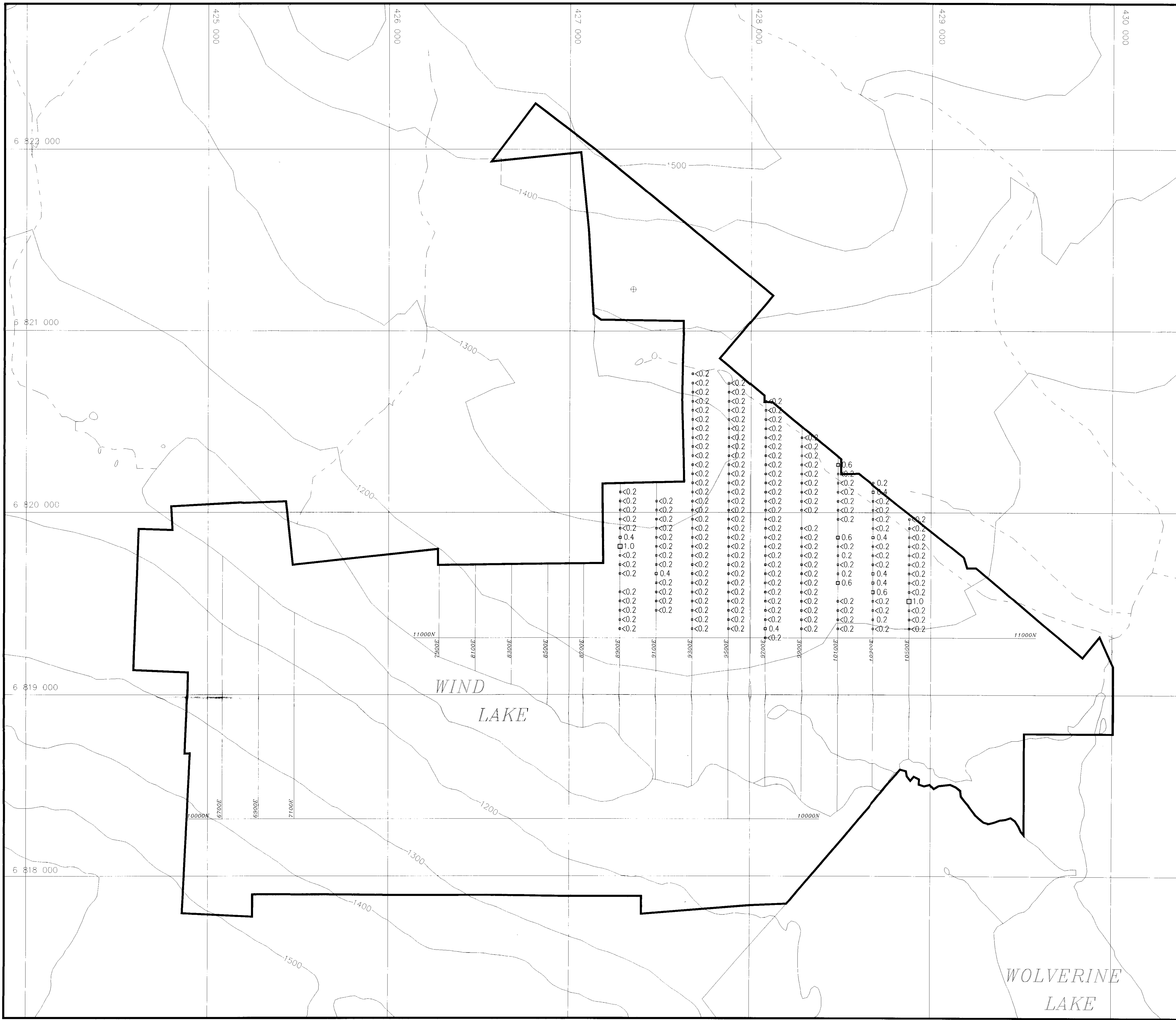

LOCATION MAP

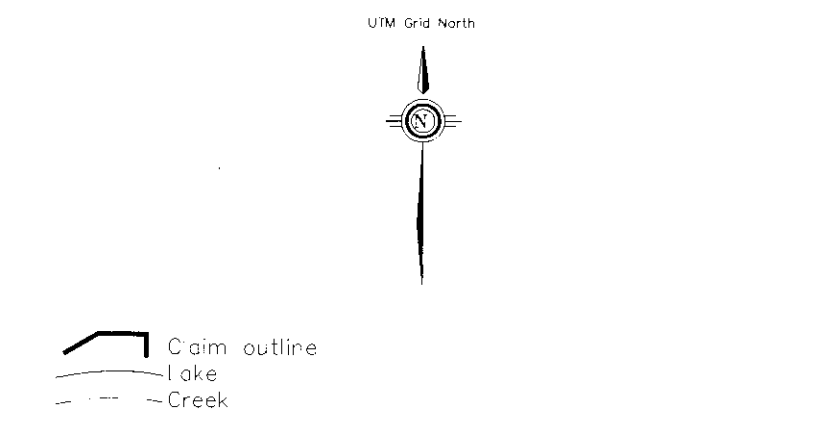

Ag in Soil (in ppm)
 Max □ 1
 Min ○ 0.1

093782

DWG ②

	WESTMIN RESOURCES LIMITED ATNA RESOURCES LTD.	
	TOE Property	
Work By WESTMIN Date Drafted Dec. 12, 1996 Drafted By A.T. & J.K. Date Revised	Ag in Soil (in ppm)	
Revised By	N.T.S. Number 105 G/8-9 File Name TOE_C_97.DWG	
	Figure	6.2

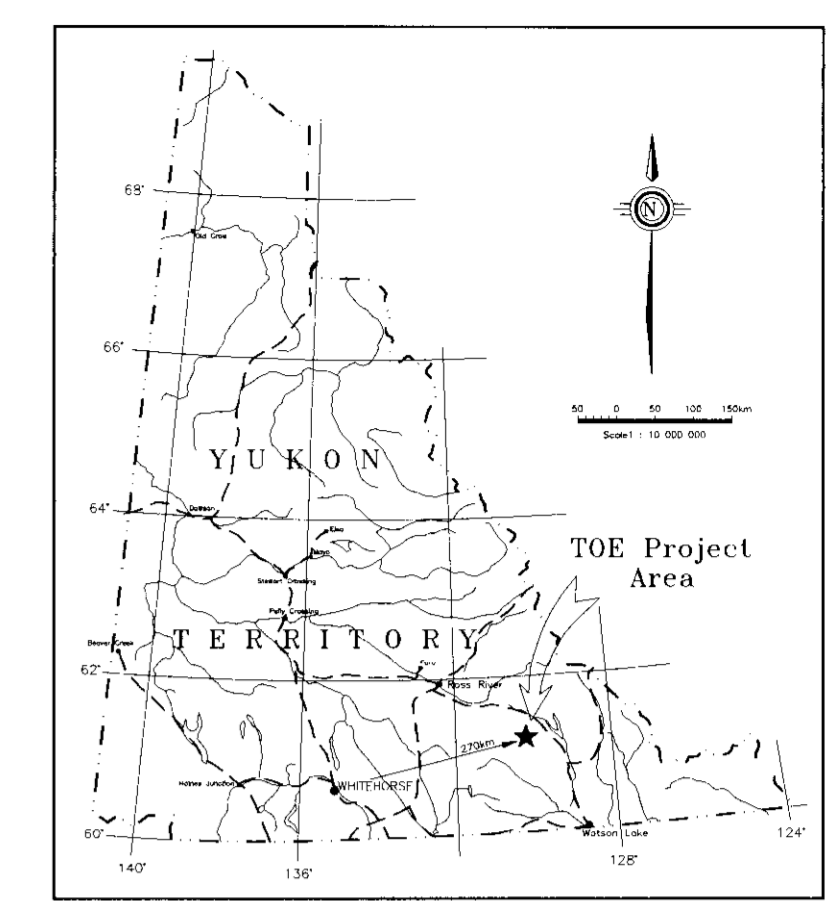
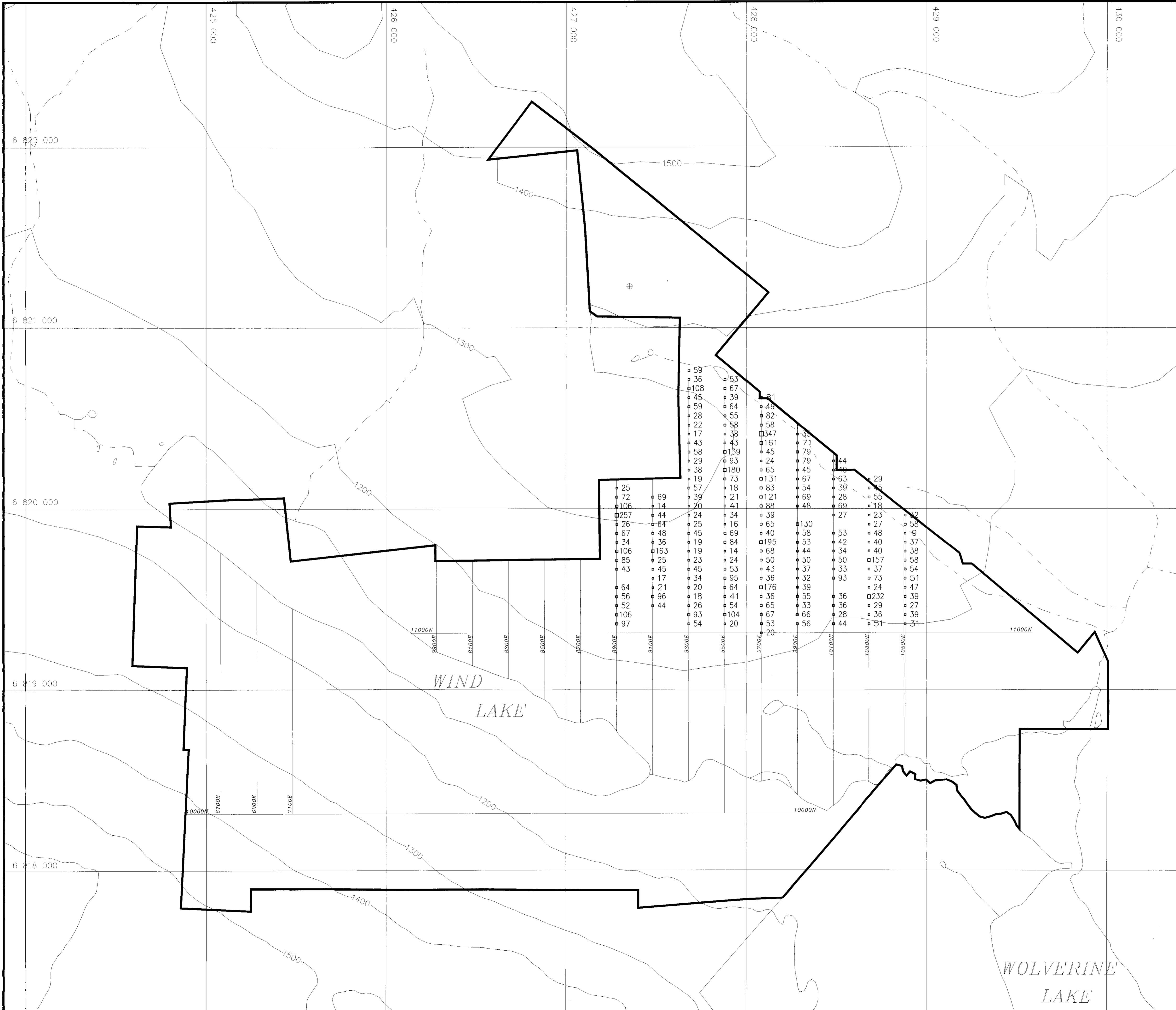

LOCATION MAP

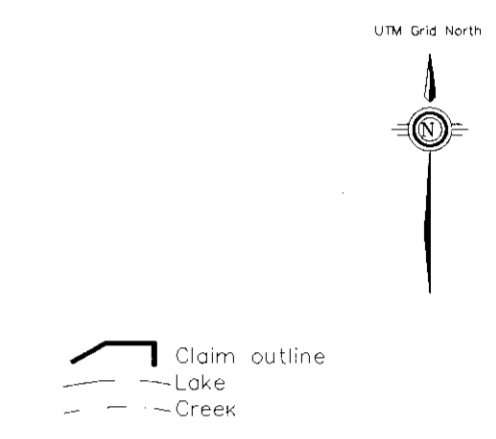

Cu in Soil (in ppm)
 Max □ 347
 Min • 9

093782

Dwg 3

WESTMIN RESOURCES LIMITED ATNA RESOURCES LTD.	
TOE Property	
Cu in Soil (in ppm)	
Work By WESTMIN Date Drafted Dec. 12, 1996 Drafted By A.T. & J.K. Date Revised Revised By	N.T.S. Number 105 G/8-9 File Name TOE_C_97.DWG
	Figure 6.3

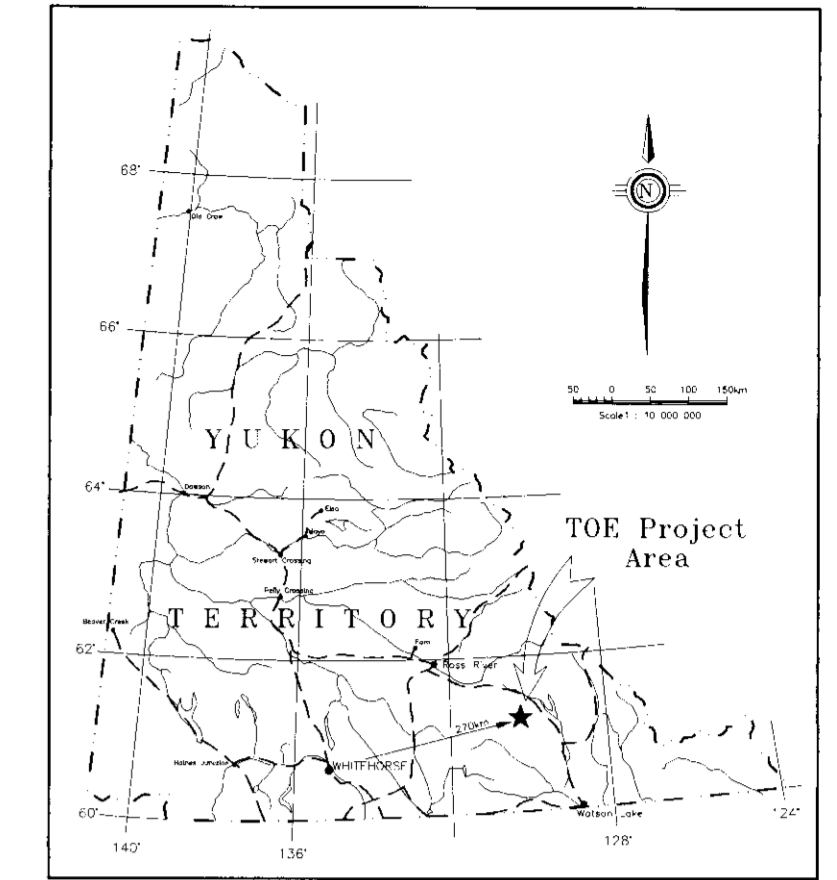
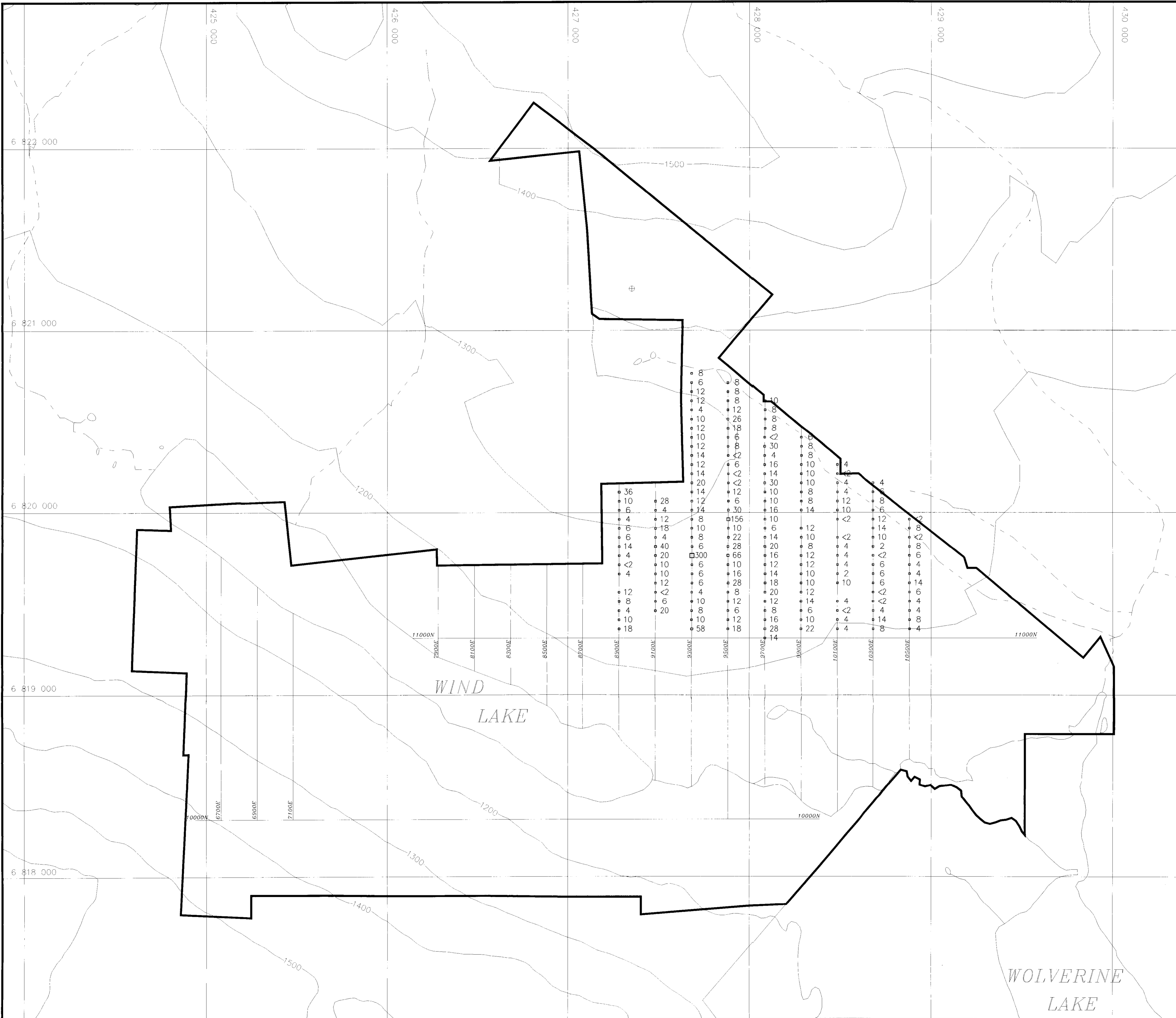

LOCATION MAP



Pb in Soil (in ppm)
 Max 300
 Min 1

093782

Dwg 4

WESTMIN WESTMIN RESOURCES LIMITED ATNA RESOURCES LTD.	
TOE Property	
Pb in Soil (in ppm)	
Work By WESTMIN	
Date Drafted Dec. 12, 1996	
Drafted By A.T. & J.K.	
Date Revised	
Revised By	Figure 6.4
N.T.S. Number 105 G/8-9	
File Name TOE_C_97.DWG	

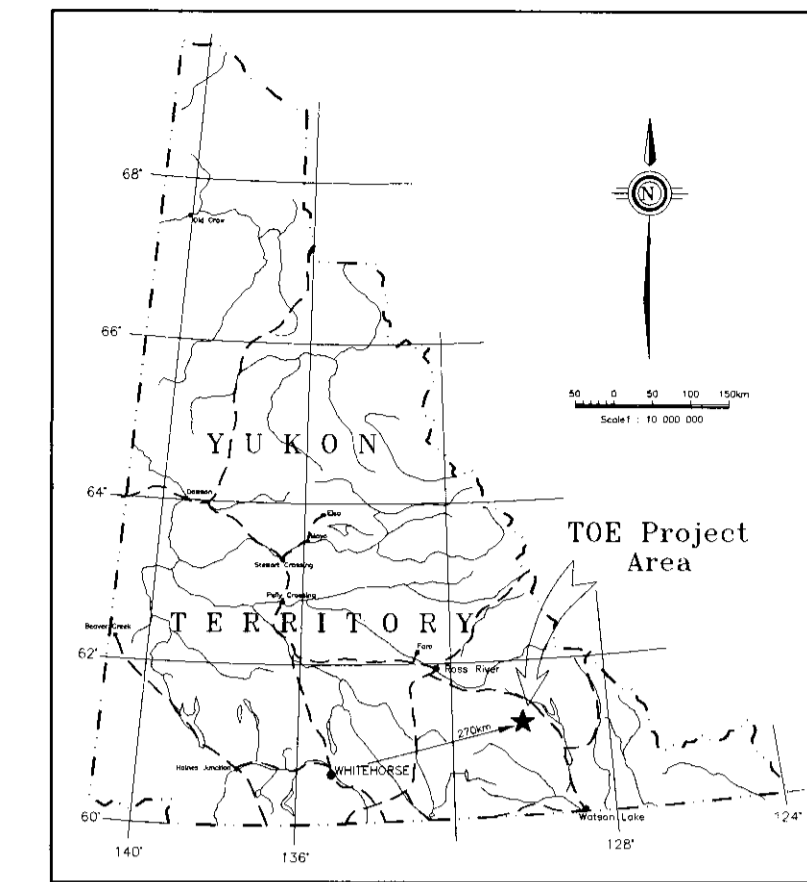
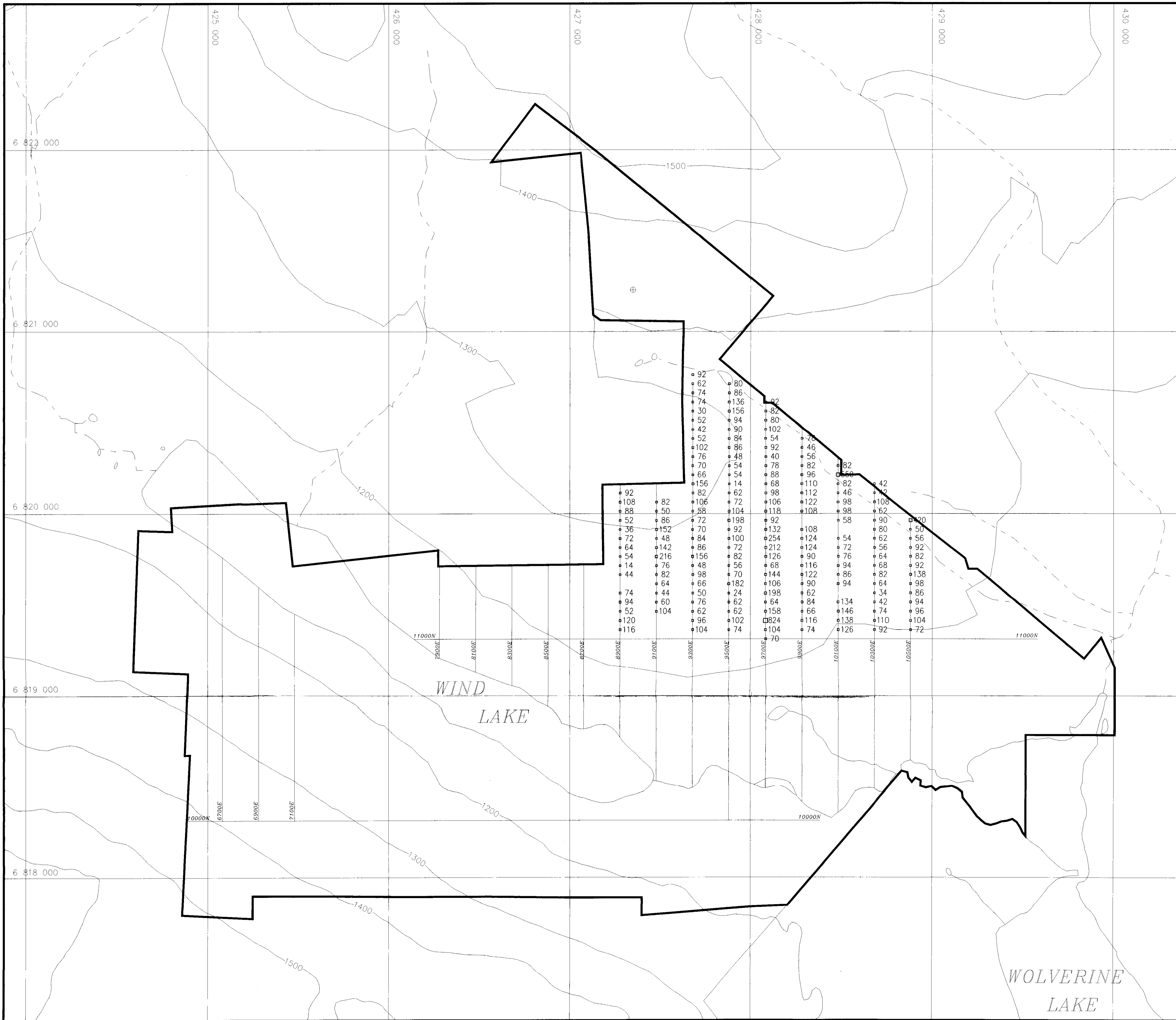

LOCATION MAP

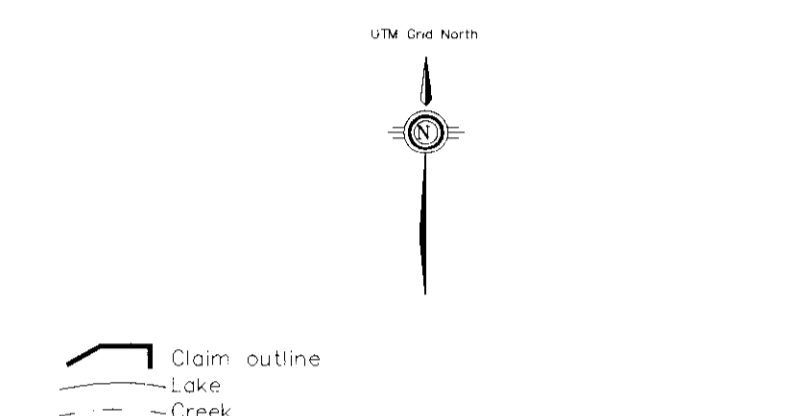

Zn in Soil (in ppm)
 Max 824
 Min 14

093782

Dwg 5

WESTMIN		WESTMIN RESOURCES LIMITED	
Work By WESTMIN		ATNA RESOURCES LTD.	
Date Drafted Dec. 12, 1996		TOE Property	
Drafted By A.T. & J.K.		Zn in Soil (in ppm)	
Date Revised			
Revised By			
N.T.S. Number 105 G/8-9		200 0 200 400 600m Figure	
File Name TOE_C_97.DWG		6.5	

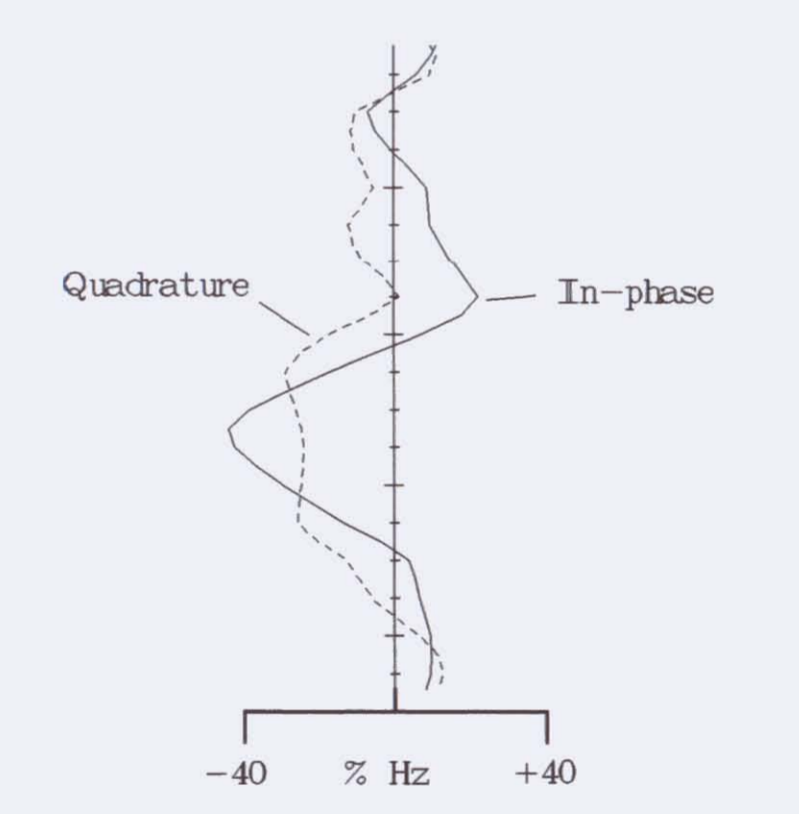
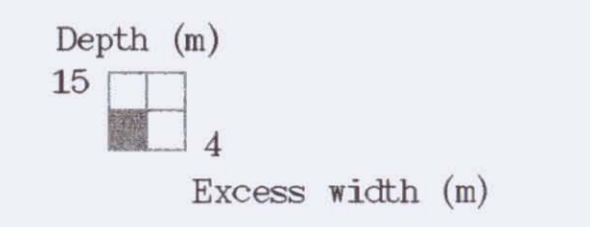
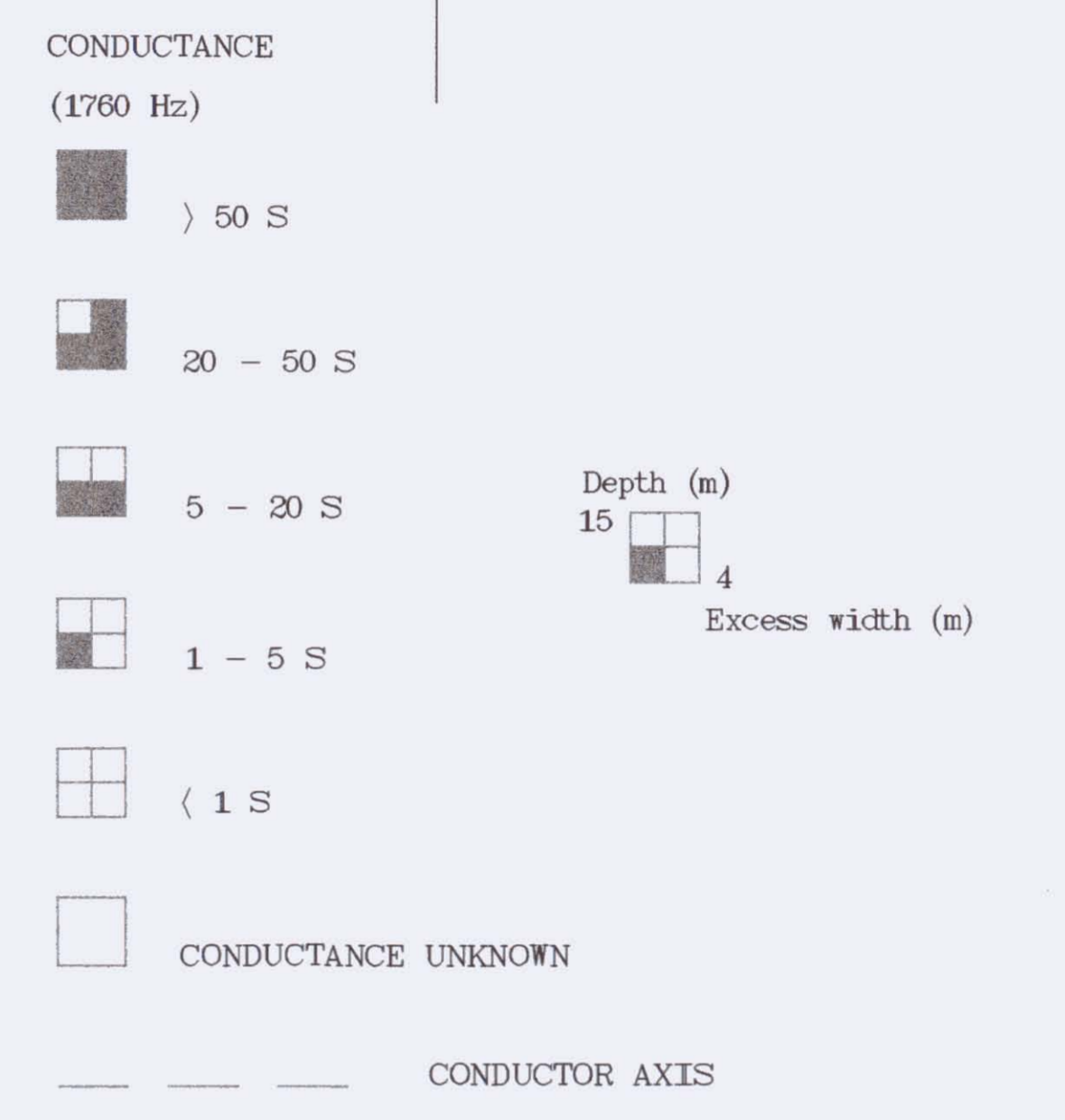
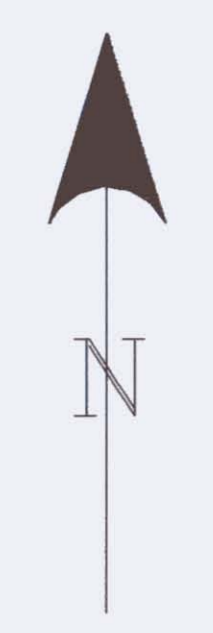

WESTMIN RESOURCES LIMITED

TOE PROPERTY
(NTS 105 G 8)
FIGURE TO-1

MAXMIN I-10 SURVEY
440 Hz - 100m coils

AMEROK GEOSCIENCES LTD.

098782

DWG 7

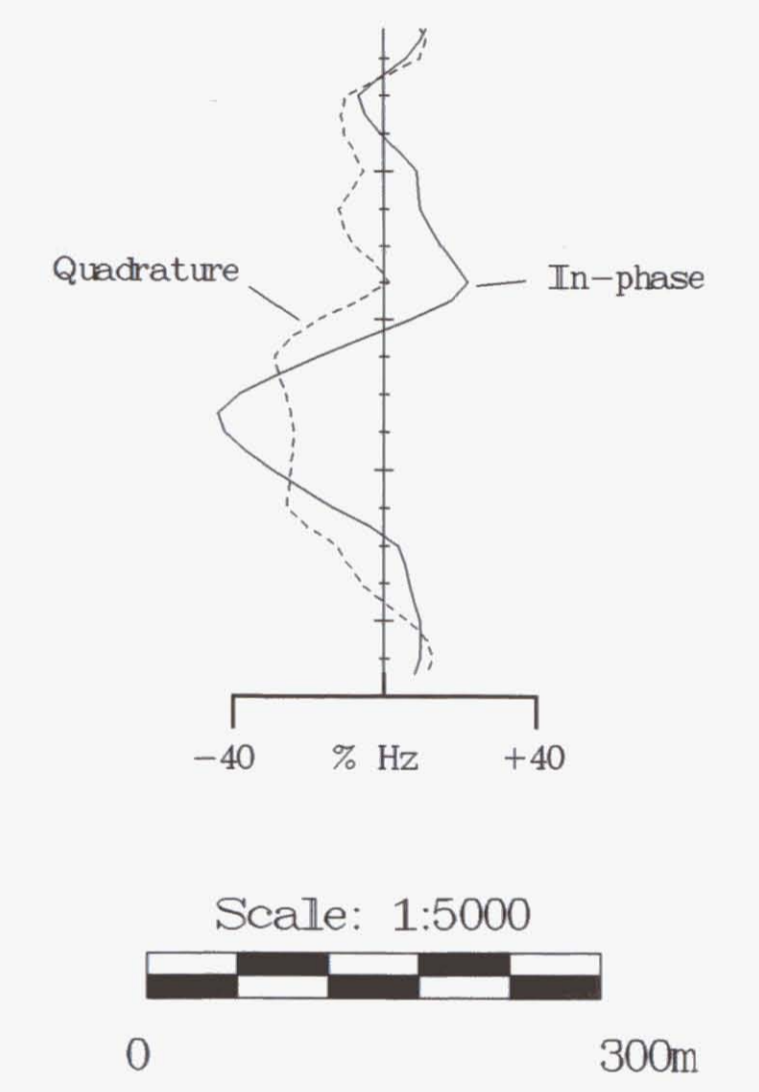
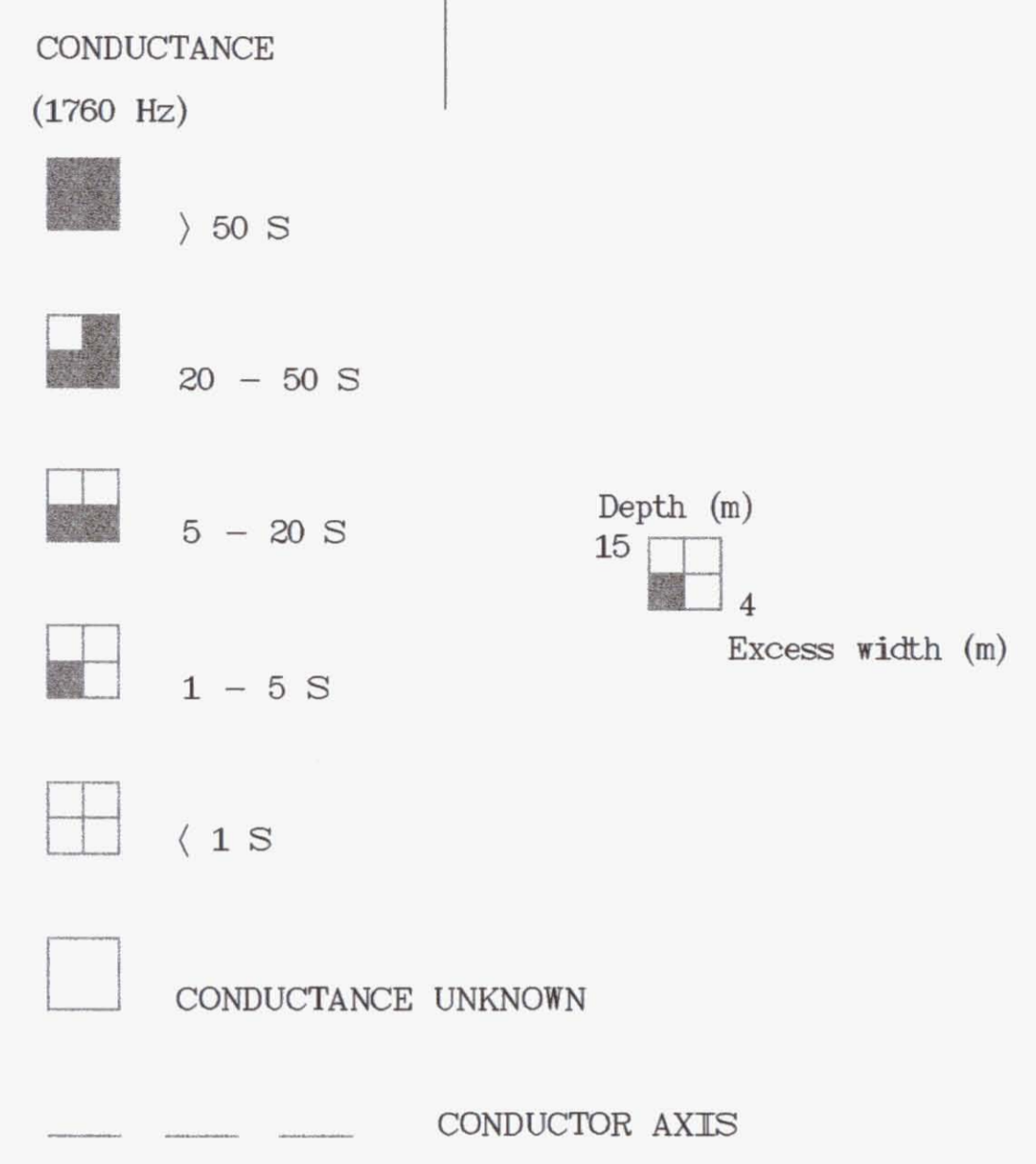
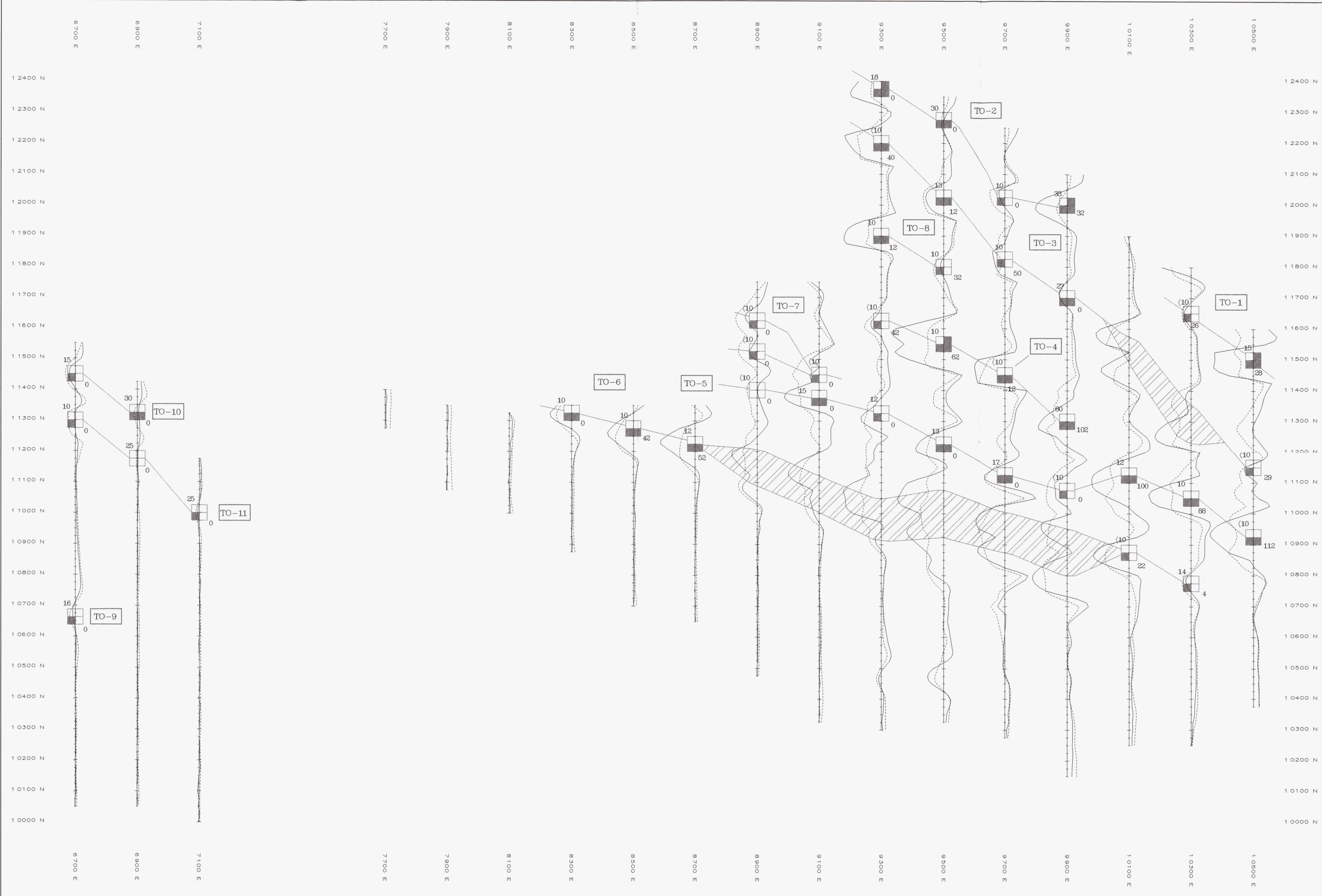

WESTMIN RESOURCES LIMITED

093782
TOE PROPERTY
(NTS 105 G 8)
FIGURE TO-2

MAXMIN I-10 SURVEY

880 Hz - 100m coils

AMEROK GEOSCIENCES LTD.

DWG 8

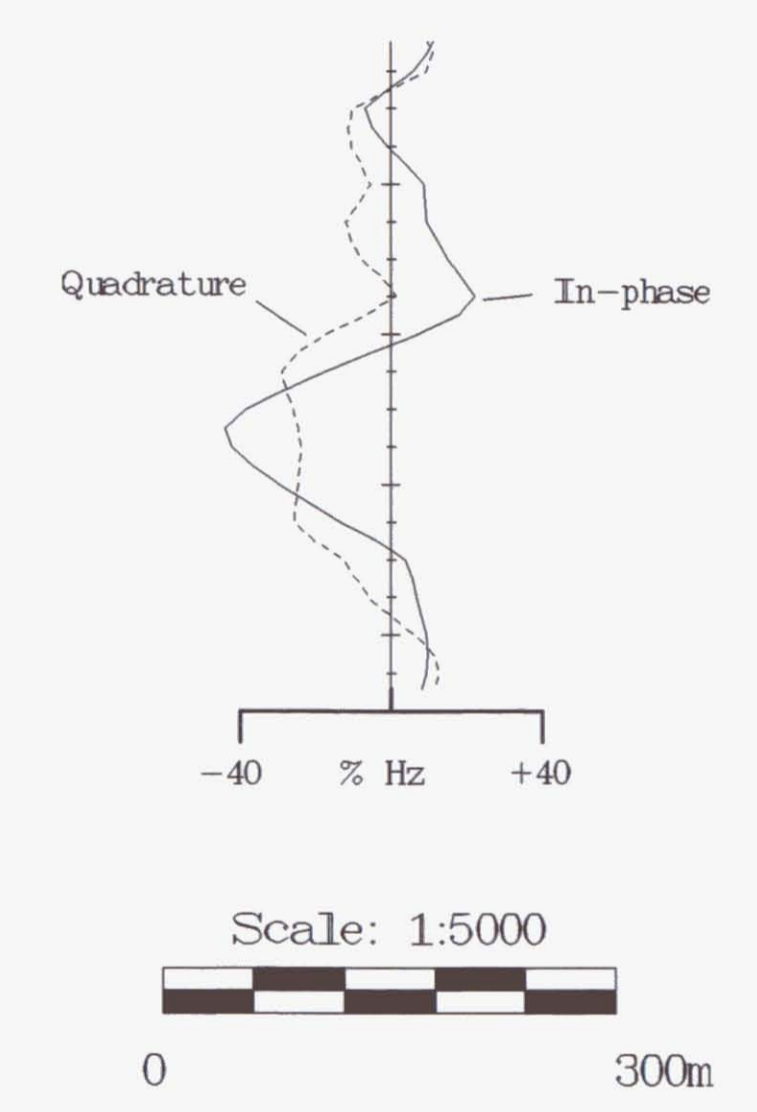
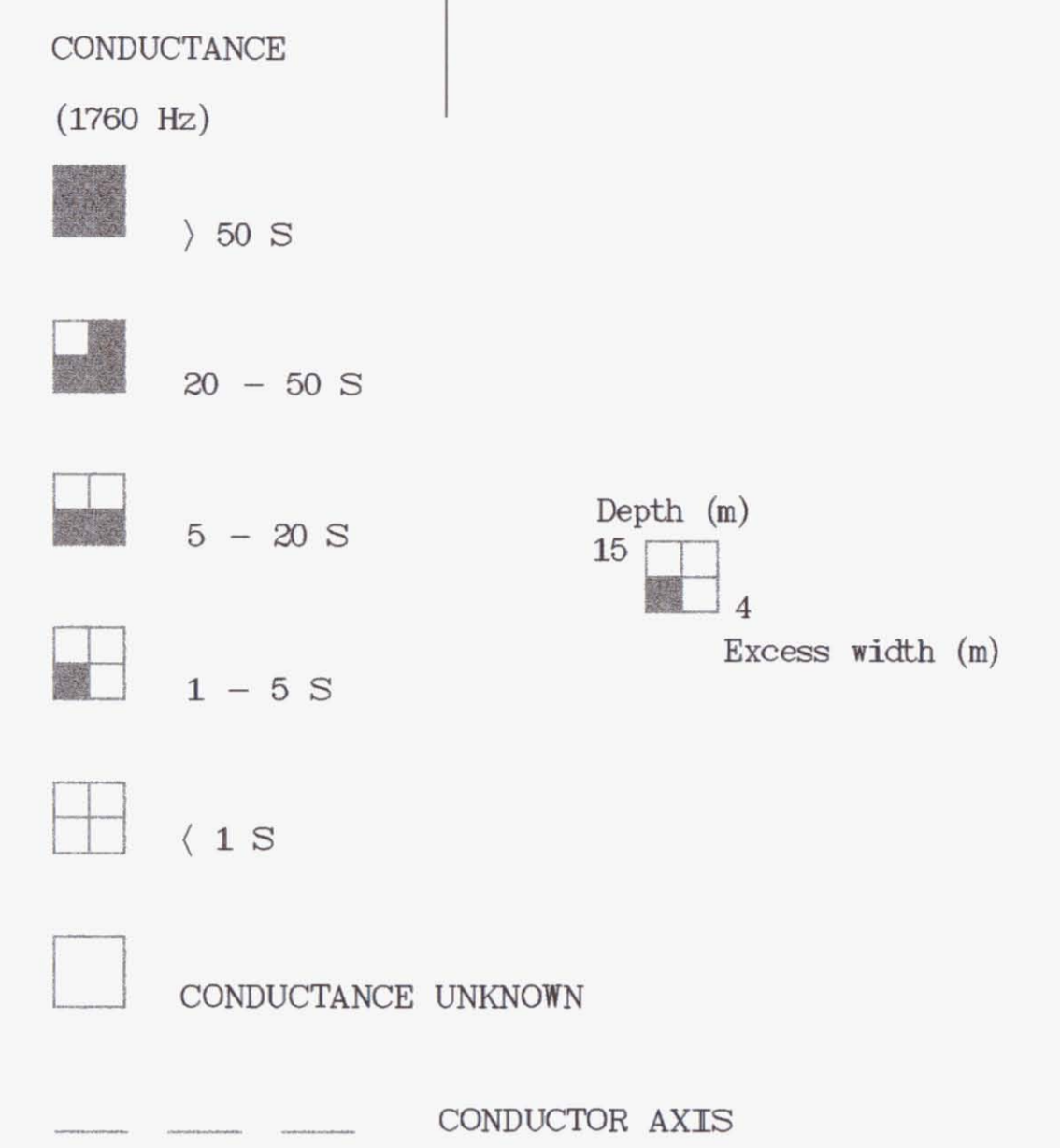
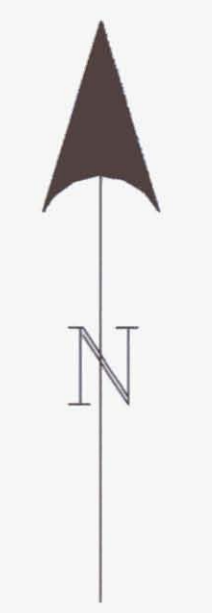
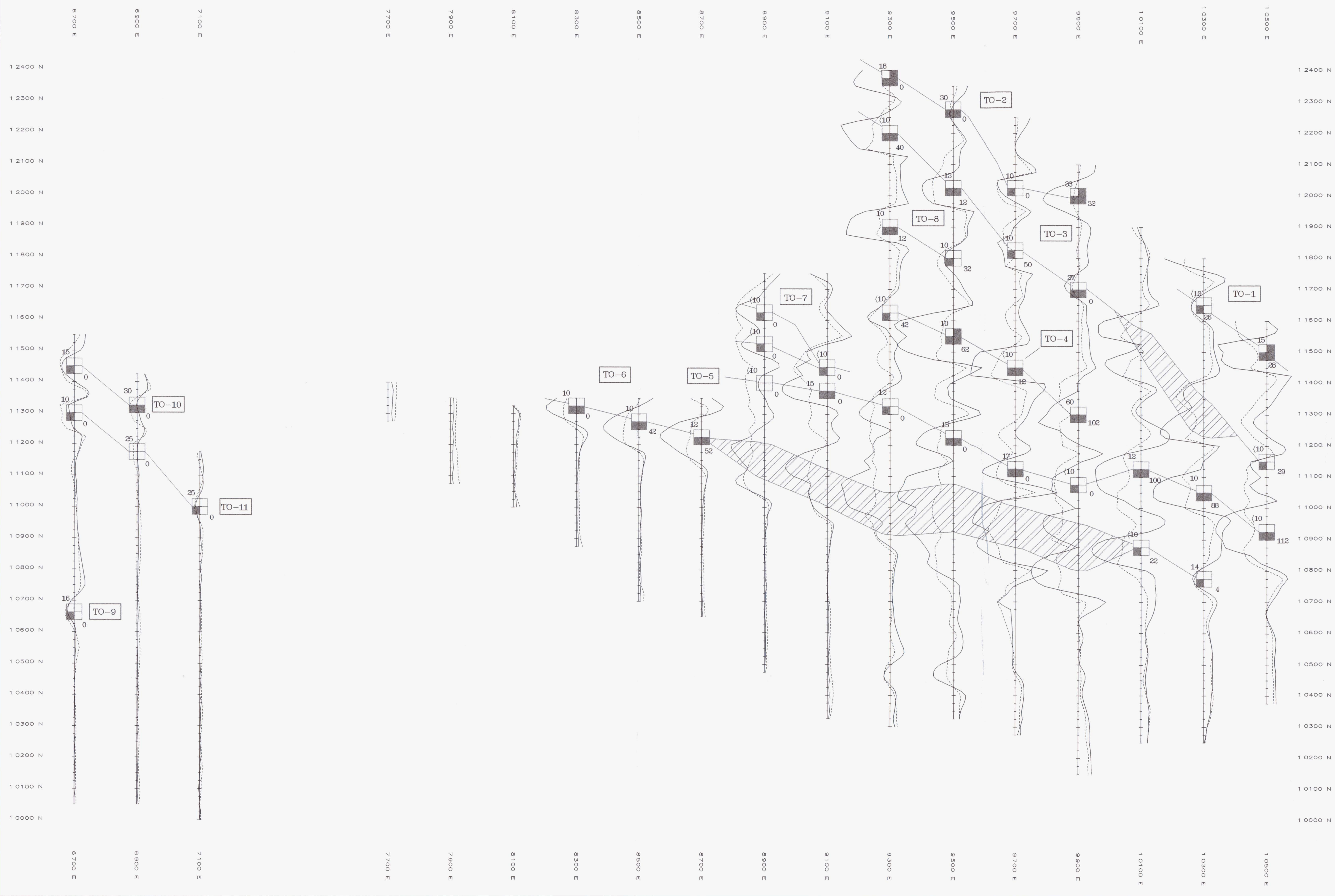

WESTMIN RESOURCES LIMITED

TOE PROPERTY
(NTS 105 G 8)
FIGURE TO-3

MAXMIN I-10 SURVEY

1760 Hz - 100m coils

DIAND - YUKON REGION, LIBRARY

AMEROK GEOSCIENCES LTD.

093782

DWG 9

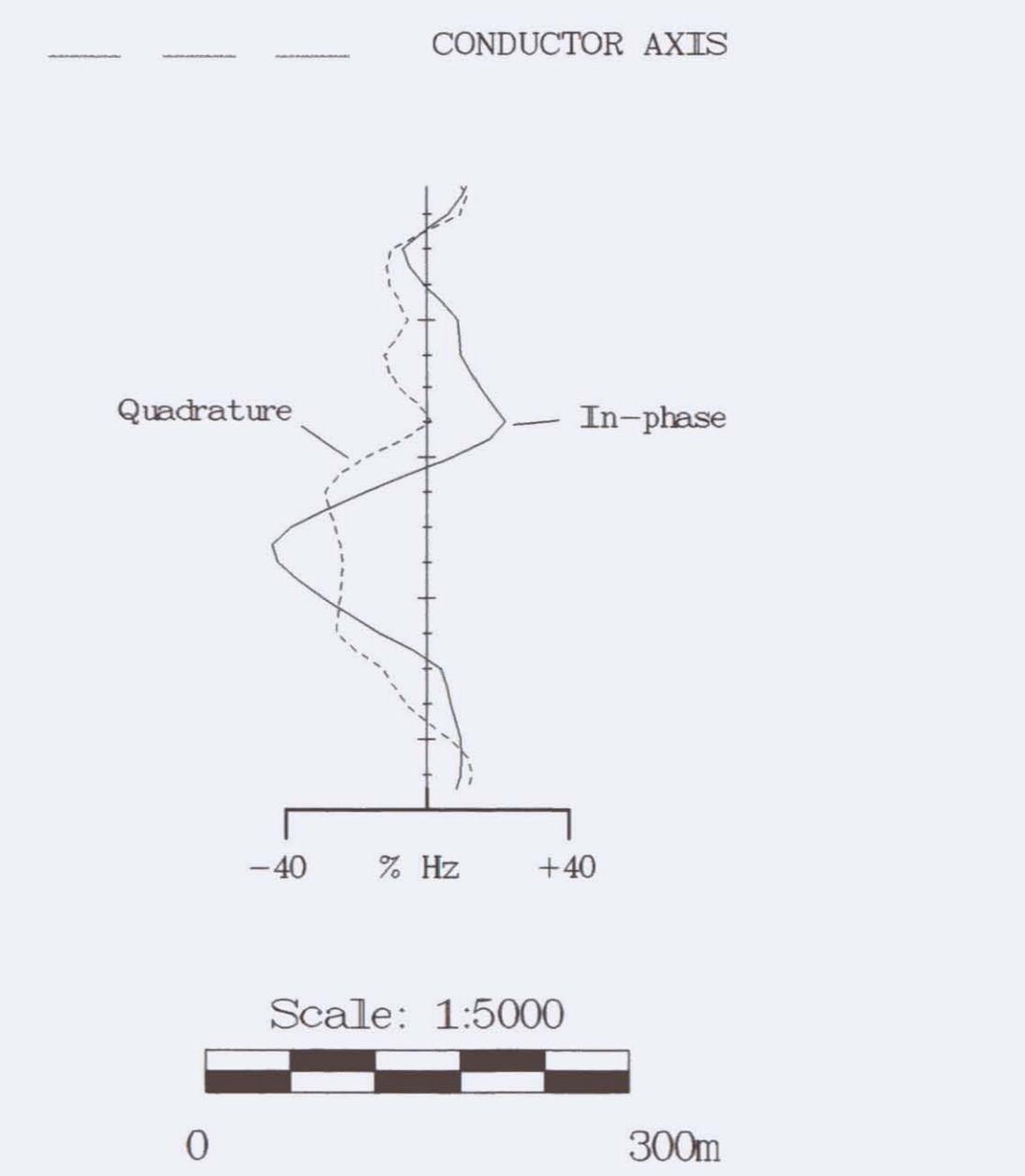
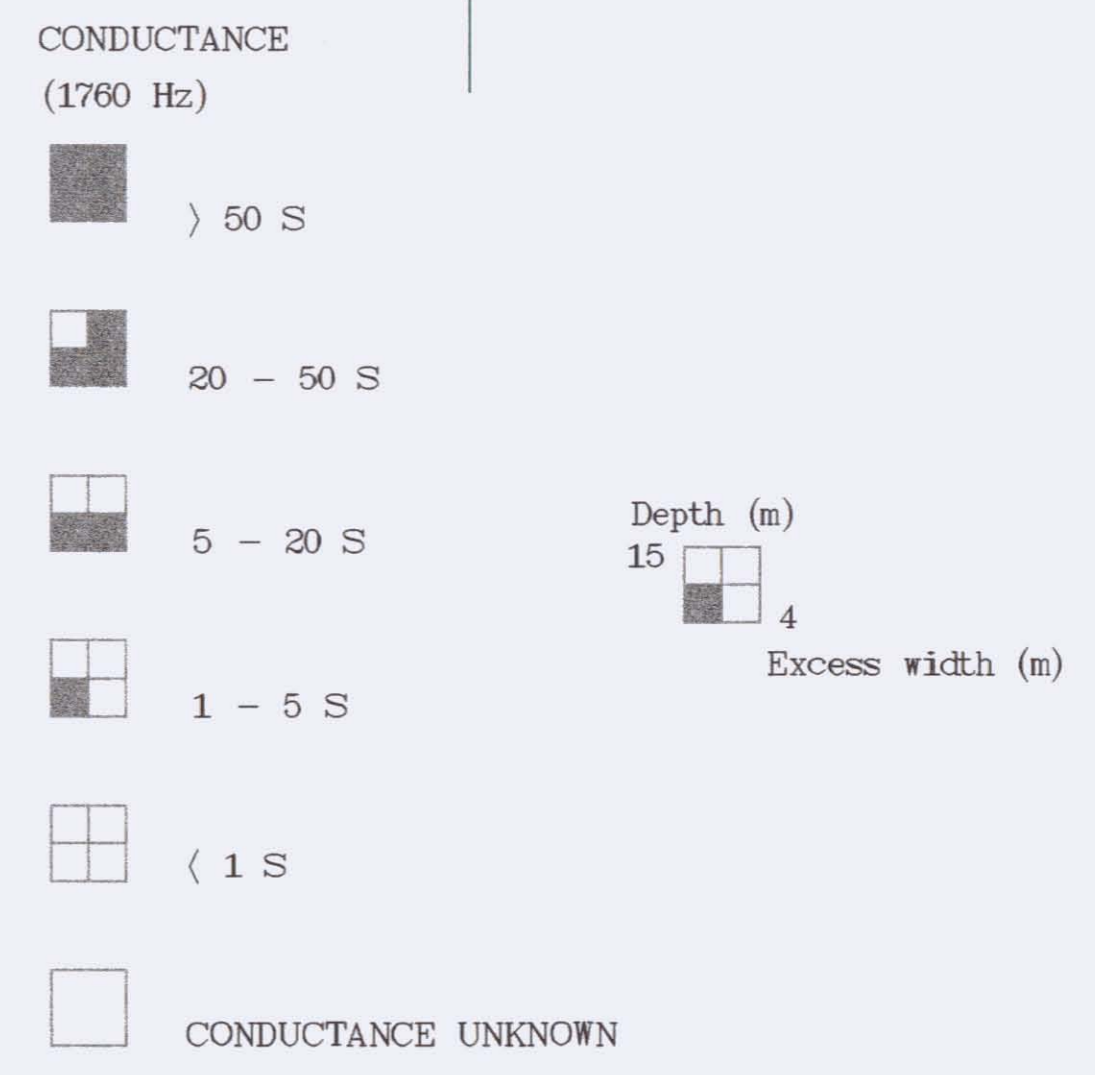
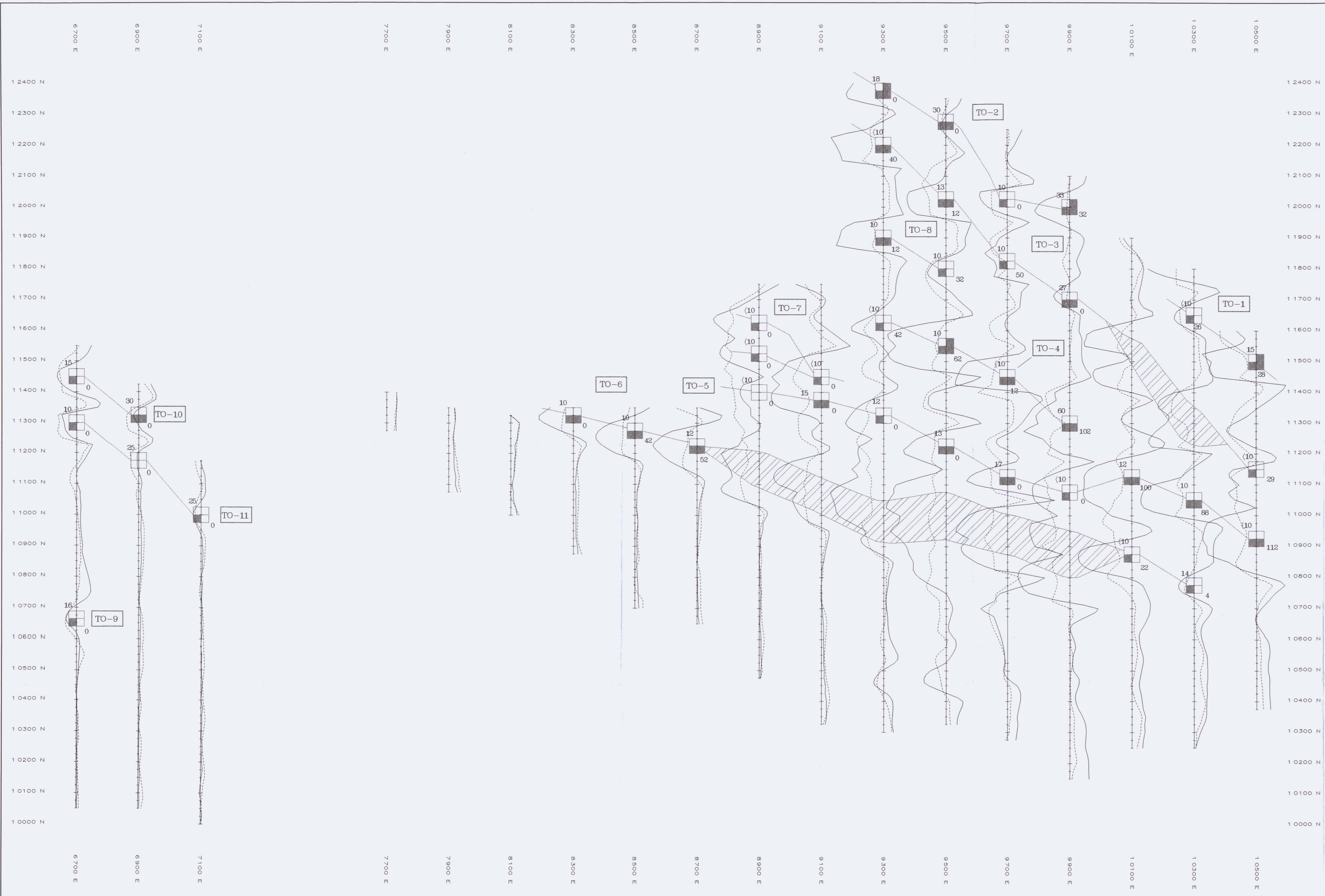

WESTMIN RESOURCES LIMITED

TOE PROPERTY
(NTS 105 G 8)
FIGURE TO-4

MAXMIN I-10 SURVEY
3520 Hz - 100m coils

AMEROK GEOSCIENCES LTD.

1093782

DWG
10

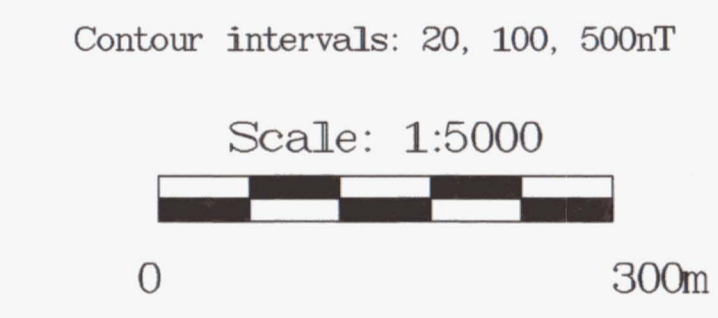
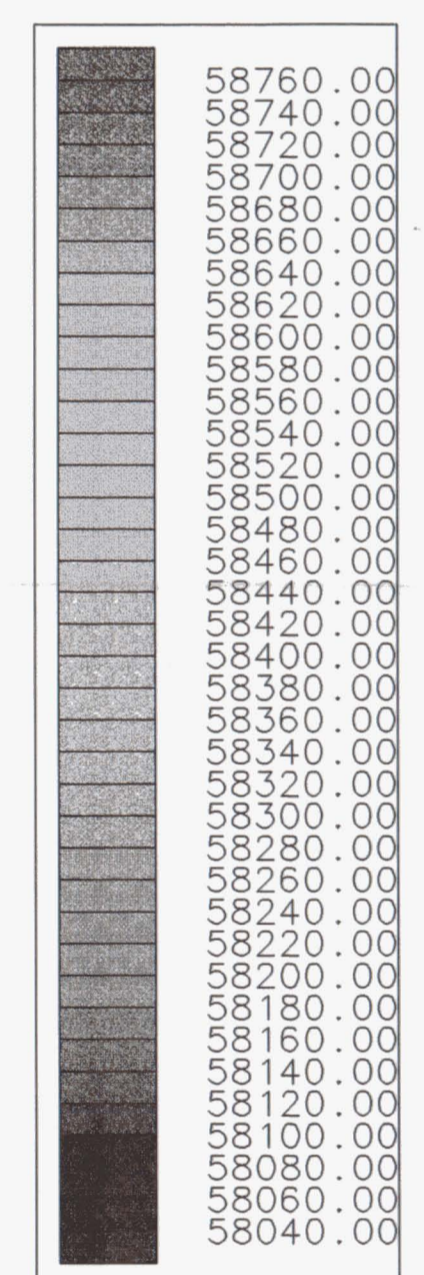
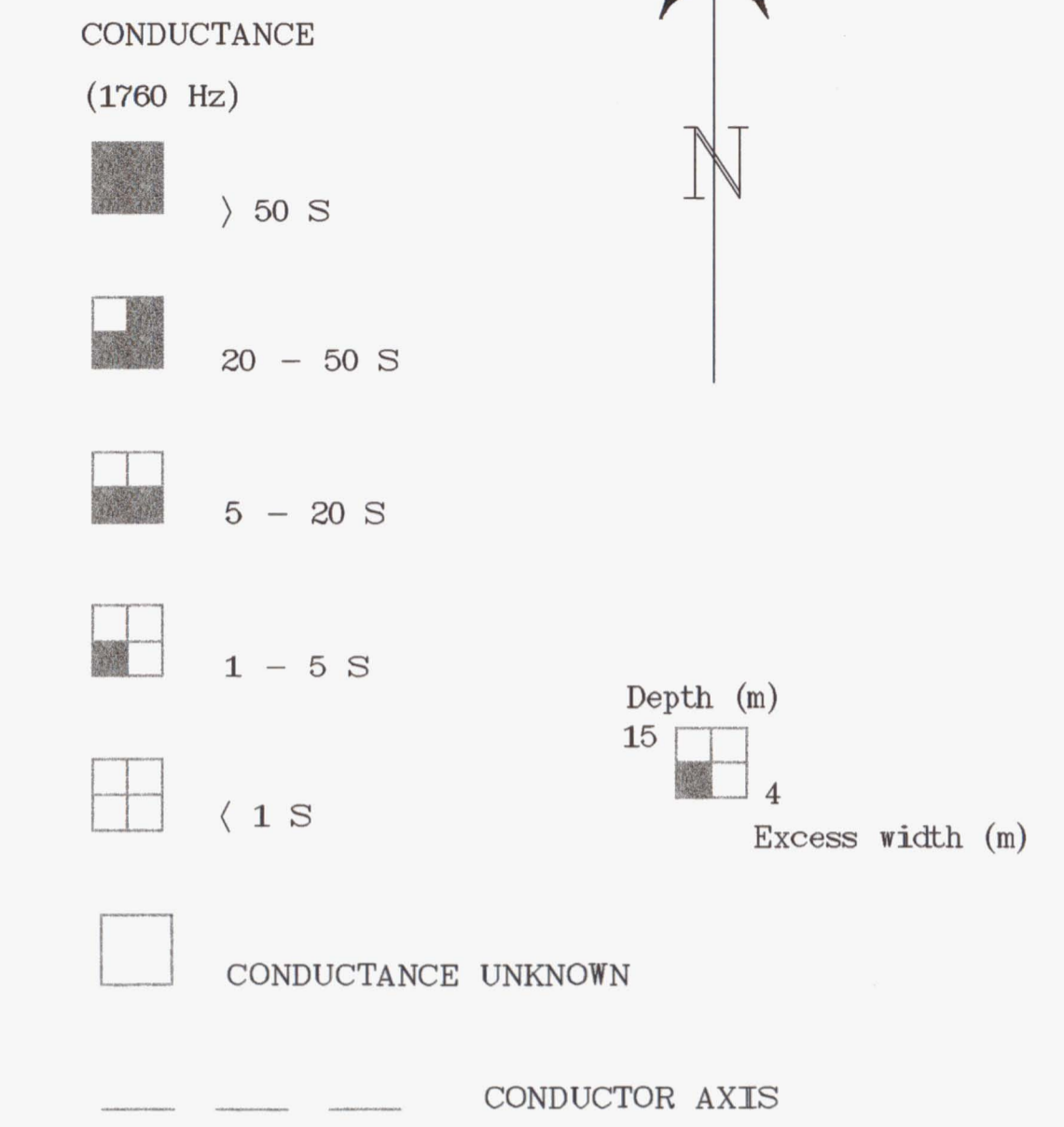
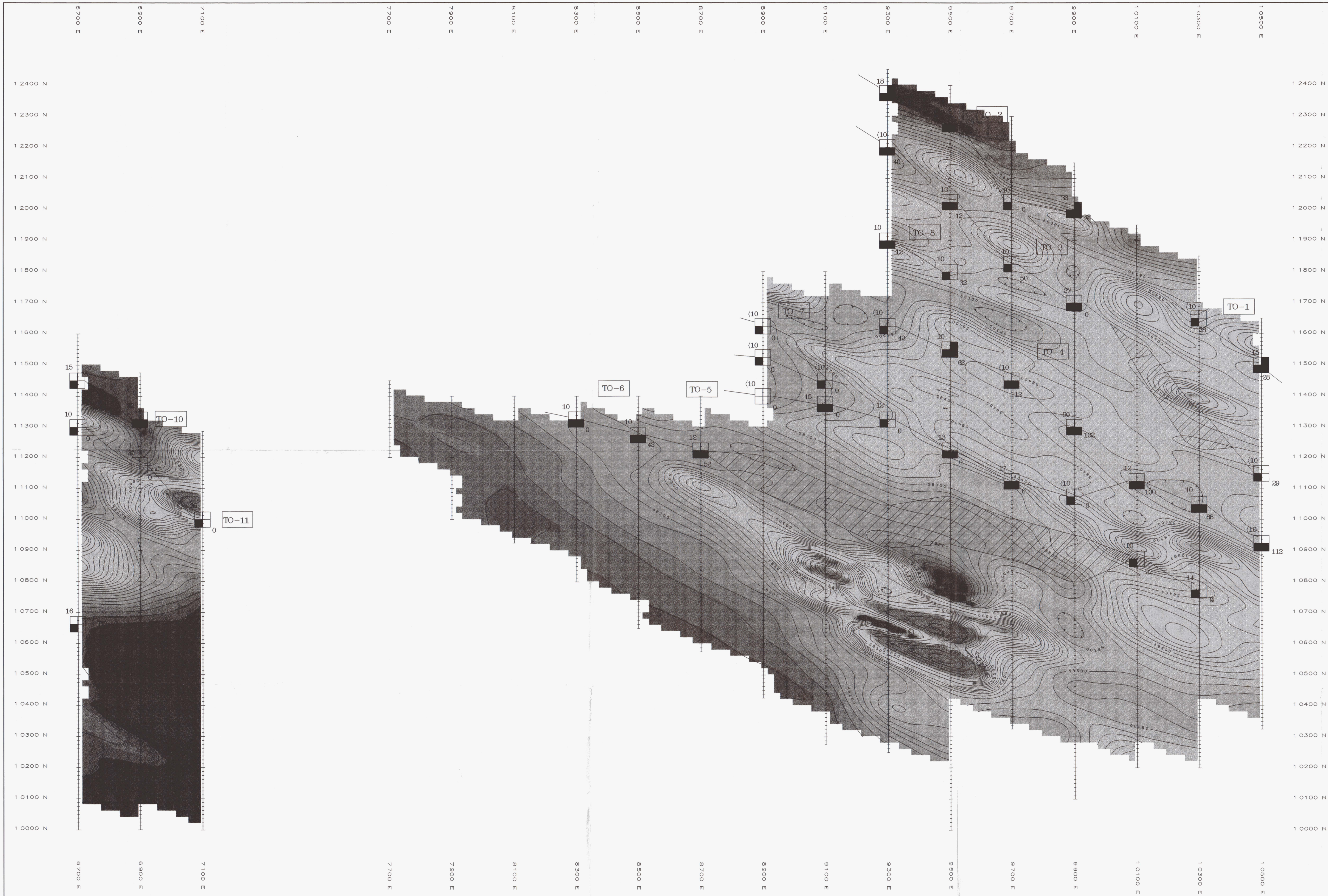

WESTMIN RESOURCES LIMITED

093782

TOE PROPERTY
(NTS 105 G 8)

FIGURE TO-5

TOTAL MAGNETIC FIELD SURVEY
CONTOUR MAP

AMEROK GEOSCIENCES LTD.