

REPORT ON THE
INDUCED POLARIZATION
AND
RESISTIVITY SURVEY
AND THE
TOTAL FIELD MAGNETIC SURVEY

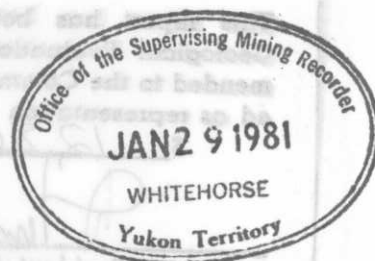

C A R I B O U C L A I M G R O U P

WATSON LAKE MINING DISTRICT
CARIBOU LAKE AREA, YUKON TERRITORY
N.T.S. 105B/7
60°23'N, 130°43'W

FOR

CORDILLERAN ENGINEERING



BY

Paul A. Cartwright, B.Sc., Geophysicist
and

Philip G. Hallof, Ph.D., P.Eng., Geophysicist

PHOENIX GEOPHYSICS LIMITED
214 - 744 West Hastings Street
Vancouver, B.C. V6C 1A6

JANUARY, 1981

CLAIMS: Caribou Mineral Claims, Numbers 1 to 32 inclusive
LOCATION: 109 km (68 mi) northwest of Watson Lake, Y.T.
DATE: July 11 to July 29, 1980.

090716

This report has been examined by the Geological Evaluation Unit and is recommended to the Commissioner to be considered as representation work under Section 53 (4) Yukon Quartz Mining Act.

12,800.00

[Signature]
 Resident Mining Engineer

[Signature]
 P. R. BAXTER
 Supervising Mining Recorder

[Signature]
 Commissioner of Yukon Territory



CORDILLERAN ENGINEERING

Paul A. Cartwright, B.Sc., Geophysicist
 and
 Philip G. Hallor, Ph.D., P.Eng., Geophysicist

PHOENIX GEOPHYSICS LIMITED
 214 - 744 West Hastings Street
 Vancouver, B.C. V6C 1A6

JANUARY, 1981

CLAIMS: Carbon Mineral Claims, Numbers 1 to 32 inclusive
 LOCATION: 10.7 km (6.8 mi) northwest of Watson Lake, Y.T.
 DATE: July 11 to July 29, 1980.

[Handwritten mark]

FROM Mining Recorder at Watson Lake

TO Supervising Mining Recorder at Whitehorse, Y.T.

FOR ACTION ARE

NEW APPL'N for PLACER LEASE to PROSPECT: Name _____ Lease No. _____

RENEWAL APPL'N PLACER LEASE to PROSPECT: Name _____ Lease No. _____

AFFIDAVIT of EXPENDITURE on PLACER LEASE. Name _____ Lease No. _____

ASSIGNMENT of PLACER LEASE No. _____
From: _____ To: _____

GROUPING APPL'N UNDER SEC. 52(2) PLACER MINING ACT.
Owner: _____

DIAMOND DRILL LOGS.
Claims: _____ Claim sheet no. _____

QUARTZ ASSESSMENT REPORT
Claims: CARIBOU 1-32 Claim sheet no. 105-B-7

Type of report:
Geophysical

Submitted by:
Cordilleran Engineering

Cls. work performed on:
CARIBOU 17-22
25-29

\$ Req. for ren. application
\$12,800.00

[Signature]
Signature

REPLY ACTION

Date Ret. _____

Signature _____

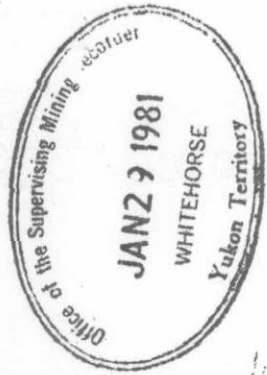



Department of Indian Affairs and Northern Development
YUKON QUARTZ MINING ACT

FORM "C" - APPLICATION FOR A CERTIFICATE OF WORK

(This form required in duplicate with sketch showing location of work.)



I (Name) CARL G. VERLEY Occupation GEOLOGIST
 (Postal Address) 1418-355 BURKARD STREET, VANCOUVER, B.C.

OFFICE DATE STAMP

GROUP 1

MAKE OATH AND SAY, THAT :-

- I am the ~~owner~~ agent of the owner, of the mineral claim(s) to which reference is made herein.
- I have done, or caused to be done, work on the following mineral claim(s):
 (Here list claims on which work was actually done by number and name)
YA 54205 to YA 54210 CARIBOU 3 to 8
YA 54213 to YA 54218 CARIBOU 11 to 16

SHOW DATES WORK COMMENCED AND ENDED ON CLAIMS HAVING DIFFERENT ANNIVERSARY DATES

situated at CARIBOU LAKE Claim Sheet No. 105817
 in the WATSON LAKE Mining District, to the value of at least \$6400.00
 dollars, since the 31 day of MARCH 1980,
 to represent the following mineral claims under the authority of Grouping Certificate No. 2745
 (Here list claims to be renewed by number and name in numerical order)

YA 54203 - YA 54218 CARIBOU 1 to 16 - 4 YEARS - 64 CLAIM YEARS

- The following is a detailed statement of such work: (Set out full particulars of the work done in the twelve months in which such work is required to be done, as shown by Section 53.)

GEOPHYSICAL SURVEYS WERE CONDUCTED DURING THE PERIOD JULY 11 to 29, 1980.
 A TOTAL OF 13.5 km OF SURVEYS WERE CONDUCTED ON THE PROPERTY AT A COST OF \$18,810.08 (\$1393.34/km) OF THIS 6.75 km WERE RUN ON GROUP 1. DETAILS OF THE WORK COMPLETED ARE CONTAINED IN THE REPORT ENTITLED "REPORT ON THE COMBINED GEOPHYSICAL SURVEYS ON THE CARIBOU CLAIM GROUP."

AMOUNT EXP'D GRP 1:
 $\$1393.34 \times 6.75 =$
 $\$9405.05$
\$2400.00 APPLIED
 EXCESS \$3005.05 NOT APPLIED.

Sworn before me at VANCOUVER B.C.
 this 28 day of November 1980

Anthony J. Jasich
 A Commissioner for Oaths for Yukon Territory.
 A Notary Public in and for the Province of British Columbia

Carl G. Verley
 Applicant.



CANADA) IN THE MATTER OF A GEOPHYSICAL REPORT
TO WIT :) ON BEHALF OF AMAX MINERALS EXPLORATION

I, CARL G. VERLEY, AGENT FOR CORDILLERAN ENGINEERING
OF 1418-355 BURRARD STREET, VANCOUVER, B.C. V6C 2G8

do solemnly declare, - THAT GEOPHYSICAL SURVEYS WERE
CONDUCTED ON THE CARBON #1-32 (INCLUSIVE) MINERAL
CLAIMS, WATSON LAKE MINING DISTRICT, Y.T. DURING THE
PERIOD JULY 11 TO 29, 1980. EXPENDITURES FOR
THIS WORK INCLUDE:

PROFESSIONAL SERVICES	\$ 4,500.00
SALARIES	2,678.00
MANAGEMENT FEES	2,678.00
GEOPHYSICAL SERVICES	7,942.50
FOOD	691.90
AIRCRAFT SUPPORT	319.68
		<u>\$ 18,810.08</u>

And I make this solemn declaration conscientiously believing it
to be true and knowing that it is of the same force and effect as if
made under oath and by virtue of the Canada Evidence Act.

Declared before me at VANCOUVER)
in the PROVINCE of B.C. this)
28 day of November, 1980)

Carl G. Verley

Christine J. Jansch
A notary Public in and for the
~~Yukon Territory~~ A Notary Public in and for the
Province of British Columbia



Department of Indian Affairs and Northern Development
YUKON QUARTZ MINING ACT

FORM "C" - APPLICATION FOR A CERTIFICATE OF WORK

(This form required in duplicate with sketch showing location of work.)



I (Name)	CARL G. VERLEY	Occupation	GEOLOGIST
(Postal Address)	1418 - 355 BURRARD STREET, VANCOUVER, B.C.		

OFFICE DATE STAMP

GROUP 2.

MAKE OATH AND SAY, THAT :-

1. I am the ~~owner~~ agent of the owner, of the mineral claim(s) to which reference is made herein.

2. I have done, or caused to be done, work on the following mineral claim(s):

(Here list claims on which work was actually done by number and name)

YA 54219 - YA 54224 CARIBOU 17 to 22
YA 54227 - YA 54231 CARIBOU 25 to 29

situated at CARIBOU LAKE Claim Sheet No. 105 B/7

in the WATSON LAKE Mining District, to the value of at least \$6400.00

dollars, since the 31 day of MARCH 19 80

to represent the following mineral claims under the authority of Grouping Certificate No. 2746

(Here list claims to be renewed in numerical order, by grant number and claim name, showing renewal period requested).

YA 54219 - YA 54234 CARIBOU 17 to 32 - 4 YEARS - 64 CLAIM YEARS

3. The following is a detailed statement of such work: (Set out full particulars of the work done indicating dates work commenced and ended in the twelve months in which such work is required to be done as shown by Section 53.)

GEOPHYSICAL SURVEYS WERE CONDUCTED DURING THE PERIOD JULY 11 TO 29, 1980. EXPENDITURES FOR A TOTAL OF 13.5 km OF SURVEYS WERE CONDUCTED ON THE PROPERTY AT A COST OF \$18,810.08 (\$1393.34/km) OF THIS 6.75 km WERE RUN ON GROUP 2. DETAILS OF THE WORK COMPLETED ARE CONTAINED IN THE REPORT ENTITLED "REPORT ON THE COMBINED GEOPHYSICAL SURVEYS ON THE CARIBOU CLAIM GROUP."

AMOUNT EXP'D
GRP 2
\$1393.34 x 6.75 =
\$9405.05
\$6400.00 APPLIED,
EXCESS \$3005.05
NOT APPLIED.

Sworn before me at VANCOUVER, B.C.
this 28 day of November 1980

Anthony J. Pasch
Notary Public A Notary Public in and for the Province of British Columbia

Carl G. Verley
Agent.

TABLE OF CONTENTS

<u>Part A:</u>	Report	12 pages	<u>Pages</u>
1.	Introduction		1
2.	Description Of The Claims		3
3.	Presentation of Results		3
4.	Discussion of Results		4
5.	Conclusions and Recommendations		6
6.	Assessment Details		8
7.	Statement of Cost		9
8.	Certificate - P.G. Hallof		10
9.	Certificate - P.A. Cartwright		11
10.	Certificate - J. Marsh		12
<u>Part B:</u>	Illustrations	14 pieces	
	Plan Maps (in pockets)	Dwg. I.P.P. 3088 Dwg. M.P. 3089	
	IP Data Plots	Dwg.No. 5245-1 to -12	

PHOENIX GEOPHYSICS LIMITED

REPORT ON THE
INDUCED POLARIZATION
AND RESISTIVITY SURVEY
AND THE TOTAL FIELD MAGNETIC SURVEY
ON THE
CARIBOU CLAIM GROUP
WATSON LAKE MINING DISTRICT
YUKON TERRITORY
FOR
CORDILLERAN ENGINEERING LTD.

1. INTRODUCTION

A program of Induced Polarization and Resistivity surveying and Total Field Magnetic surveying has been completed on the Caribou Claims grid on behalf of Cordilleran Engineering Ltd.

The Caribou property is located approximately 100 Km. west-north-west of Watson Lake, Yukon Territory on N.T.S. sheet 105 B-7. Access is via charter aircraft from Watson Lake.

The following description of the geology in the area of interest has been provided by the staff of Cordilleran Engineering Ltd. "Molybdenum mineralization occurs on the Caribou claim group in altered intrusives of

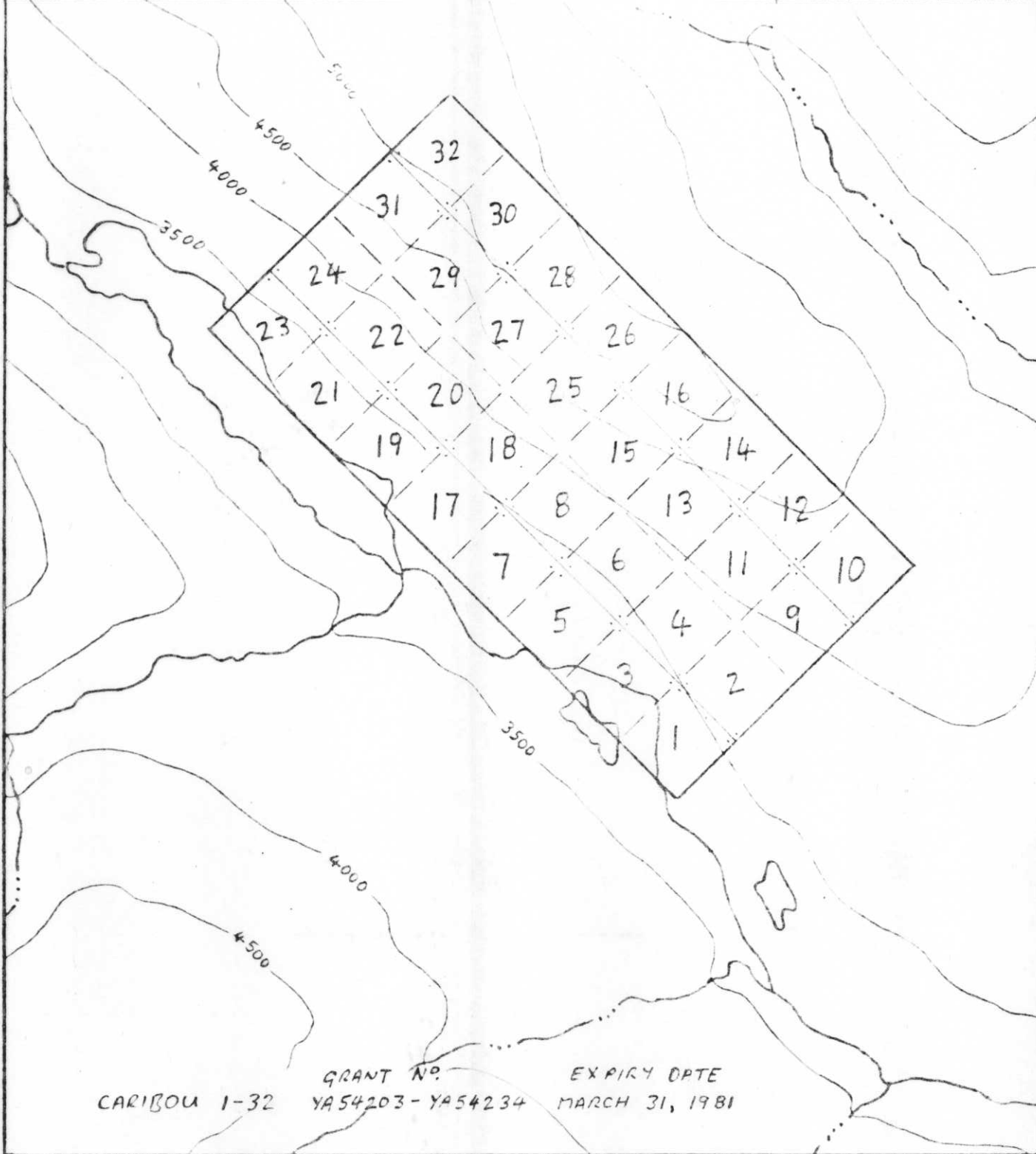

CARIBOU 1-32 GRANT NO. EXPIRY DATE
 YA54203 - YA54234 MARCH 31, 1981

CLAIM MAP CARIBOU GROUP

WATSON LAKE MINING DISTRICT, YUKON TERRITORY
 N.T.S. 105B-7

SCALE : 1 inch = 1/2 mile
 CONTOUR INTERVAL = 500 feet

presumably late Cretaceous age. At least two varieties of intrusive are present: a medium-grained quartz-feldspar porphyry (dominant type) and a finer-grained quartz-feldspar rock. Age relationships between the two rock types are not known. Alteration of both intrusives consists of a quartz-sericite-pyrite assemblage which grades laterally into a clay-bearing facies. Fracture controls for alteration are evident, but locally alteration is pervasive and intense.

Molybdenite is found in float between lines 3200W, 2400W and 600N to 900N. It occurs in quartz veins and disseminated in altered intrusive (predominantly clay facies). Disseminated pyrite is ubiquitous. Disseminated magnetite occurs in the most intensely altered sericite-quartz facies and in unaltered quartz feldspar porphyry.

The intrusives are hosted by Lower Cambrian or earlier (?) meta-sediments (grits and schists). The northern contact between intrusive and metasediments appears to lie between approximately 1200N and 1400N on the grid. East, west and southern contacts have not been located at present. Float of metasediment near the inferred intrusive contact is strongly altered and contains abundant disseminated pyrite.

Exposure on the claims is less than 1 percent."

It was hoped that the present IP and Resistivity survey, and the accompanying magnetic survey would delineate metallic sulphides and structures associated with molybdenum mineralization, as molybdenite is not directly detectable by any geophysical technique.

A Phoenix Model IPV-1, IPT-1 frequency domain IP system, operating at 5.0 Hz, and 0.31 Hz, was used to make the induced polarization and resistivity measurements, while a McPhar Model GP-70 proton magnetometer,

together with a McPhar Model M-700 base station recorder, were utilized for the magnetic readings.

All surveys were carried out under the supervision of Mr. John Marsh, Senior Crew Leader. His certificate of qualification is appended to this report.

Field work on the Caribou Claim Group was completed during July 1980.

2. DESCRIPTION OF THE CLAIMS

	<u>Grant No.</u>	<u>Expiry Date</u>
Caribou 1 - 32	YA 54203 - YA 54234	March 31, 1981

The reader is referred to Figure 1, a claim map of the property.

3. PRESENTATION OF RESULTS

The results of the geophysical surveys are shown on the following data plots. The induced polarization and resistivity data are plotted in pseudo-section form.

<u>Line</u>	<u>Electrode Interval</u>	<u>Dwg. No.</u>
3200W	100 meters	IP 5245-1
3000W	100 meters	IP 5245-2
2800W	100 meters	IP 5245-3
2600W	100 meters	IP 5245-4
2400W	100 meters	IP 5245-5
2200W	100 meters	IP 5245-6
2000W	100 meters	IP 5245-7
1800W	100 meters	IP 5245-8

<u>Line</u>	<u>Electrode Interval</u>	<u>Dwg. No.</u>
1600W	100 meters	IP 5245-9
1400W	100 meters	IP 5245-10
1200W	100 meters	IP 5245-11
1000W	100 meters	IP 5245-12

Also included with this report is Dwg. I.P.P. 3088, a plan map of the Caribou Claims grid. The definite, probable and possible IP and Resistivity anomalies are indicated by bars, in the manner shown on the legend, on this plan map as well as on the data plots.

The magnetic data is plotted in the form of a contoured plan map designated as Dwg. M.P. 3089.

The grid and topographic information shown on these plan maps has been taken from maps made available by the staff of Cordilleran Engineering Ltd.

4. DISCUSSION OF RESULTS

The most prominent feature seen in the contoured magnetic data is a region of lower than background magnetic susceptibility, roughly oval in shape, centered in the western corner of the grid area. One possible explanation for the low magnetic values would be the presence of a less magnetic rock unit such as the finer grained quartz feldspar intrusives. Higher than background magnetic readings are interpreted to form a concentric ring which encloses the magnetic low.

The regional trend of the magnetics shows decreasing values towards the southeast.

Induced Polarization and Resistivity surveying indicate that much

of the grid area around the magnetic low is underlain by very polarizable and quite conductive material. Geological mapping has noted the presence of metasediments, which undoubtedly are the primary source of the anomalous IP effects. However, in some instances, anomalous IP effects are seen extending into the region of low magnetic values, where intrusive rock may be present. These more interesting areas are discussed in relation to the three major zones of anomalous IP response outlined.

IP ZONE A

IP Zone A can be seen extending across all of the grid lines, just north of, and parallel to the baseline. For the most part, the trend consists of very anomalous polarizability measurements accompanied by very low apparent resistivity values, except for the southeastern end where higher resistivity values are noted. At the northwestern end of the zone on Line 2600W, the very anomalous core of the zone is indicated to be in the order of 500 meters wide, with less conductive, but highly polarizable material being present on either margin.

While metasedimentary material probably is responsible for most of the anomalous values recorded in IP Zone A, an interesting signature is evident in the data along the southern edge of the zone on Line 2600W through to Line 2000W. Here, very anomalous polarization effects accompanied by only moderate magnitude resistivity reading are indicated extending southwest of the possible metasediment-intrusive contact, as marked by magnetics. The presence of substantial amounts of disseminated metallic sulphides along the north-eastern margin of the less magnetic rock unit is quite probable.

ZONE B1 - ZONE B2

These features may in fact be part of one continuous zone, striking across the southwestern end of the grid lines, along the southwestern side of the magnetic low.

Generally, the individual responses detected in these zones are not as anomalous as is the case in Zone A, with the principal difference being the presence of higher apparent resistivity values in Zone B1, B2. This suggests that the sources are more disseminated in nature, possibly being very similar to the material detected along the southwest margin of Zone A.

The most encouraging responses from Zone B1, and B2 are those which are plotted within the region of the magnetic low, in that these particular anomalies are most probably not caused by the metasediments, but rather metallic sulphides within the intrusive rock.

5. CONCLUSIONS AND RECOMMENDATIONS

A distinct, roughly circular region of low magnetic values is indicated, by the contoured magnetic data, to be present in the western corner of the grid area. A concentric halo of higher than background values is also evident, surrounding the magnetic low. It is quite probable that these features outline the finer-grained quartz feldspar rock type, which, according to the geological description, does not host appreciable amounts of magnetite.

One very anomalous IP zone (Zone A) has been outlined in the data, however, metasedimentary material is probably the primary source material, with one exception. Anomalous results appear to extend southwest into the

region of the intrusive as mapped by the magnetics, in the vicinity of Line 2600W through to the area of Line 2000W. Further work should be concentrated in this region. An inclined diamond drill hole spotted so as to pass through a point approximately 100 meters below Station 8+50N, Line 2200W is recommended to test the margin of IP Zone A.

The source of IP Zone B1, and IP Zone B2 is indicated to be quite similar to the material causing the response along the southwestern margin of IP Zone A. Further work should therefore be deferred pending results of drilling on Zone A.

PHOENIX GEOPHYSICS LIMITED

Paul A. Cartwright

Paul A. Cartwright, B.Sc.
Geophysicist

Philip G. Hallof

Philip G. Hallof, Ph.D., P.Eng.
Geophysicist



Expiry Date: February 25, 1981

Dated: January 9, 1981

STATEMENT OF COST

Cordilleran Engineering Limited,
Caribou Claims - Contract No. PV1049
Watson Lake M.D., Y.T.

CREW: J. Marsh - G. Ouellette

PERIOD: July 14 - July 29, 1980

13.5	Line KM - IP Survey	@ \$385.00/KM	\$5,197.50
1	Day Detail IP	@ \$540.00/day	540.00
4	Days Standby	@ \$205.00/day	820.00
13.85	Line KM - Mag Survey	@ \$100.00/KM	1,385.00
			<hr/>
			\$7,942.50

PHOENIX GEOPHYSICS LIMITED

Philip G. Hallof

Philip G. Hallof, Ph.D., P. Eng.
Geophysicist



Expiry Date: February 25, 1981

Dated: January 9, 1981

10 -
CERTIFICATE

I, Philip George Hallof, of the City of Toronto, Province of Ontario, do hereby certify that:

1. I am a geophysicist residing at Suite 3505, 2045 Lake Shore Blvd.W., Toronto, Ontario.
2. I am a graduate of the Massachusetts Institute of Technology with a B.Sc. Degree (1952) in Geology and Geophysics, and a Ph.D. Degree (1957) in Geophysics.
3. I am a member of the Society of Exploration Geophysicists and the European Association of the Exploration Geophysicists.
4. I am a Professional Geophysicist, registered in the Province of Ontario, the Province of British Columbia and the State of Arizona.
5. I have no direct or indirect interest, nor do I expect to receive any interest directly or indirectly, in the property or securities of Cordilleran Engineering Ltd., or any affiliate.
6. The statements made in this report are based on a study of published geological literature and unpublished private reports.
7. Permission is granted to use in whole or in part for assessment and qualification requirements but not for advertising purposes.

Dated at Toronto

This 9th day of January, 1981

Philip G. Hallof, Ph.D.



Expiry Date: February 25, 1981

CERTIFICATE

I, Paul A. Cartwright, of the City of Vancouver, Province of British Columbia, do hereby certify that:

1. I am a geophysicist residing at 4238 West 11th Avenue, Vancouver, B.C.
2. I am a graduate of the University of British Columbia, B.C. with a B.Sc. Degree.
3. I am a member of the Society of Exploration Geophysicists.
4. I have been practising my profession about 10 years.
5. I have no direct or indirect interest, nor do I expect to receive any interest directly or indirectly, in the property or securities of Cordilleran Engineering Ltd., or any affiliate.
6. The statements made in this report are based on a study of published geological literature and unpublished private reports.
7. Permission is granted to use in whole or in part for assessment and qualification requirements but not for advertising purposes.

Dated at Vancouver

This 9th day of January, 1981



Paul A. Cartwright, B.Sc.

CERTIFICATE

I, JOHN MARSH, of the Municipality of North York, Ontario, DO HEREBY CERTIFY THAT:

1. I am a geophysical crew leader residing at 200 Yorkland Blvd., Willowdale, Ontario.
2. I am a graduate of the City of Norwich Technical College, U.K., ordinary National Certificate (Electrical Engineering)
3. I worked with McPhar Geophysics Company from 1968 to 1975 as a geophysical crew leader.
4. I am presently employed as a geophysical crew leader by Phoenix Geophysics Ltd. of Suite 214 - 744 West Hastings Street, Vancouver, B.C.

Dated at Vancouver, B.C.

This 9th day of January, 1981

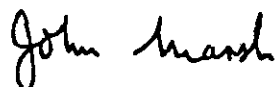

John Marsh

PHOENIX GEOPHYSICS LIMITED

INDUCED POLARIZATION AND RESISTIVITY SURVEY

PLAN MAP

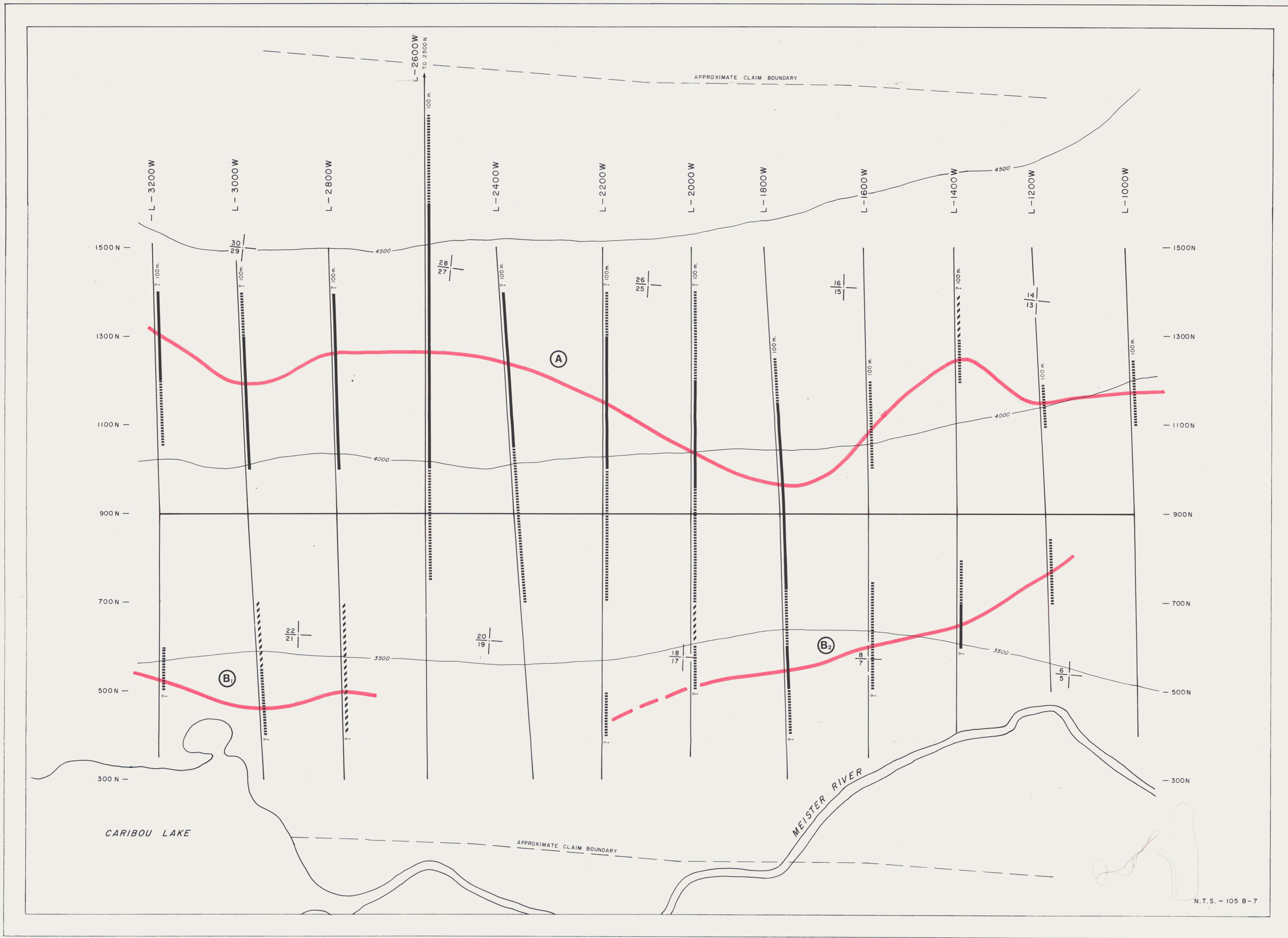

N.T.S. - 105 B - 7

CORDILLERAN ENGINEERING LTD.

CARIBOU CLAIM GROUP, WATSON LAKE M.D.

YUKON TERRITORY



SURFACE PROJECTION OF ANOMALOUS ZONE
 DEFINITE
 PROBABLE
 POSSIBLE
 NUMBER AT END OF ANOMALIES INDICATE SPREAD USED.

CLAIM POST LOCATION WITH NO. 1 POSTS

NOTE: ELEVATIONS ARE APPROXIMATE (Feet)

- AXIS OF ANOMALOUS I.P. ZONE

PROFESSIONAL
 REGISTERED
 ENGINEER
 OF
 YUKON TERRITORY
 APPROVED:
 G. HULL
 DATE: DEC 1980
 DATE: 12/9/81
 EXPIRY DATE: February 28, 1981

PHOENIX GEOPHYSICS LIMITED

MAGNETOMETER SURVEY

PLAN MAP

DWG NO. - M.P. - 3089

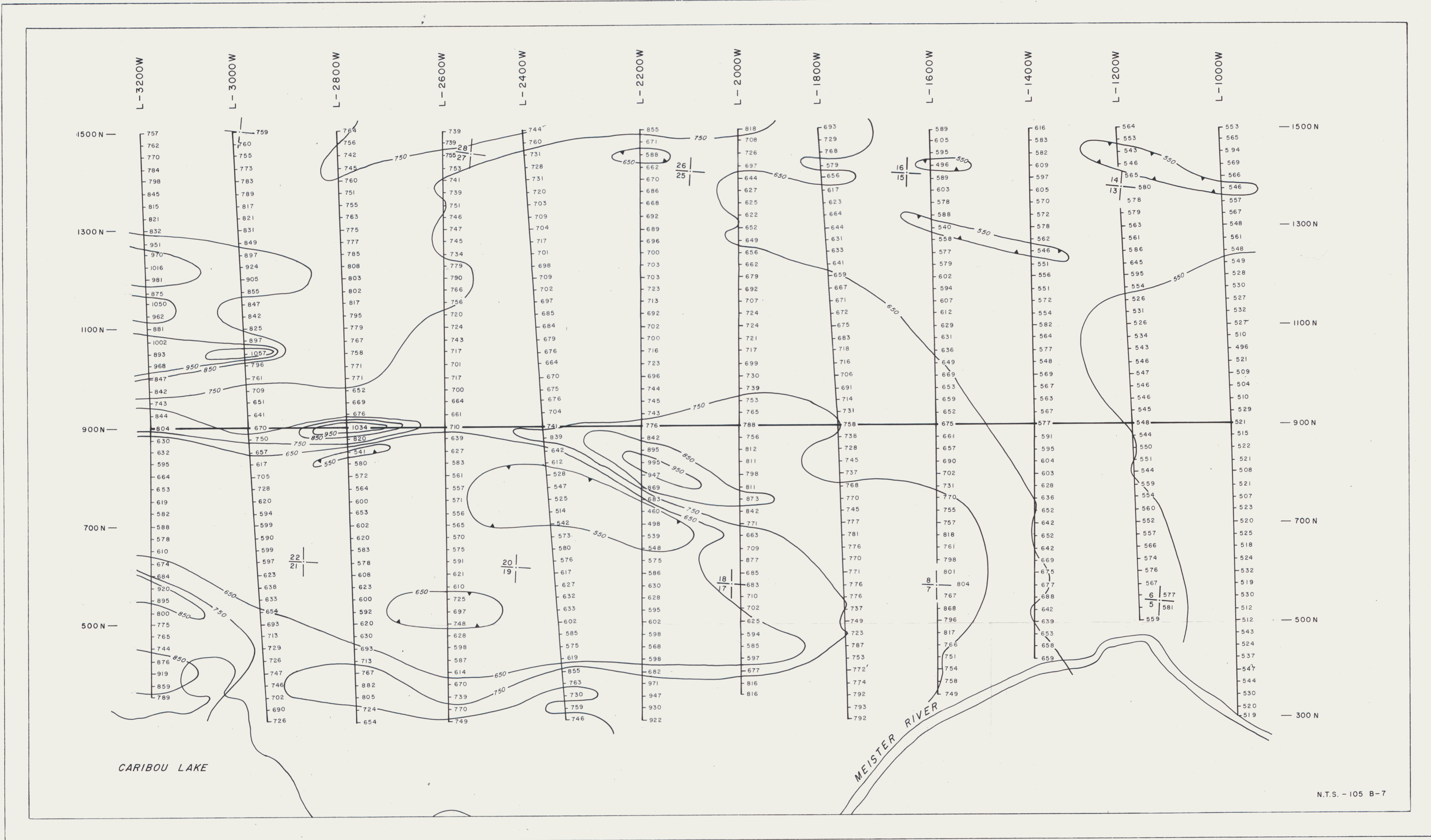

CARIBOU LAKE

MEISTER RIVER

N.T.S. - 105 B-7

CORDILLERAN ENGINEERING LTD.

CARIBOU CLAIM GROUP, WATSON LAKE M.D.

YUKON TERRITORY

16 | CLAIM POST LOCATION
15 | WITH NO. 1 POSTS

NOTE: CONTOUR INTERVAL: 100 Gammas
BASE VALUE: 58000 Gammas

SCALE
100 0 100 200 300 METRES

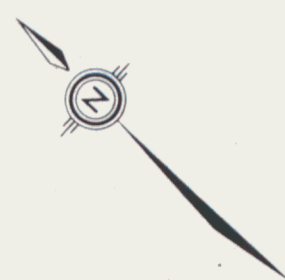

DRAWN: R.J.P.
DATE: DEC. 1980
APPROVED:
G. H. HALL
DATE: 1/19/81
Expiry Date: February 25, 1981

CORDILLERAN ENGINEERING LTD.

CARIBOU CLAIM GROUP, WATSON LAKE M.D.

YUKON TERRITORY

LINE NO. - 3200W

ELECTRODE CONFIGURATION

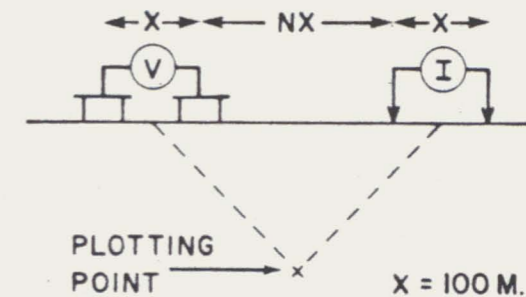

SURFACE PROJECTION OF ANOMALOUS ZONE

DEFINITE **—————**
 PROBABLE **.....**
 POSSIBLE **///////**

FREQUENCIES 0.3 - 5.0 HZ.

DATE SURVEYED JULY 1980

APPROVED

PROFESSIONAL
 PROVINCE OF
 BRITISH COLUMBIA
 ENGINEER
Philip A. Hall
 DATE 1/9/81

NOTE - CONTOURS AT LOGARITHMIC INTERVALS
 1, -1.5, -2, -3, -5, -7.5, -10

DATE

Expiry Date: February 25, 1981

PHOENIX GEOPHYSICS LIMITED

INDUCED POLARIZATION AND RESISTIVITY SURVEY

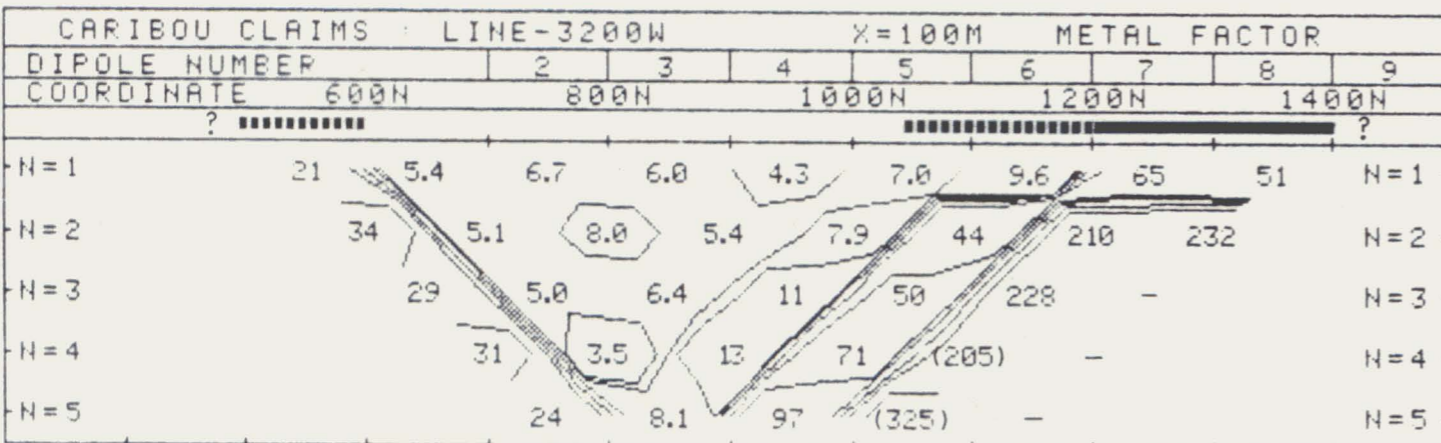
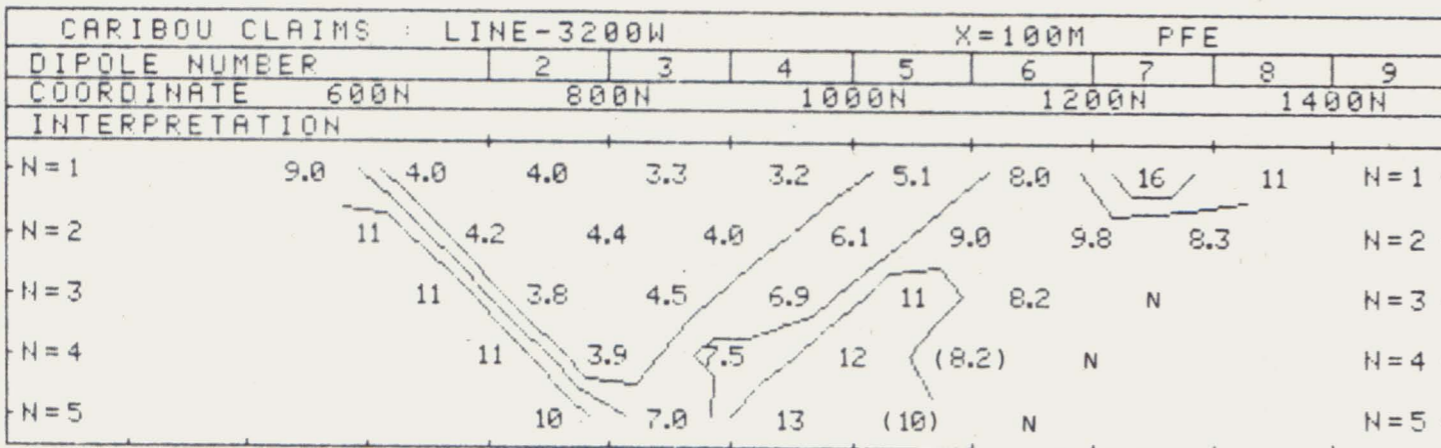
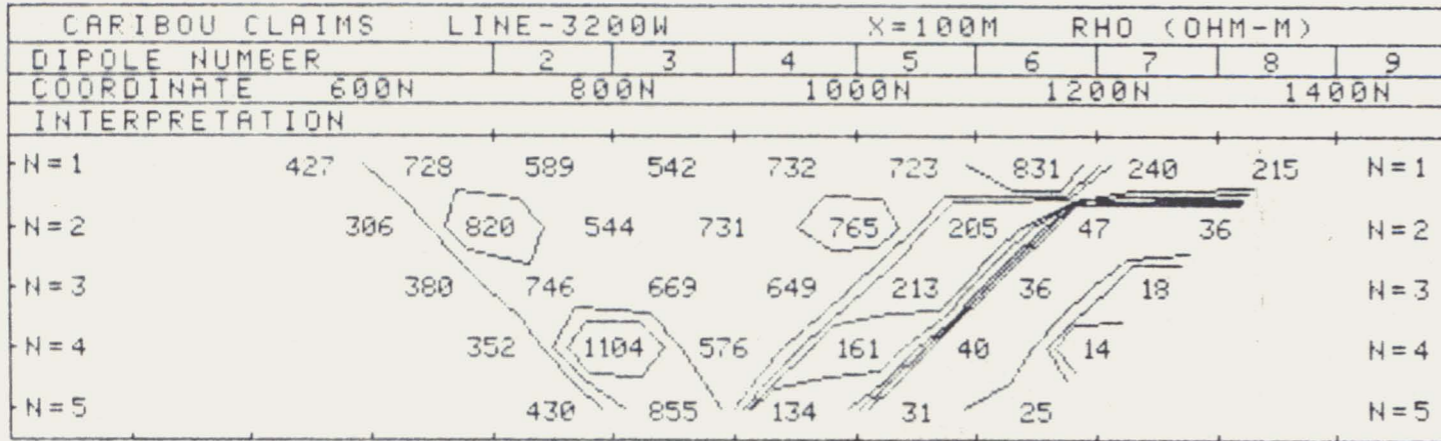

CORDILLERAN ENGINEERING LTD.

CARIBOU CLAIM GROUP, WATSON LAKE M.D.

YUKON TERRITORY

LINE NO. - 3000W

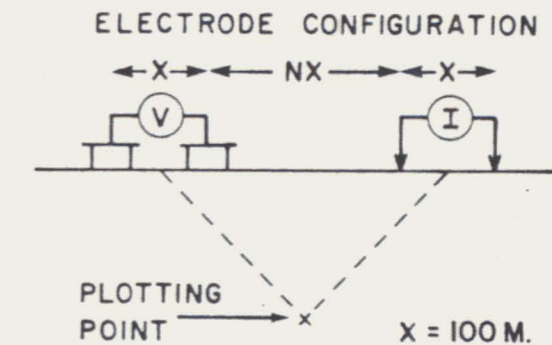

SURFACE PROJECTION OF ANOMALOUS ZONE

DEFINITE

PROBABLE

POSSIBLE

FREQUENCIES 0.3 - 5.0 HZ.

DATE SURVEYED 1 JULY 1980

APPROVED



NOTE - CONTOURS AT LOGARITHMIC INTERVALS 1, -1.5, -2, -3, -5, -7.5, -10

DATE 1/9/81

Expiry Date: February 25, 1981

PHOENIX GEOPHYSICS LIMITED

INDUCED POLARIZATION AND RESISTIVITY SURVEY

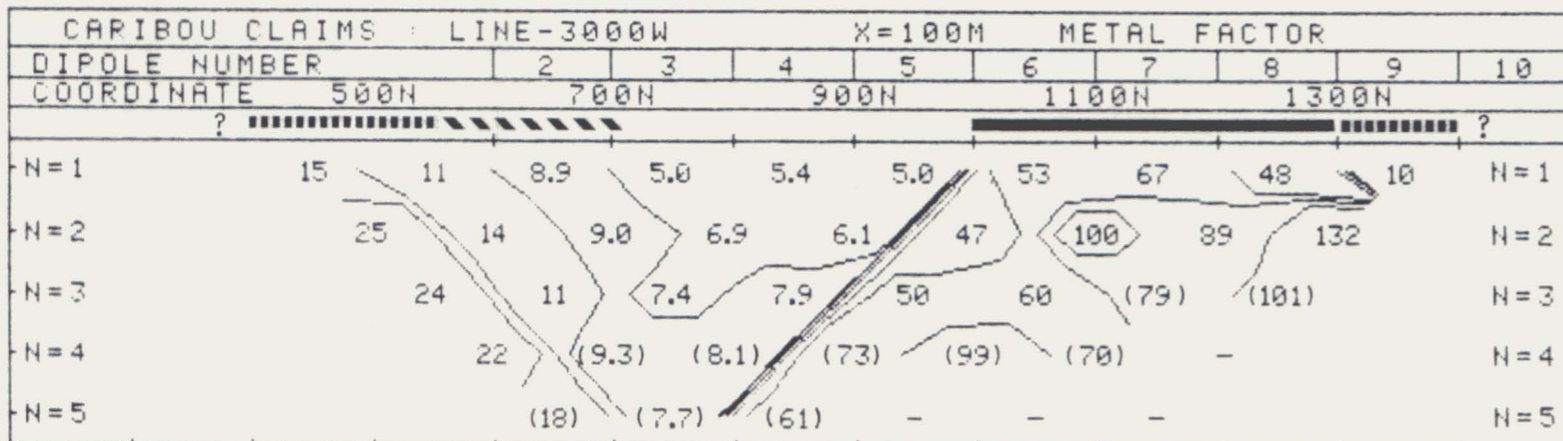
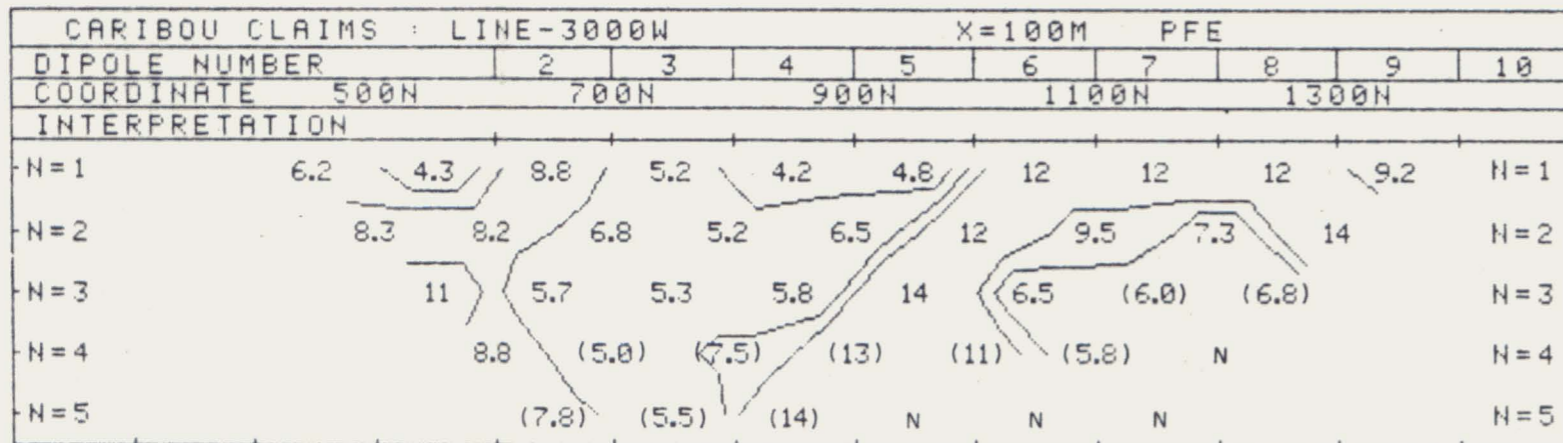
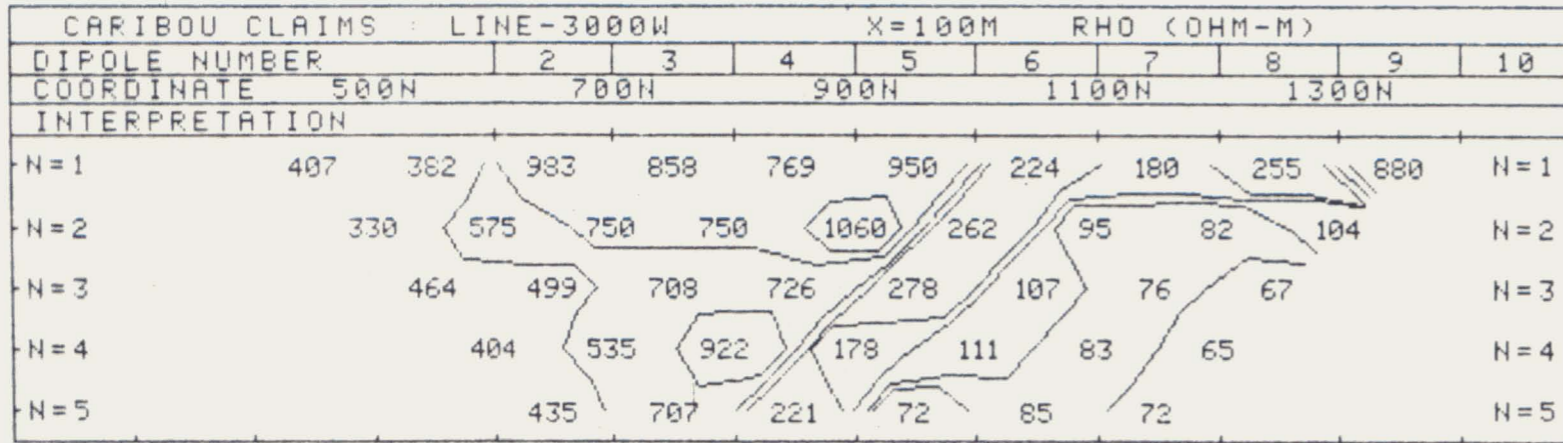

CORDILLERAN ENGINEERING LTD.

CARIBOU CLAIM GROUP, WATSON LAKE M.D.

YUKON TERRITORY

LINE NO. - 2800W

ELECTRODE CONFIGURATION

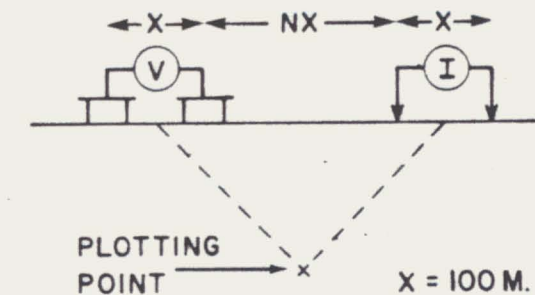

SURFACE PROJECTION OF ANOMALOUS ZONE

DEFINITE
 PROBABLE
 POSSIBLE

FREQUENCIES 0.3-5.0 HZ.

DATE SURVEYED JULY 1980

APPROVED

Philip L. Halgh
 P. L. HALGH
 BRITISH COLUMBIA
 ENGINEER

NOTE - CONTOURS AT LOGARITHMIC INTERVALS 1, -1.5, -2, -3, -5, -7.5, -10.

DATE 9/81

Expiry Date: February 25, 1981

PHOENIX GEOPHYSICS LIMITED

INDUCED POLARIZATION AND RESISTIVITY SURVEY

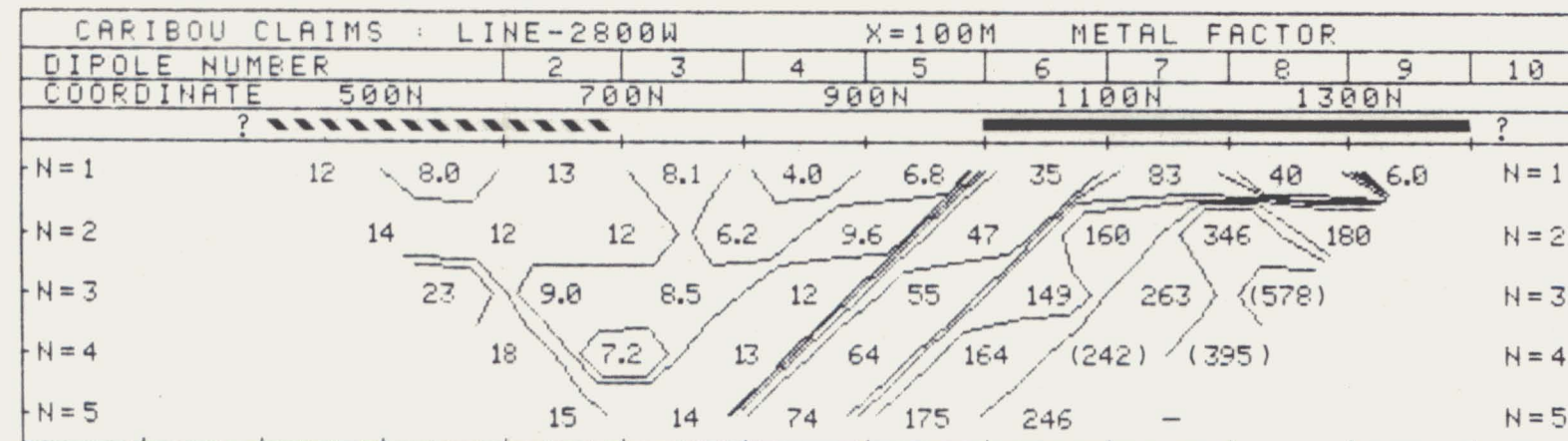
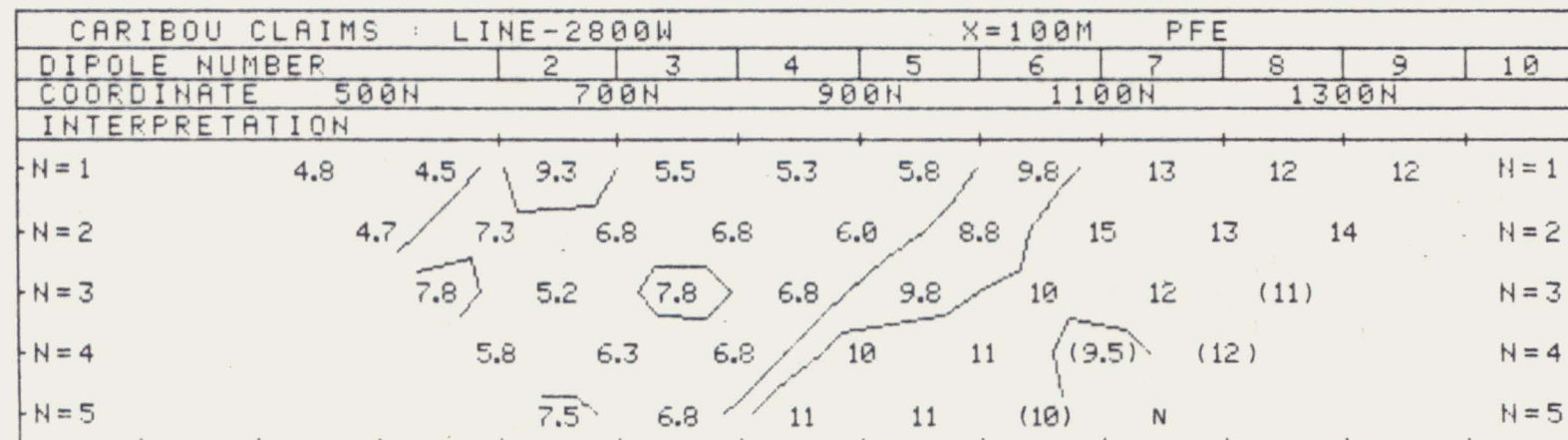
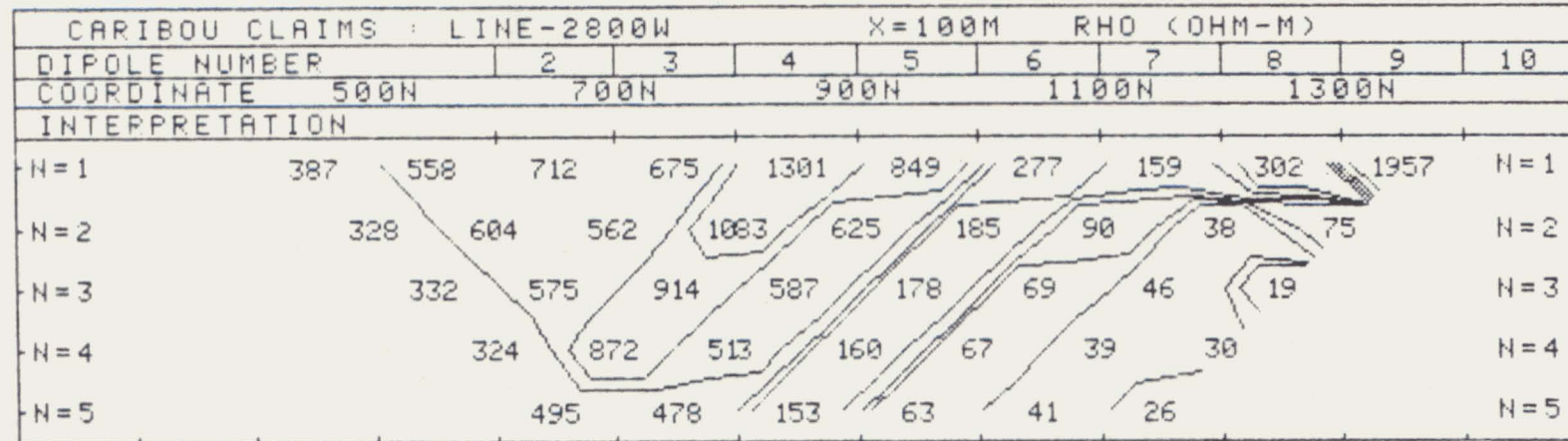

CORDILLERAN ENGINEERING LTD.

CARIBOU CLAIM GROUP, WATSON LAKE M.D.

YUKON TERRITORY

LINE NO. - 2600W

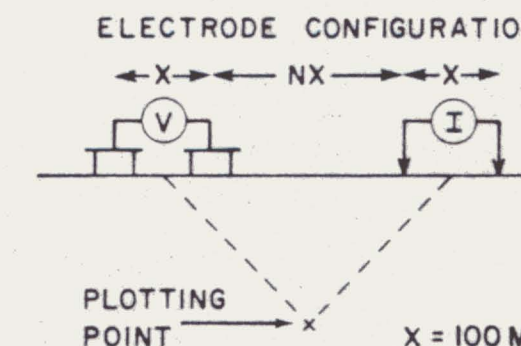

SURFACE PROJECTION OF ANOMALOUS ZONE

DEFINITE **—————**

PROBABLE **.....**

POSSIBLE **///////**

FREQUENCIES 0.3-5.0 HZ.

DATE SURVEYED JULY 1980

APPROVED

P. G. HALLOP
 P. G. HALLOP
 BRITISH COLUMBIA
 ELECTRICIAN
 1/9/81

NOTE - CONTOURS AT LOGARITHMIC INTERVALS 1, -1.5, -2, -3, -5, -7.5, -10

DATE

Expiry Date: February 25, 1981

PHOENIX GEOPHYSICS LIMITED

INDUCED POLARIZATION AND RESISTIVITY SURVEY

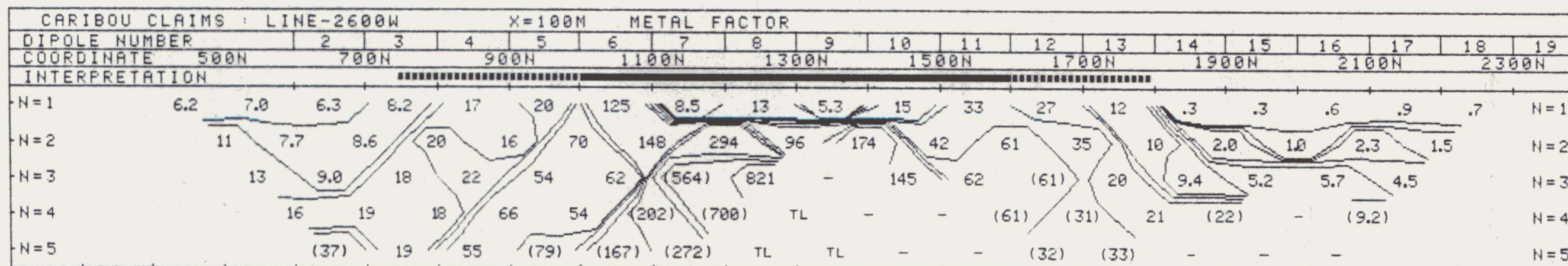
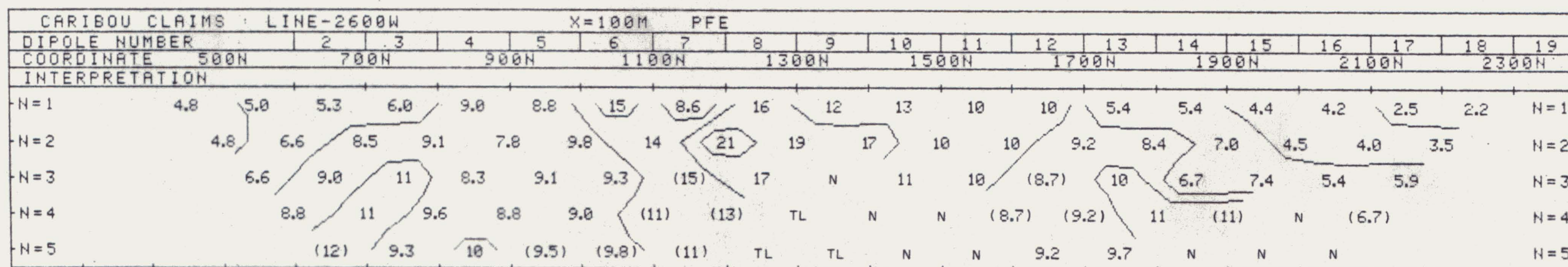
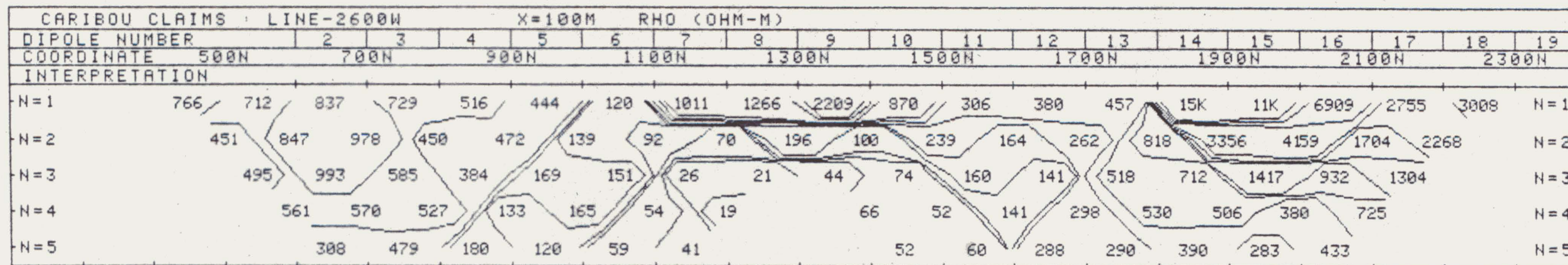

CORDILLERAN ENGINEERING LTD.

CARIBOU CLAIM GROUP, WATSON LAKE M.D.

YUKON TERRITORY

LINE NO. - 2400W

ELECTRODE CONFIGURATION

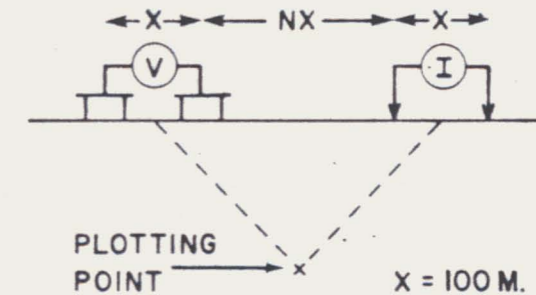

SURFACE PROJECTION OF ANOMALOUS ZONE

DEFINITE **—————**
 PROBABLE **.....**
 POSSIBLE **///////**

FREQUENCIES 0.3-5.0 HZ.

DATE SURVEYED JULY 1980

APPROVED

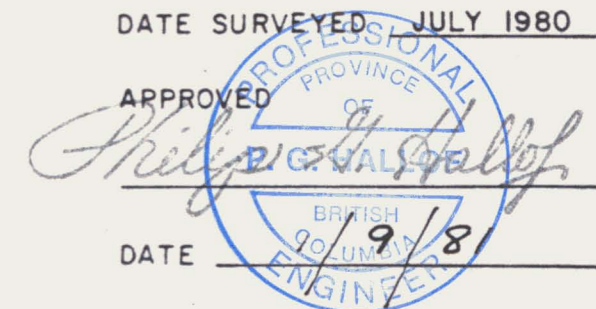

NOTE - CONTOURS AT LOGARITHMIC INTERVALS 1, -1.5, -2, -3, -5, -7.5, -10

DATE

Expiry Date: February 25, 1981

PHOENIX GEOPHYSICS LIMITED

INDUCED POLARIZATION AND RESISTIVITY SURVEY

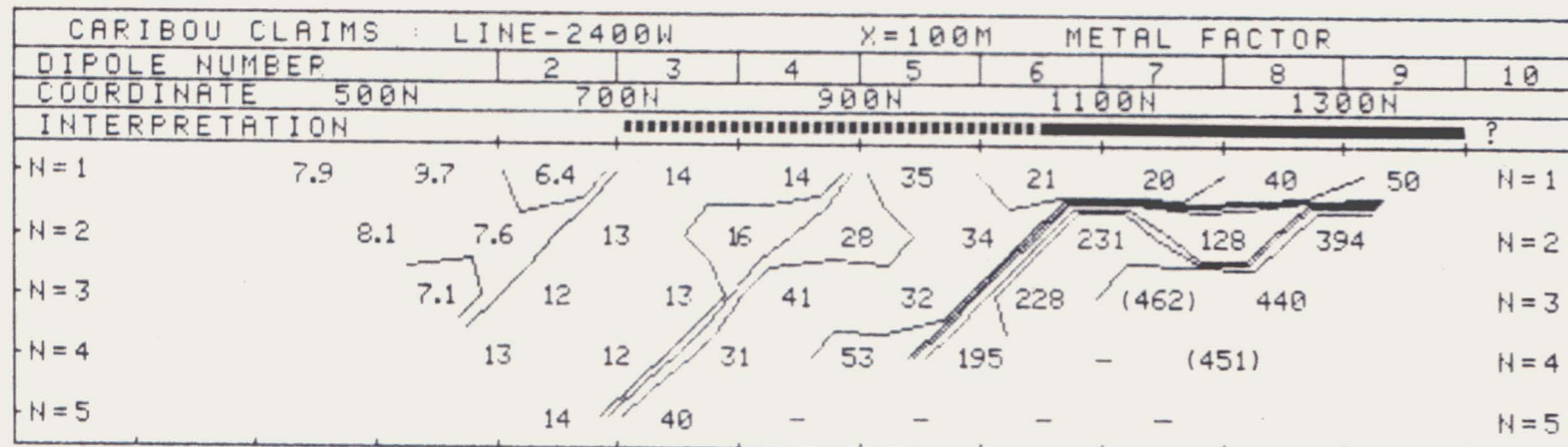
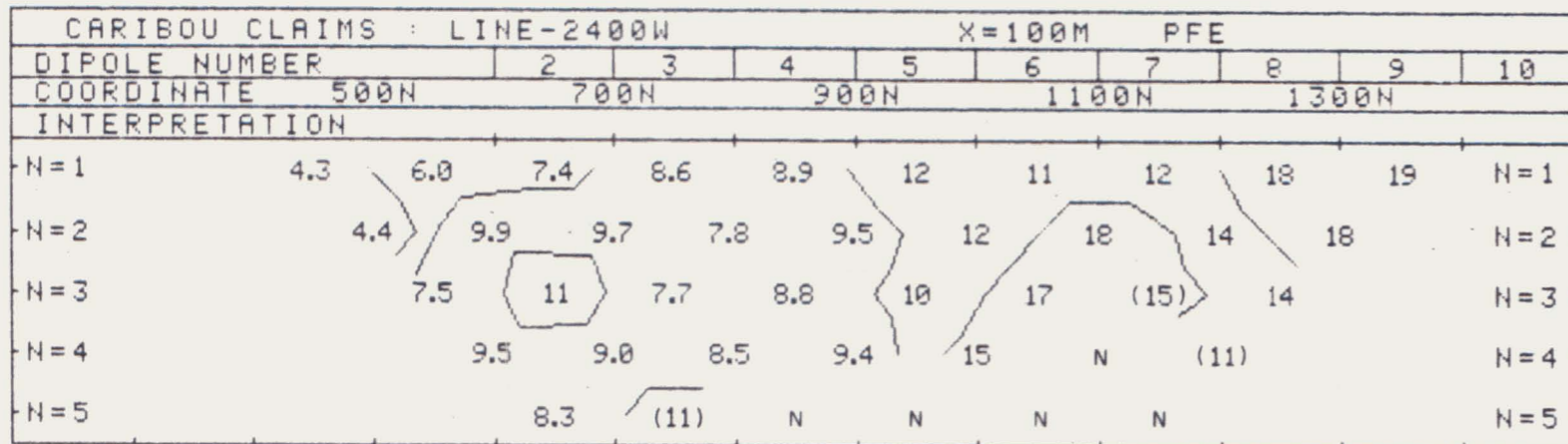
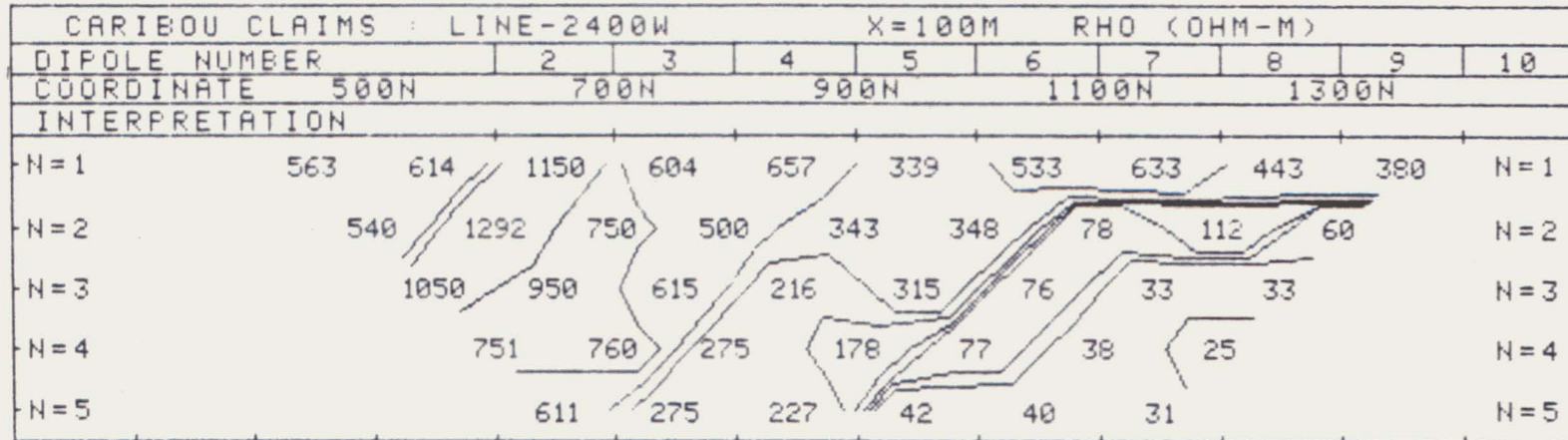

CORDILLERAN ENGINEERING LTD.

CARIBOU CLAIM GROUP, WATSON LAKE M.D.

YUKON TERRITORY

LINE NO. - 2200W

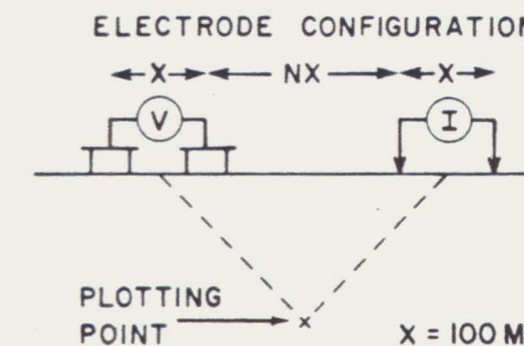

SURFACE PROJECTION OF ANOMALOUS ZONE

DEFINITE **—————**
 PROBABLE **.....**
 POSSIBLE **///////**

FREQUENCIES 0.3-5.0 HZ.

DATE SURVEYED JULY 1980

APPROVED

Philip S. Hallett
 B. G. HALDOP
 BRITISH COLUMBIA ENGINEER

DATE

19/81
 Expiry Date: February 25, 1981

NOTE - CONTOURS AT LOGARITHMIC INTERVALS 1, -1.5, -2, -3, -5, -7.5, -10

PHOENIX GEOPHYSICS LIMITED

INDUCED POLARIZATION AND RESISTIVITY SURVEY

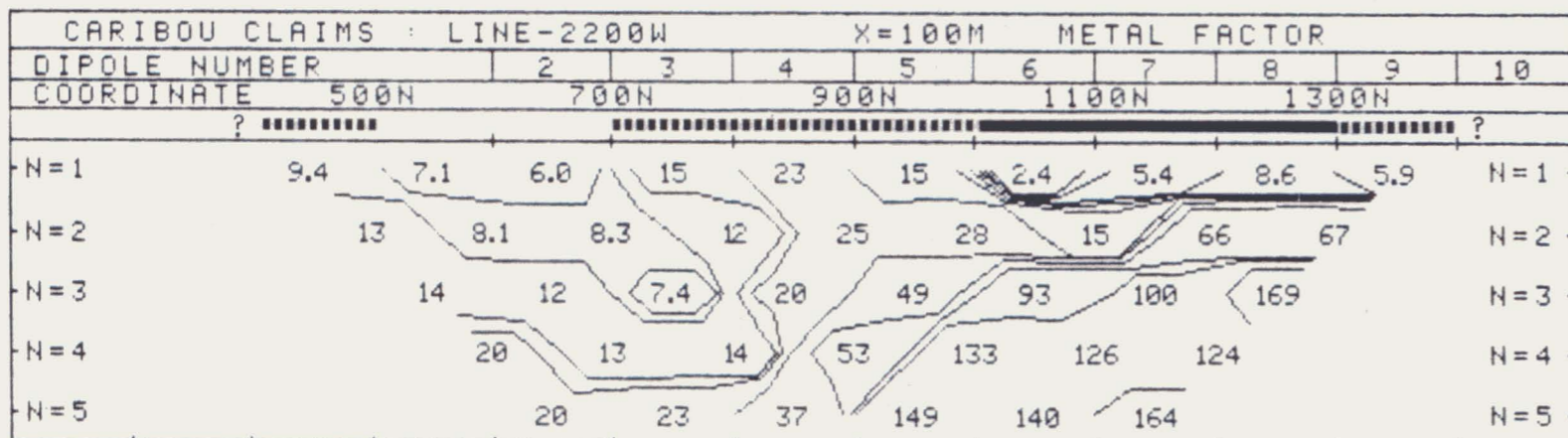
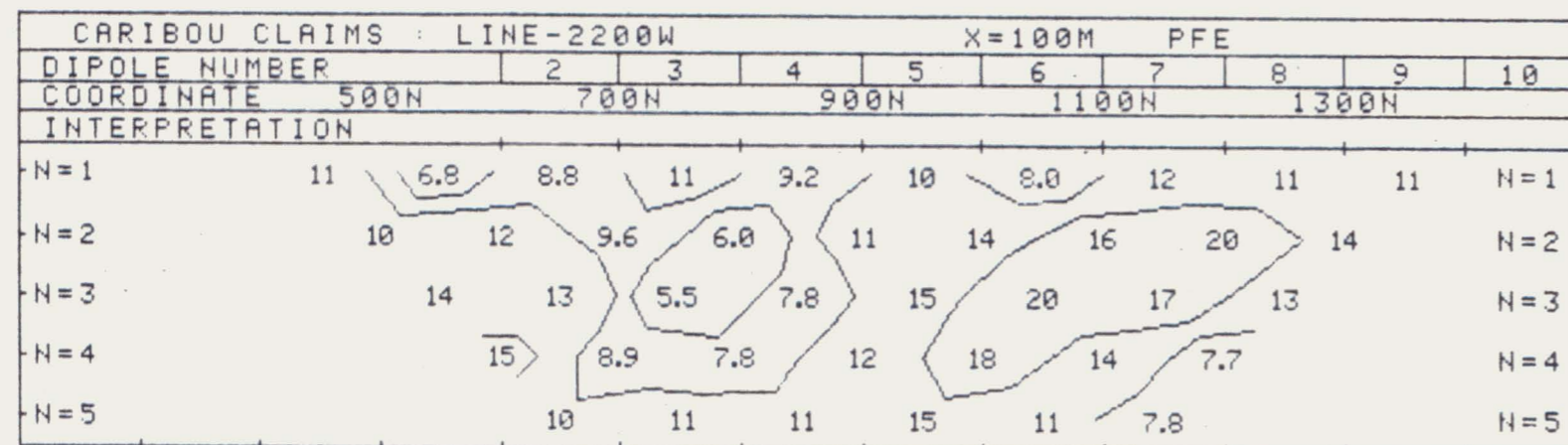
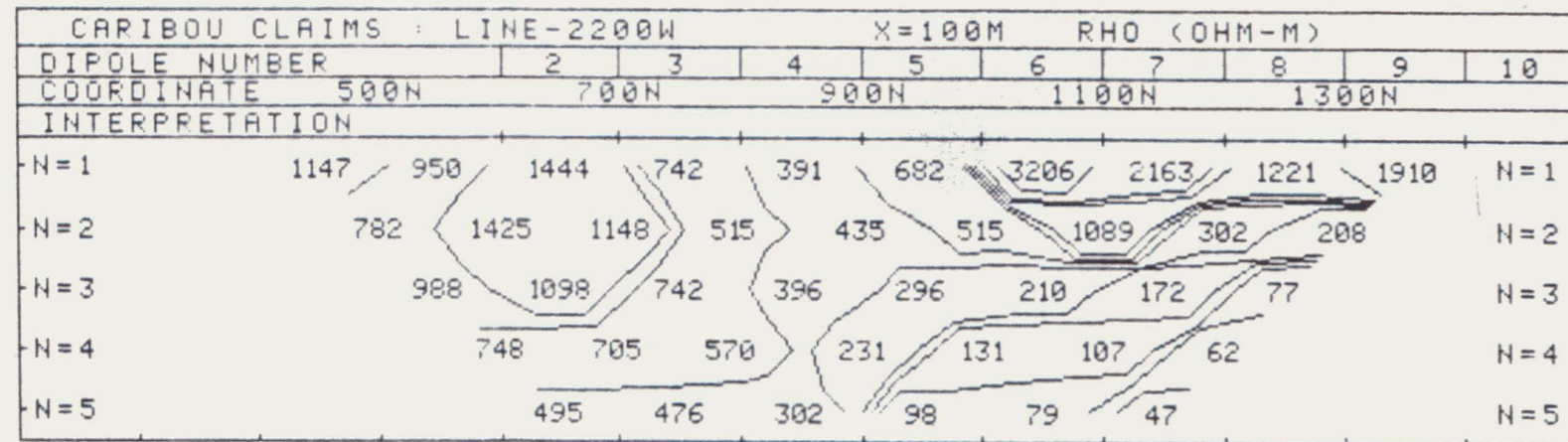

CORDILLERAN ENGINEERING LTD.

CARIBOU CLAIM GROUP, WATSON LAKE M.D.

YUKON TERRITORY

LINE NO. - 2000W

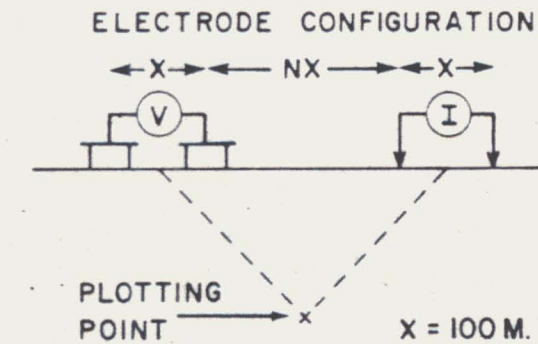

SURFACE PROJECTION OF ANOMALOUS ZONE

DEFINITE **—————**
 PROBABLE **.....**
 POSSIBLE **///////**

FREQUENCIES 0.3-5.0 HZ.

DATE SURVEYED JULY 1980

APPROVED
Philip S. Halper
 BRITISH COLUMBIA ENGINEER
 DATE 1/9/81

NOTE - CONTOURS AT LOGARITHMIC INTERVALS 1, -1.5, -2, -3, -5, -7.5, -10

Expiry Date: February 25, 1981

PHOENIX GEOPHYSICS LIMITED

INDUCED POLARIZATION AND RESISTIVITY SURVEY

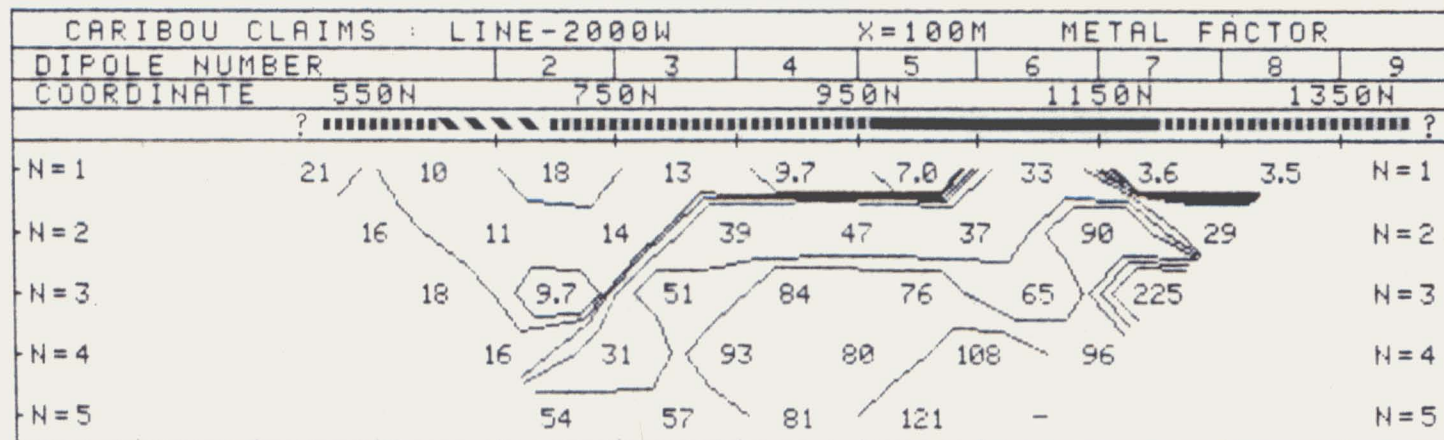
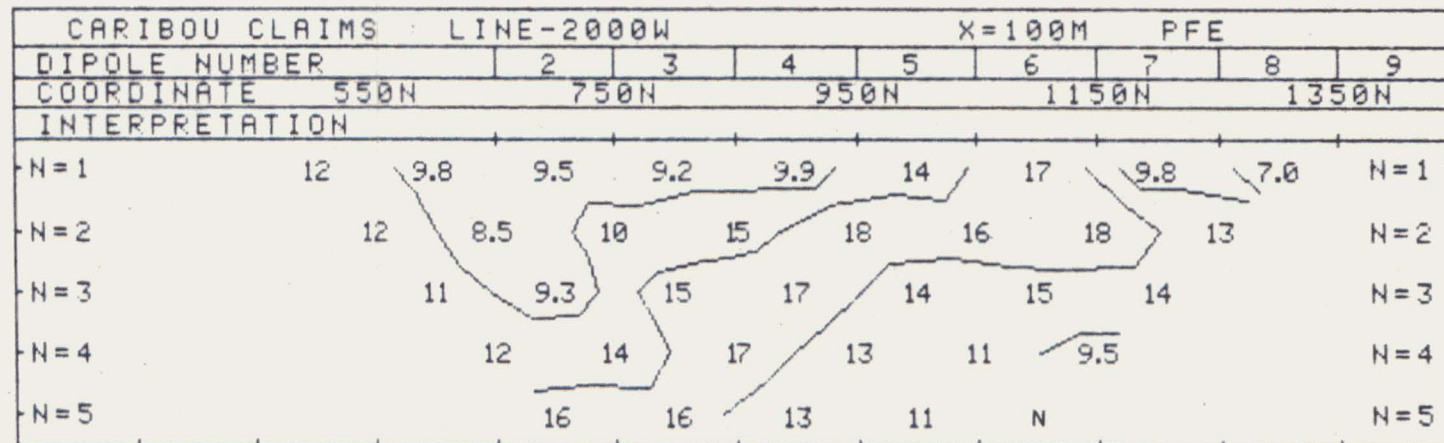
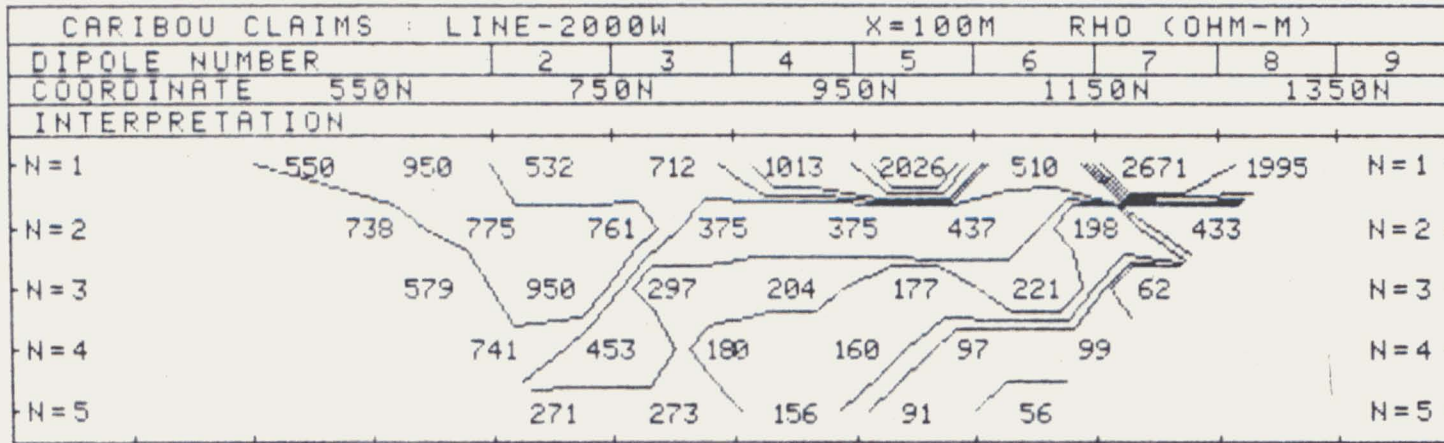

CORDILLERAN ENGINEERING LTD.

CARIBOU CLAIM GROUP, WATSON LAKE M.D.

YUKON TERRITORY

LINE NO. - 1800W

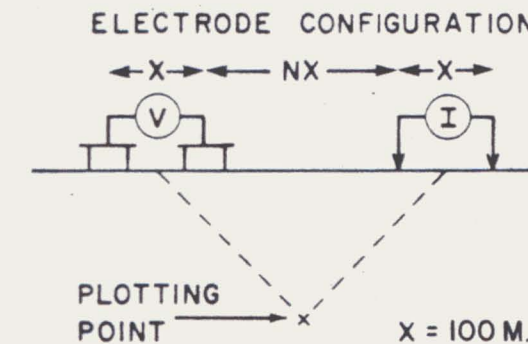

SURFACE PROJECTION OF ANOMALOUS ZONE

DEFINITE **—————**
 PROBABLE **.....**
 POSSIBLE **///////**

FREQUENCIES 0.3-5.0 HZ.

DATE SURVEYED JULY 1980

APPROVED

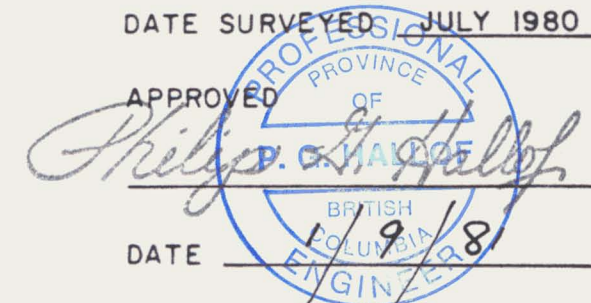

NOTE - CONTOURS AT LOGARITHMIC INTERVALS 1, -1.5, -2, -3, -5, -7.5, -10

DATE

Expiry Date: February 25, 1981

PHOENIX GEOPHYSICS LIMITED

INDUCED POLARIZATION AND RESISTIVITY SURVEY

CARIBOU CLAIMS		LINE-1800W		X=100M		RHO (OHM-M)				
DIPOLE NUMBER	2	3	4	5	6	7	8	9	10	
COORDINATE	500N	700N	900N	1100N	1300N					
INTERPRETATION										
N=1	701	263	567	791	1045	779	775	644	2067	902
N=2	322	398	421	348	246	358	321	326	1036	
N=3	424	332	356	105	181	247	305	165		
N=4	340	310	162	126	183	239	200			
N=5	305	99	212	123	200	154				

CARIBOU CLAIMS		LINE-1800W		X=100M		PFE				
DIPOLE NUMBER	2	3	4	5	6	7	8	9	10	
COORDINATE	500N	700N	900N	1100N	1300N					
INTERPRETATION										
N=1	11	12	11	8.8	11	10	12	9.7	5.9	5.7
N=2	13	14	14	13	18	17	12	13	10	
N=3	14	14	14	14	16	13	11	16		
N=4	14	13	15	13	11	12	12			
N=5	13	(9.0)	15	9.4	11	12				

CARIBOU CLAIMS		LINE-1800W		X=100M		METAL FACTOR				
DIPOLE NUMBER	2	3	4	5	6	7	8	9	10	
COORDINATE	500N	700N	900N	1100N	1300N					
?										
N=1	16	45	19	11	11	13	16	15	2.8	6.3
N=2	40	35	33	36	71	46	36	39	9.8	
N=3	33	42	38	132	88	87	36	96		
N=4	41	42	95	100	60	51	61			
N=5	42	(91)	71	76	53	76				

CORDILLERAN ENGINEERING LTD.

CARIBOU CLAIM GROUP, WATSON LAKE M.D.

YUKON TERRITORY

LINE NO. - 1600W

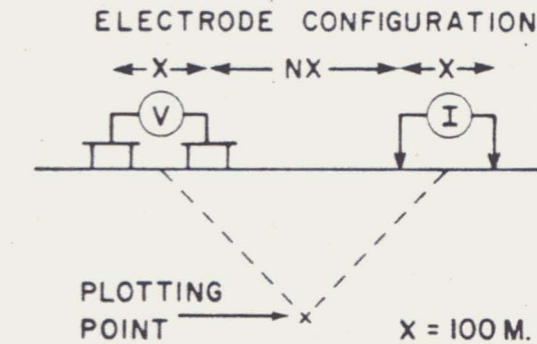

SURFACE PROJECTION OF ANOMALOUS ZONE

DEFINITE **—————**
 PROBABLE **.....**
 POSSIBLE **///////**

FREQUENCIES 0.3 - 5.0 HZ.

DATE SURVEYED JULY 1980

APPROVED *Philip S. Halley*
 PROFESSIONAL ENGINEER
 PROVINCE OF BRITISH COLUMBIA
 DATE 1/9/81

NOTE - CONTOURS AT LOGARITHMIC INTERVALS 1, -1.5, -2, -3, -5, -7.5, -10

Expiry Date: February 25, 1981

PHOENIX GEOPHYSICS LIMITED

INDUCED POLARIZATION AND RESISTIVITY SURVEY

CARIBOU CLAIMS		LINE-1600W							X=100M		RHO (OHM-M)	
DIPOLE NUMBER		2	3	4	5	6	7	8	9			
COORDINATE		600N	800N	1000N	1200N	1400N						
INTERPRETATION												
N=1		433	659	1017	1108	950	606	950	1122	1646	N=1	
N=2		354	395	437	562	340	500	792	607		N=2	
N=3		256	245	276	287	344	422	377			N=3	
N=4		174	210	214	311	351	238				N=4	
N=5		157	194	265	348	253					N=5	

CARIBOU CLAIMS		LINE-1600W							X=100M		PFE	
DIPOLE NUMBER		2	3	4	5	6	7	8	9			
COORDINATE		600N	800N	1000N	1200N	1400N						
INTERPRETATION												
N=1		11	17	12	10	8.7	8.7	6.0	6.0	4.2	N=1	
N=2		12	14	16	15	11	8.8	10	8.7		N=2	
N=3		9.0	13	16	14	11	13	12			N=3	
N=4		(9.0)	11	12	14	12	13				N=4	
N=5		(8.5)	7.5	11	14	12					N=5	

CARIBOU CLAIMS		LINE-1600W							X=100M		METAL FACTOR	
DIPOLE NUMBER		2	3	4	5	6	7	8	9			
COORDINATE		600N	800N	1000N	1200N	1400N						
INTERPRETATION												
N=1		25	26	12	9.2	9.1	14	6.3	5.3	2.5	N=1	
N=2		34	35	36	27	31	18	13	14		N=2	
N=3		35	52	57	48	33	31	31			N=3	
N=4		52	54	54	44	34	54				N=4	
N=5		(54)	(39)	41	39	46					N=5	

CORDILLERAN ENGINEERING LTD.

CARIBOU CLAIM GROUP, WATSON LAKE M.D.

YUKON TERRITORY

LINE NO. - 1400W

ELECTRODE CONFIGURATION

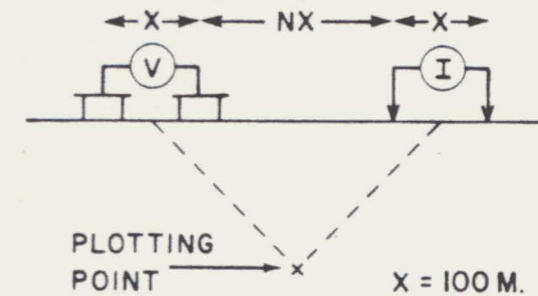

SURFACE PROJECTION OF ANOMALOUS ZONE

DEFINITE
 PROBABLE
 POSSIBLE

FREQUENCIES 0.3-5.0 HZ.

DATE SURVEYED JULY 1980

APPROVED

Philip P. Hall
 PROVINCE OF BRITISH COLUMBIA
 REGISTERED ELECTRICAL ENGINEER
 1/9/81

NOTE - CONTOURS AT LOGARITHMIC INTERVALS 1, -1.5, -2, -3, -5, -7.5, -10

DATE

Expiry Date: February 25, 1984

PHOENIX GEOPHYSICS LIMITED

INDUCED POLARIZATION AND RESISTIVITY SURVEY

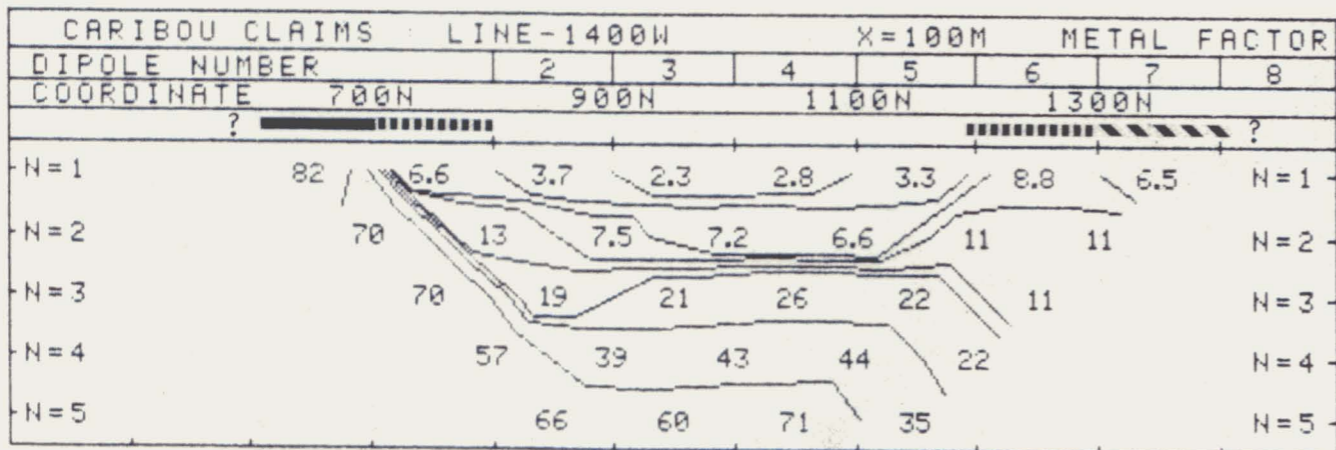
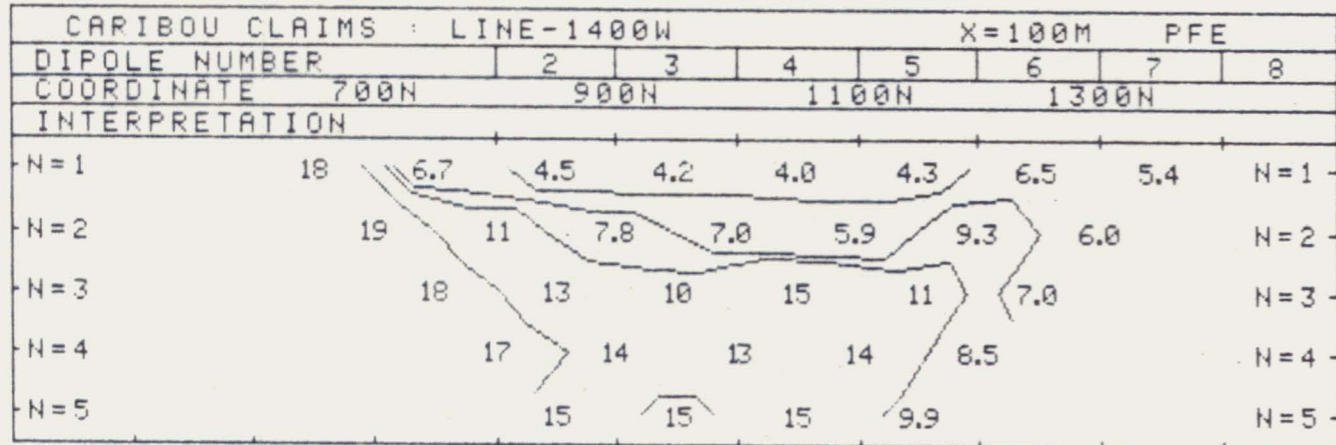
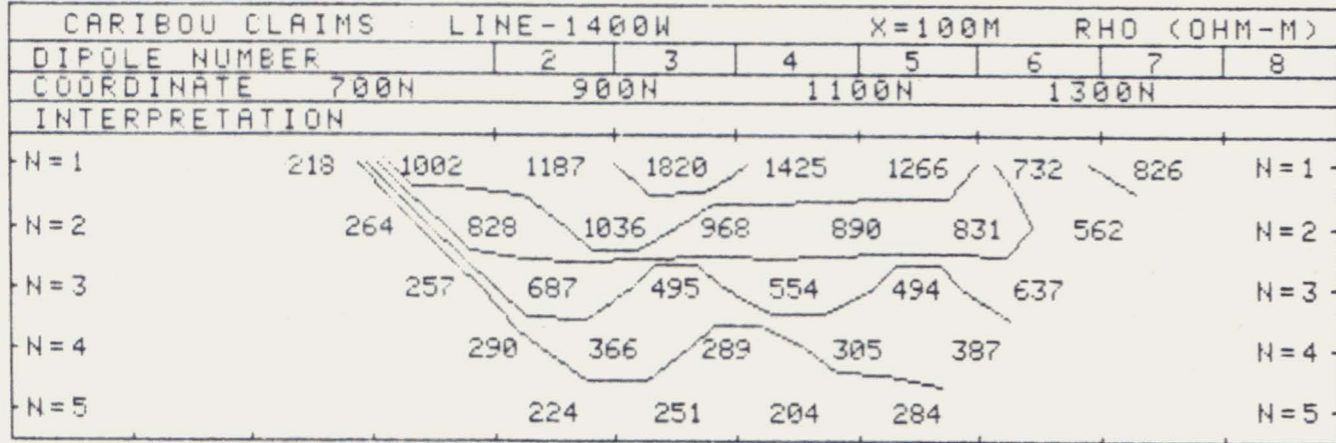

CORDILLERAN ENGINEERING LTD.

CARIBOU CLAIM GROUP, WATSON LAKE M.D.

YUKON TERRITORY

LINE NO. - 1200W

ELECTRODE CONFIGURATION

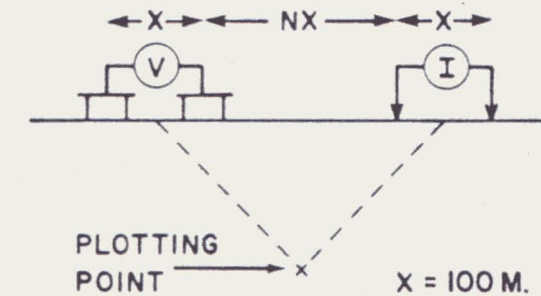

SURFACE PROJECTION OF ANOMALOUS ZONE

DEFINITE **—————**
 PROBABLE **.....**
 POSSIBLE **///////**

FREQUENCIES 0.3 - 5.0 HZ.

DATE SURVEYED JULY 1980

APPROVED

Philip G. Hallock
 BRITISH COLUMBIA ENGINEER

NOTE - CONTOURS AT LOGARITHMIC INTERVALS 1, -1.5, -2, -3, -5, -7.5, -10

DATE

Expiry Date: February 25, 1981

PHOENIX GEOPHYSICS LIMITED

INDUCED POLARIZATION AND RESISTIVITY SURVEY

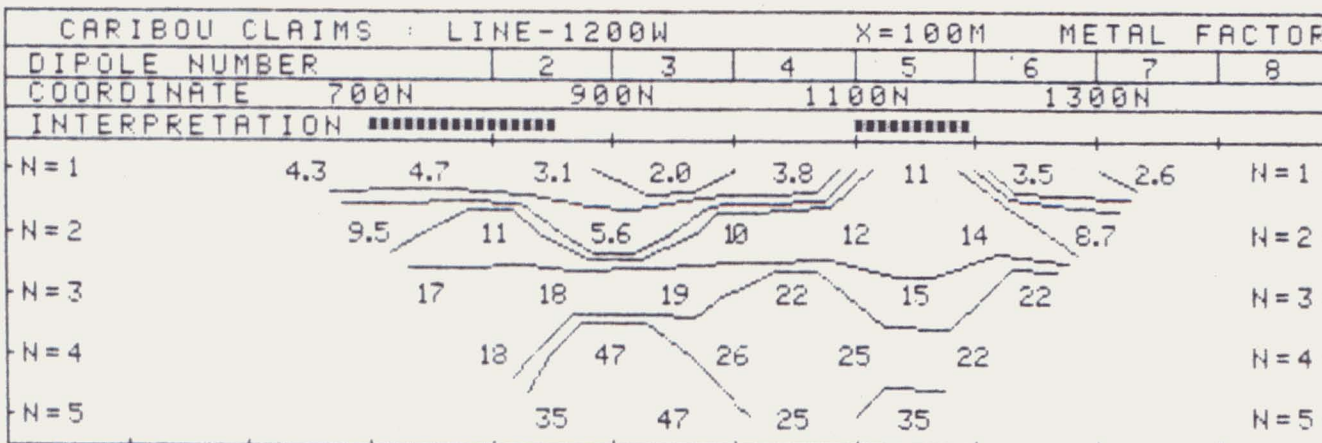
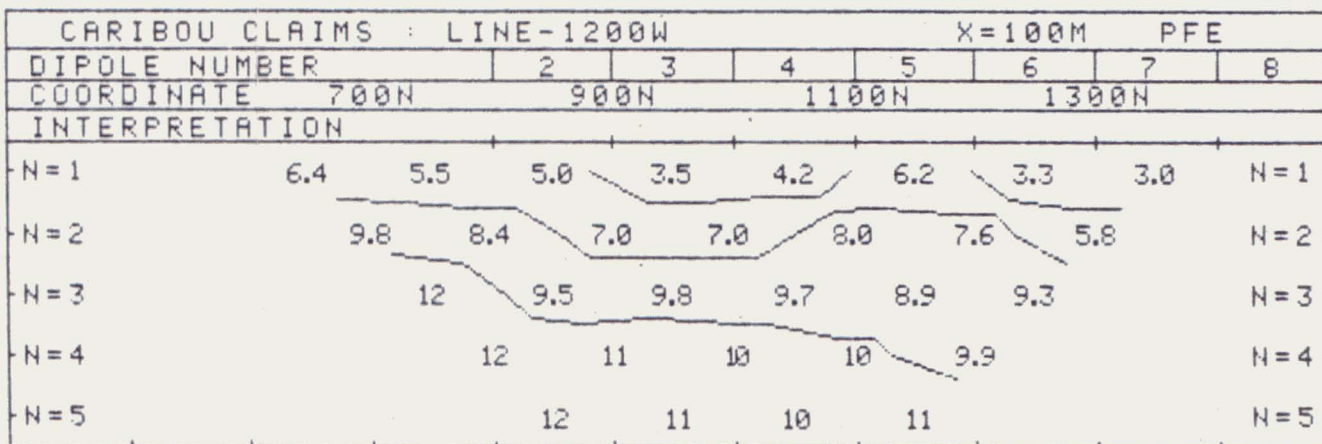
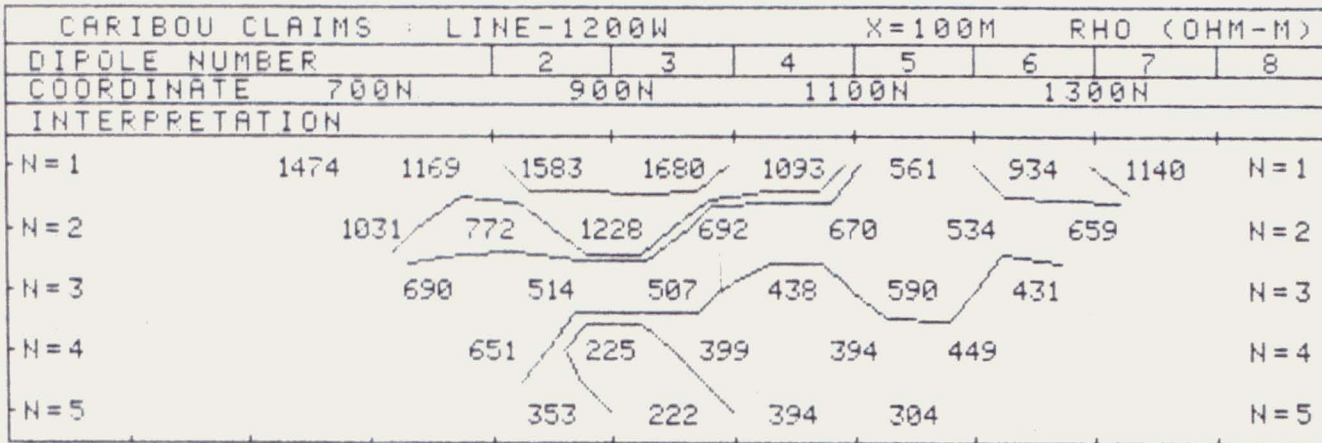

CORDILLERAN ENGINEERING LTD.

CARIBOU CLAIM GROUP, WATSON LAKE M.D.

YUKON TERRITORY

LINE NO. - 1000W

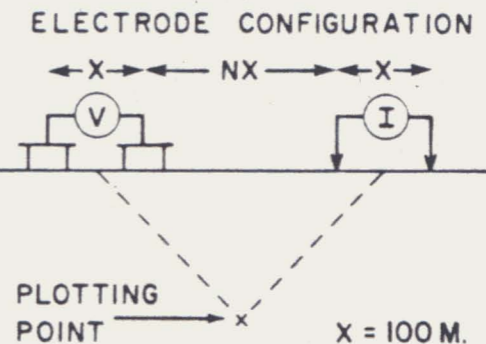

SURFACE PROJECTION OF ANOMALOUS ZONE
 DEFINITE **—————**
 PROBABLE **.....**
 POSSIBLE **///////**

FREQUENCIES 0.3-5.0 HZ.

DATE SURVEYED JULY 1980

APPROVED

Philip S. Hall
 P. S. HALL
 BRITISH COLUMBIA
 PROFESSIONAL ENGINEER

NOTE - CONTOURS AT LOGARITHMIC INTERVALS
 1, -1.5, -2, -3, -5, -7.5, -10

DATE

19/81
 Expiry Date: February 25, 1981

PHOENIX GEOPHYSICS LIMITED

INDUCED POLARIZATION AND RESISTIVITY SURVEY

CARIBOU CLAIMS : LINE-1000W		X=100M RHO (OHM-M)							
DIPOLE NUMBER	2	3	4	5	6	7	8		
COORDINATE	700N	900N	1100N	1300N					
INTERPRETATION									
N=1	1002	1448	1258	1198	814	665	801	1393	N=1
N=2	768	834	727	535	660	577	486		N=2
N=3	500	633	326	475	588	399			N=3
N=4	419	305	367	425	393				N=4
N=5	218	363	321	290					N=5

CARIBOU CLAIMS : LINE-1000W		X=100M PFE							
DIPOLE NUMBER	2	3	4	5	6	7	8		
COORDINATE	700N	900N	1100N	1300N					
INTERPRETATION									
N=1	3.5	2.3	4.0	3.8	4.5	7.0	6.0	3.2	N=1
N=2	5.8	7.4	7.0	8.3	8.0	7.1	7.9		N=2
N=3	8.9	8.0	11	10	8.0	8.1			N=3
N=4	8.9	11	9.2	9.2	9.3				N=4
N=5	11	9.0	9.0	9.8					N=5

CARIBOU CLAIMS : LINE-1000W		X=100M METAL FACTOR							
DIPOLE NUMBER	2	3	4	5	6	7	8		
COORDINATE	700N	900N	1100N	1300N					
INTERPRETATION									
N=1	3.4	1.5	3.1	3.1	5.5	11	7.4	2.2	N=1
N=2	7.5	8.8	9.6	15	12	12	16		N=2
N=3	18	13	32	21	14	20			N=3
N=4	21	34	25	22	24				N=4
N=5	50	25	28	34					N=5