

REPORT ON THE
COMBINED GEOPHYSICAL SURVEYS
ON THE
EAGLE CLAIM GROUP

WATSON LAKE MINING DISTRICT
LITTLE MOOSE RIVER AREA, YUKON TERRITORY
N.T.S. 105B/8
60°26'N, 130°26'W

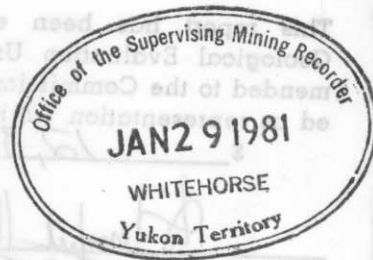

FOR

CORDILLERAN ENGINEERING



BY

Paul A. Cartwright, B.Sc., Geophysicist
and

Philip G. Hallof, Ph.D., P.Eng., Geophysicist

PHOENIX GEOPHYSICS LIMITED
214 - 744 West Hastings Street
Vancouver, B.C. V6C 1A6

JANUARY, 1981

CLAIMS: Eagle Mineral Claims, Numbers 1 to 32 inclusive
LOCATION: 106 km (66 mi) northwest of Watson Lake, Y.T.
DATE: June 28 to July 13, 1980

090715

This report has been examined by the Geological Evaluation Unit and is recommended to the Commissioner to be considered as representation work in the amount of \$ 12,800.00

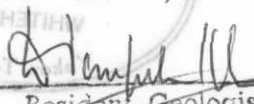
Resident Geologist or
Resident Mining Engineer

Considered as representation work under Section 53 (4) Yukon Quartz Mining Act.

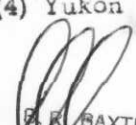
B. R. BAXTER
Commissioner of Yukon Territory



CORDILLERAN ENGINEERING

By

Paul A. Cartwright, B.Sc., Geophysicist
and
Phillip G. Halliwell, Ph.D., P.Eng., Geophysicist

PHOENIX GEOPHYSICS LIMITED
214 - 7th West Hastings Street
Vancouver, B.C. V6C 1A6

JANUARY, 1981

CLAIMS: Eagle Mineral Claims, Numbers 1 to 32 inclusive
LOCATION: 106 km (66 mi) northwest of Watson Lake, Y.T.
DATE: June 28 to July 13, 1980

090712

TABLE OF CONTENTS

| | | | |
|--------------------|-------------------------------|-----------------------------|-------------|
| <u>Part A:</u> | Report | 14 pages | <u>Page</u> |
| 1. | Introduction | | 1 |
| 2. | Description of the Claims | | 2 |
| 3. | Presentation of Results | | 3 |
| 4. | Discussion of Results | | 6 |
| 5. | Summary And Conclusions | | 9 |
| 6. | Assessment Details | | 11 |
| 7. | Statement of Cost | | 12 |
| 8. | Certificate - P.A. Cartwright | | 13 |
| 9. | Certificate - P.G. Hallof | | 14 |
| <u>Part B:</u> | Illustrations | 28 pieces | |
| | Plan Map (in pocket) | Dwg. I.P.P. 4085 | |
| | IP Data Plots | Dwg.No. IP 5238-1 to -17 | |
| | VLF-EM | Dwg.No. VLF-EM 5239-1 to -5 | |
| | MAG | Dwg. No. MAG 5240-1 to -5 | |

PHOENIX GEOPHYSICS LIMITED

REPORT ON THE
COMBINED GEOPHYSICAL SURVEYS
ON THE
EAGLE CLAIM GROUP
WATSON LAKE MINING DISTRICT
YUKON TERRITORY
FOR
CORDILLERAN ENGINEERING LTD.

1. INTRODUCTION

A program of Induced Polarization, VLF Electromagnetic, and Total Field Magnetic surveying has been completed on the Eagle Claim Group, Watson Lake Mining Division, for Cordilleran Engineering Ltd.

The property is situated approximately 100 km. west-northwest of the town of Watson Lake, Yukon Territory, N.T.S. 105 B-8. Access was via charter aircraft from Watson Lake.

Mineralized float containing Cu, Pb, Zn and Ag was discovered beside a gossan on the banks of the Little Moose River. A short geophysical orientation program was then completed during October 1979. Induced Polarization, Vertical Loop Electromagnetic and Vertical Field Magnetic

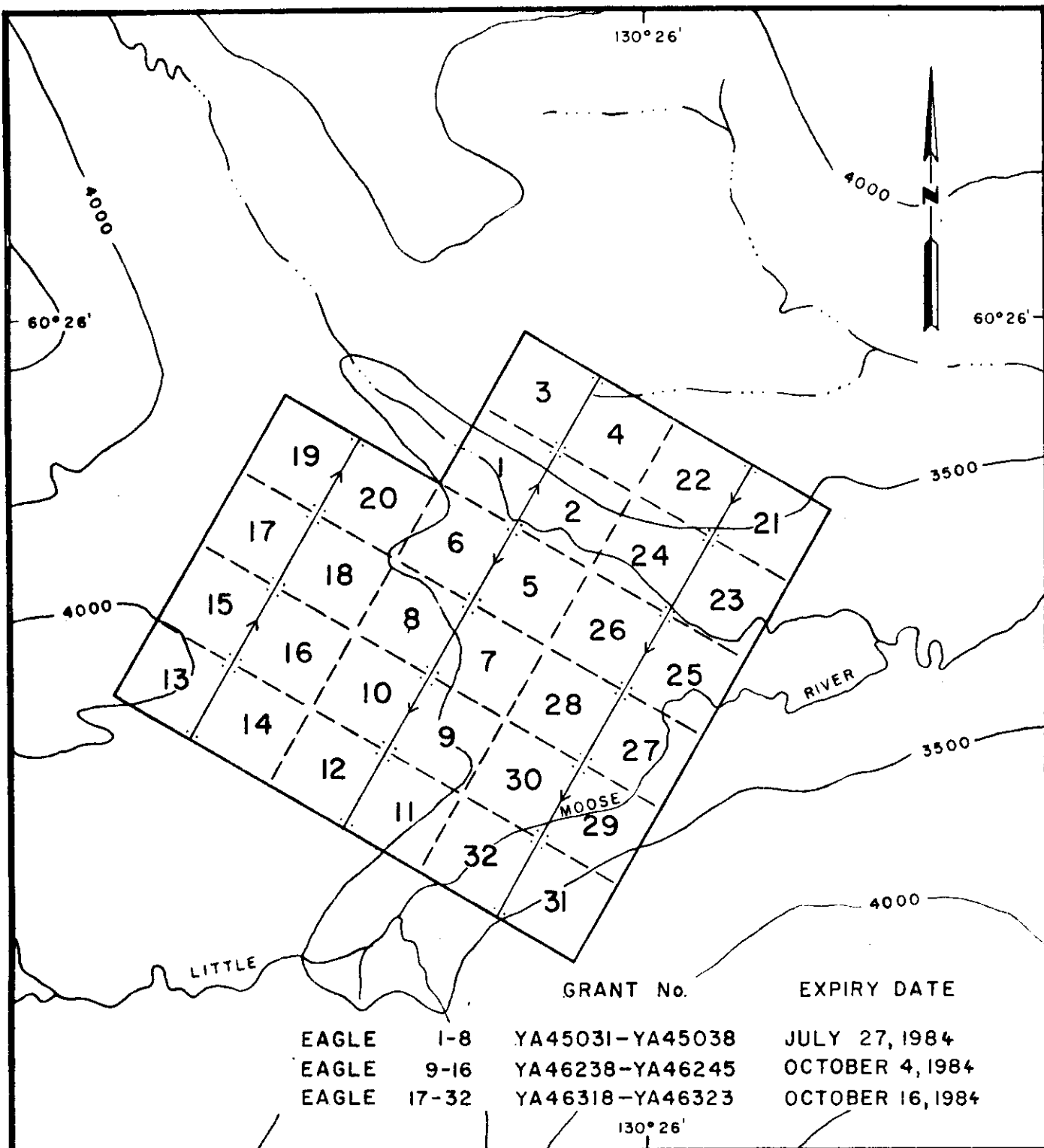

CLAIM MAP

EAGLE GROUP

WATSON LAKE MINING DISTRICT, YUKON TERRITORY

N.T.S. 105B-8

SCALE: 1 inch = 1/2 mile

CONTOUR INTERVAL = 500 feet

techniques were utilized to survey one line very close to the showing. While the IP method detected an anomalous response over the area of interest, the other two methods did not appear to respond. Therefore, the present program employed IP and Resistivity, VLF-EM and Total Field Proton Magnetics.

The reader is referred to the report by this author, dated January 9, 1980, which describes the geophysical orientation program on the Logan, Eagle, and Wolf claim groups, for additional information regarding the geology and previous work.

A Phoenix Model IPV-1, IPT-1 frequency domain IP system, operating at 5.0 Hz, and 0.31 Hz, was used to make the induced polarization and resistivity measurements, while a McPhar Model GP-70 proton magnetometer, together with a McPhar Model M-700 base station recorder were utilized for the magnetic readings. A Phoenix Model VLF-2 EM receiver was employed to record the VLF-EM results.

All surveys were carried out under the supervision of Mr. John Marsh, Senior Crew Leader. His certificate of qualification is appended to this report.

Field work on the Eagle Claim Group was completed during June 1980.

2. DESCRIPTION OF THE CLAIMS

| | <u>Grant No.</u> | <u>Expiry Date</u> |
|---------------|------------------|--------------------|
| Eagle 1 - 8 | YA45031-YA45038 | July 27, 1984 |
| Eagle 9 - 16 | YA46238-YA46245 | October 4, 1984 |
| Eagle 17 - 32 | YA46318-YA46323 | October 16, 1984 |

The reader is referred to Figure 3, a claim map of the property.

3. PRESENTATION OF RESULTS

The results of the geophysical surveys are shown on the following data plots. The induced polarization and resistivity data are plotted in pseudo-section form, while the VLF-EM and magnetometer data are presented as profiles.

| <u>Line</u> | <u>Electrode Interval</u> | <u>Dwg. No.</u> |
|-------------|---------------------------|-----------------|
| 1400W | 100M | IP 5238-1 |
| 1200W | 100M | IP 5238-2 |
| 1000W | 100M | IP 5238-3 |
| 800W | 100M | IP 5238-4 |
| 600W | 100M | IP 5238-5 |
| | 50M | IP 5238-6 |
| 400W | 100M | IP 5238-7 |
| 200W | 100M | IP 5238-8 |
| 0 | 100M | IP 5238-9 |
| 200E | 100M | IP 5238-10 |
| | 50M | IP 5238-11 |
| 390E | 100M | IP 5238-12 |
| 600E | 100M | IP 5238-13 |
| 800E | 100M | IP 5238-14 |
| 1000E | 100M | IP 5238-15 |
| 1200E | 100M | IP 5238-16 |
| 1400E | 100M | IP 5238-17 |

| <u>Line</u> | <u>Measurement Interval</u> | <u>Dwg. No.</u> |
|-------------|-----------------------------|-----------------|
| 1400W | 25M | VLF-EM 5239-1 |
| 1200W | 25M | VLF-EM 5239-1 |
| 1000W | 25M | VLF-EM 5239-1 |
| 800W | 25M | VLF-EM 5239-2 |
| 600W | 25M | VLF-EM 5239-2 |
| 400W | 25M | VLF-EM 5239-2 |
| 200W | 25M | VLF-EM 5239-3 |
| 0 | 25M | VLF-EM 5239-3 |
| 200E | 25M | VLF-EM 5239-3 |
| 390E | 25M | VLF-EM 5239-4 |
| 600E | 25M | VLF-EM 5239-4 |
| 800E | 25M | VLF-EM 5239-4 |
| 1000E | 25M | VLF-EM 5239-5 |
| 1200E | 25M | VLF-EM 5239-5 |
| 1400E | 25M | VLF-EM 5239-5 |
| 1400W | 25M | MAG 5240-1 |
| 1200W | 25M | MAG 5240-1 |
| 1000W | 25M | MAG 5240-1 |
| 800W | 25M | MAG 5340=2 |
| 600W | 25M | MAG 5240-2 |
| 400W | 25M | MAG 5240-2 |
| 200W | 25M | MAG 5240-3 |
| 0 | 25M | MAG 5240-3 |
| 200E | 25M | MAG 5240-3 |

| <u>Line</u> | <u>Measurement Interval</u> | <u>Dwg. No.</u> |
|-------------|-----------------------------|-----------------|
| 390E | 25M | MAG 5240-4 |
| 600E | 25M | MAG 5240-4 |
| 800E | 25M | MAG 5240-4 |
| 1000E | 25M | MAG 5240-5 |
| 1200E | 25M | MAG 5240-5 |
| 1400E | 25M | MAG 5240-5 |

Also included with this report is Dwg. I.P.P. 4085, a plan map of the Eagle Claims grid. The definite, probable, and possible IP and Resistivity, and EM anomalies are indicated by symbols, in the manner shown on the legend, on this plan map as well as on the data plots. Locations of points of peak magnetic amplitude are also marked on plan map Dwg. I.P.P. 4085.

The grid information shown on Dwg. I.P.P. 4085, has been taken from maps made available by the staff of Cordilleran Engineering Ltd.

4. DISCUSSION OF RESULTS

Most of the Eagle Claims grid appears to be underlain by rock units displaying moderate to moderately low resistivity values, such as would be expected from biotite-muscovite-quartz schist. However, much more competent rocks are apparently present along both the northern and southern ends of the grid lines as evidenced by the much higher than normal apparent resistivity values recorded on the extreme ends of some of the lines. The contact between the schists and the more resistive rocks is apparently often marked by anomalous VLF-EM responses as well, especially along the northern margin, although in these instances the actual contact location is most probably displaced 25 meters to 50 meters further to the north from the VLF-EM anomaly symbol.

A number of continuous, anomalous zones have been interpreted in the IP data. However, none of the five IP zones outlined are accompanied by apparent resistivity values low enough in magnitude to suggest the presence of large amounts of concentrated metallic sulphides. This is consistent with the VLF-EM results, which generally show only weakly anomalous indications over the areas of interesting IP response. All of the IP zones do display moderate to high magnitude polarization effects which, together with the moderately low resistivity values, point to large amounts of disseminated metallic mineralization being present.

Each of the IP trends is marked on plan map I.P.P. 4085 and is discussed separately below. Where applicable, VLF-EM and Total Field Magnetic results are included in the discussion.

IP ZONE A

This is the most encouraging response outlined on the Eagle Claims

grid, as the zone passed directly through the area of the gossan and anomalous float. IP Zone A is interpreted to extend from the vicinity of Line 0+00 to beyond the most easterly line surveyed, Line 1400E.

Magnetic results from some of the lines surveyed across the IP zone indicate magnetic minerals such as magnetite or pyrrhotite may constitute some of the IP source. However, the two most anomalous IP signatures are seen on Line 200E and Line 390E, where no correlating magnetic highs are present. Detail IP coverage has been completed on Line 200E, and the source of the IP response is indicated to extend well within 50 meters of the surface. As is the case of all of the IP zones detected by this survey, only moderately low apparent resistivity values can be seen accompanying the quite anomalous polarizability values. Zinc mineralization, if present in significant amounts could contribute to higher than normal apparent resistivity values being recorded.

The anomalous values seen in the data from Line 200E form a pattern which suggests the source is either depth limited, or very narrow.

IP ZONE B

IP Zone B is interpreted to trend from the area of the northern end of Line 600W to beyond Line 1400W. A definitely anomalous VLF-EM response is recorded coincident with the IP anomaly detected on Line 600W, however, no interesting magnetic features are noted correlating with Zone B at any point along its length.

Detail IP coverage using 50 meter dipole lengths has been completed on Line 600W, and a very shallow target is indicated. Depth to the top of the source would not exceed 25 meters, while the width is indicated to

be less than 100 meters. Depth extent is most probably quite limited as well. The source of this IP anomaly is the most conductive of those registered by the present survey.

IP ZONE C

The source of this anomalous IP trend appears to be in the order of several hundred meters in width, and to lie at a depth of less than 50 meters subsurface. Disseminated metallic mineralization is the probable source material, although magnetite may be contributing to the response as a number of narrow bands of weakly magnetic material are seen within the area of the IP zone. Weakly anomalous VLF-EM signatures also present correlating with the central part of the zone, while two definitely anomalous VLF-EM features are indicated on the extreme southern ends of Line 1400W and Line 1200W. It is highly probable these two strong EM anomalies are primarily due to a change of rock type from the schists to a more resistive unit to the south.

IP Zone C appears to strike into IP Zone B in the vicinity of Line 800W, however, the exact relationship of the two zones is unclear.

IP ZONE D

A relatively wide body of primarily disseminated mineralization is seen as the probable cause of this anomalous IP zone, which is detected on the southern end of Line 200W through to the vicinity of the southernmost part of Line 800E.

No correlating zone of VLF-EM response is evident in the data, while low amplitude magnetic anomalies are indicated on all of the survey lines which cross IP Zone D. Magnetite or pyrrhotite is probably

present, although it is not likely that magnetic minerals are the primary cause of the IP response.

Depth to the top of the IP source should not exceed 50 meters sub-surface.

IP ZONE E

This zone is indicated to lie on the southeastern portion of the grid area, with the most anomalous responses being seen in the IP data from Line 1200E and Line 1400E. In all cases, the sources of the IP anomalies appear to be several hundred meters in width, less than 50 meters in depth, and are probably caused by substantial amounts of mainly disseminated metallic mineralization. The zone is open towards the east, and does not appear to have any correlating magnetic features or VLF-EM anomalies.

5. SUMMARY AND CONCLUSIONS

A combined geophysical survey program has been completed on the Eagle Claims grid, using Induced Polarization and Resistivity, VLF-EM, and Total Field Magnetism.

While five discreet anomalous IP zones are outlined by the data, the only well defined zone of VLF-EM anomalies appears to show the northern contact between the schists which underly most of the grid area, and a more resistive rock type lying to the north of the grid area.

The total field magnetic values reveal that distribution of magnetic minerals is sporadic in the grid area. In some cases magnetic minerals may be contributing to the anomalous IP effects measured.

IP Zone A is the most encouraging trend detected by the present

survey as it passes very close to the discovery gossan, and the mineralized float located in the same area. Drill testing of this zone is recommended on a first priority basis. A diamond drill hole, spotted so as to pass 35 meters beneath Line 200E, Station 3+10N, is recommended.

IP Zone B would be a second priority drill target, mainly due to the fact the resistivity of the zone may be somewhat lower than the other zones encountered. A drill hole located so as to pass through a point no more than 25 meters below Line 600W, Station 5+50N is recommended.

IP ZONE C, IP ZONE D, IP ZONE E

Physical testing of these zones should be delayed until results of the drilling on IP Zone A and IP Zone B become known, as the sources of all the zones appear to be quite similar.

PHOENIX GEOPHYSICS LIMITED

Paul A. Cartwright

Paul A. Cartwright, B.Sc.
Geophysicist

Philip G. Hallof

Philip G. Hallof, Ph.D., P.Eng.
Geophysicist

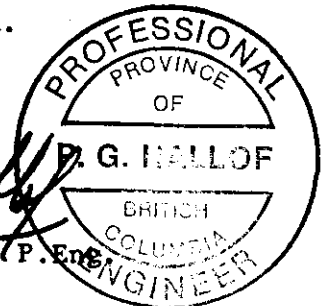

Expiry Date: February 25, 1981

Dated: January 7, 1981

STATEMENT OF COST

Cordilleran Engineering Limited - Eagle Claims - Contract Number PV-1049
Geophysical Surveys, Watson Lake M.D., Y.T.

CREW: J. Marsh - G. Ouellette

PERIOD: June 28 - July 13, 1980 - Eagle Claims Completed

| | | | |
|----|----------------------|----------------|-------------|
| 21 | Line KM - IP Survey | @ \$385.00/KM | \$ 8,085.00 |
| 1 | Day Detail IP | @ \$540.00/day | 540.00 |
| 3 | Days Standby | @ \$205.00/day | 615.00 |
| 21 | Line KM - VLF Survey | @ \$205.00/KM | 4,305.00 |
| 21 | Line KM - Mag Survey | @ \$100.00/KM | 2,100.00 |
| | | | <hr/> |
| | | | \$15,645.00 |
| | | | <hr/> |

PHOENIX GEOPHYSICS LIMITED

Philip G. Hallof
Philip G. Hallof, Ph.D., P. Eng.
Geophysicist

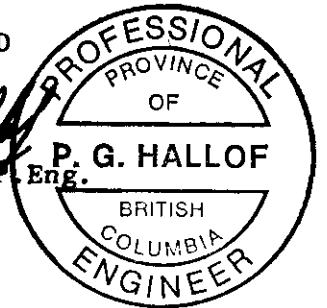

Expiry Date: February 25, 1981

Dated: January 7, 1981

CERTIFICATE

I, Paul A. Cartwright, of the City of Vancouver, Province of British Columbia, do hereby certify that:

1. I am a geophysicist residing at 4238 West 11th Avenue, Vancouver, B.C.
2. I am a graduate of the University of British Columbia, B.C. with a B.Sc. Degree.
3. I am a member of the Society of Exploration Geophysicists.
4. I have been practising my profession about 10 years.
5. I have no direct or indirect interest, nor do I expect to receive any interest directly or indirectly, in the property or securities of Cordilleran Engineering Ltd., or any affiliate.
6. The statements made in this report are based on a study of published geological literature and unpublished private reports.
7. Permission is granted to use in whole or in part for assessment and qualification requirements but not for advertising purposes.

Dated at Vancouver

This 7th day of January, 1981



Paul A. Cartwright, B.Sc.

CERTIFICATE

I, Philip George Hallof, of the City of Toronto, Province of Ontario, do hereby certify that:

1. I am a geophysicist residing at Suite 3505, 2045 Lake Shore Blvd.W., Toronto, Ontario.
2. I am a graduate of the Massachusetts Institute of Technology with a B.Sc. Degree (1952) in Geology and Geophysics, and a Ph.D. Degree (1957) in Geophysics.
3. I am a member of the Society of Exploration Geophysicists and the European Association of the Exploration Geophysicists.
4. I am a Professional Geophysicist, registered in the Province of Ontario, the Province of British Columbia and the State of Arizona.
5. I have no direct or indirect interest, nor do I expect to receive any interest directly or indirectly, in the property or securities of Cordilleran Engineering Ltd., or any affiliate.
6. The statements made in this report are based on a study of published geological literature and unpublished private reports.
7. Permission is granted to use in whole or in part for assessment and qualification requirements but not for advertising purposes.

Dated at Toronto

This 7th day of January, 1981

Philip G. Hallof, Ph.D.



Expiry Date: February 25, 1981

PHOENIX GEOPHYSICS LIMITED

COMBINED GEOPHYSICAL SURVEYS

PLAN MAP

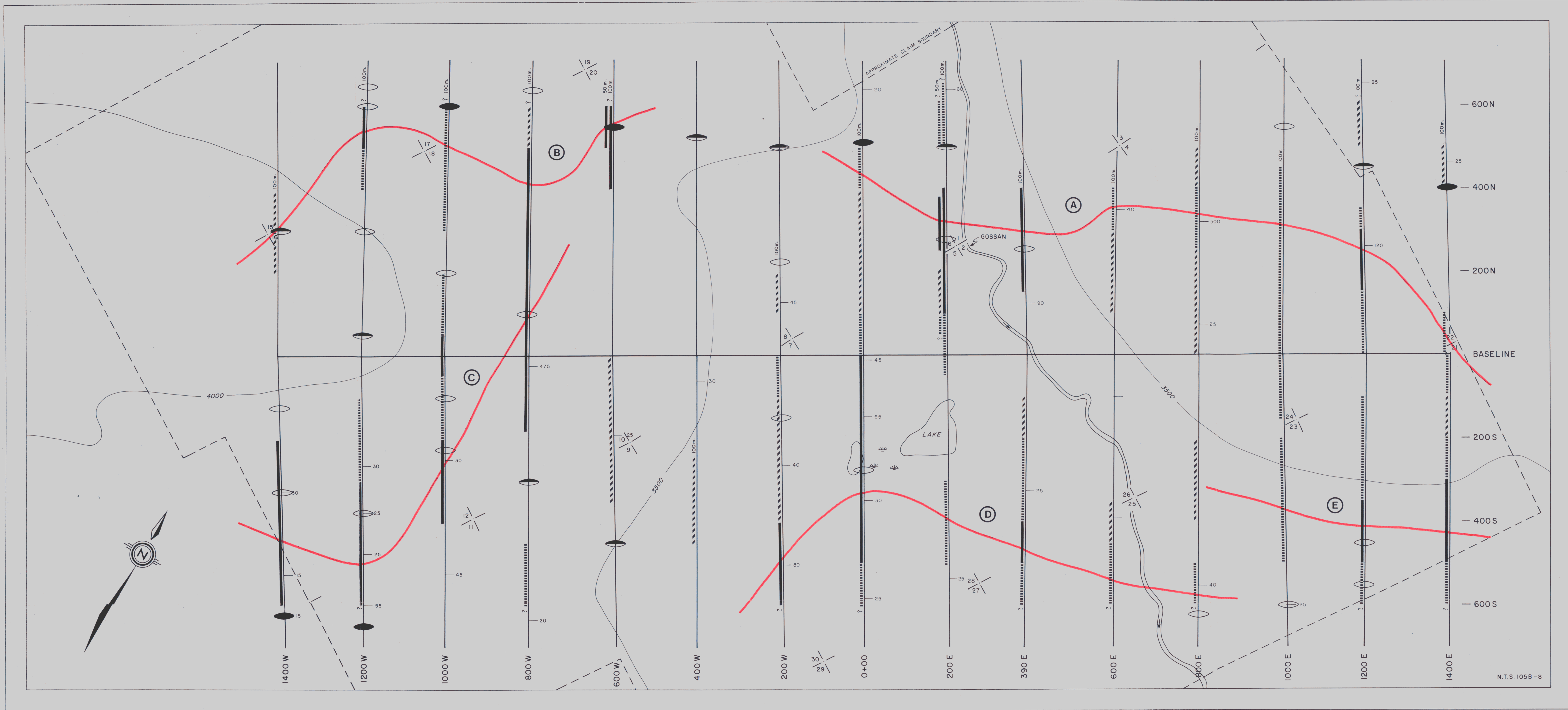

N.T.S. 105B-8

CORDILLERAN ENGINEERING LTD.

EAGLE CLAIM GROUP, WATSON M.D.

YUKON TERRITORY



- (I.P.)
SURFACE PROJECTION
OF ANOMALOUS ZONE
DEFINITE ———
PROBABLE - - - - -
POSSIBLE - - - - -
NUMBER AT END OF ANOMALIES
INDICATE SPREAD USED.
- (VLF-EM)
ANOMALY CLASSIFICATION
DEFINITE ●
PROBABLE ○
POSSIBLE ○
CUTLER VLF TRANSMITTER

- CLAIM POST LOCATION
WITH N2 1 POST.
- PEAK AMPLITUDE
IN GAMMAS

NOTE - ELEVATIONS ARE APPROXIMATE (Feet)

— AXIS OF ANOMALOUS I.P. ZONE

PROFESSIONAL
ENGINEER
DRAWN BY: R.C.N.
DATE: DEC 1980
APPROVED BY: P. J. HALLOF
DATE: 1/1/81
EXPIRY DATE: 1/1/81

CORDILLERAN ENGINEERING LTD.

EAGLE CLAIM GROUP, WATSON LAKE M.D.

YUKON TERRITORY

LINE NO. - 1400W

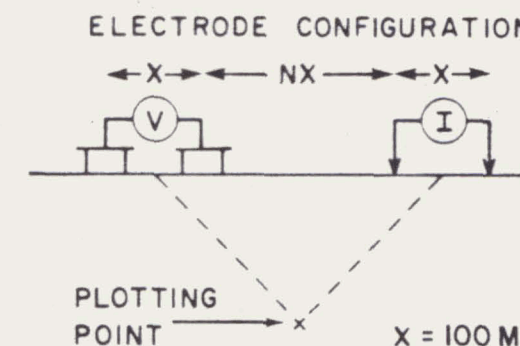

SURFACE PROJECTION OF ANOMALOUS ZONE

DEFINITE

PROBABLE

POSSIBLE

FREQUENCIES 0.3 - 5.0 HZ.

DATE SURVEYED 15 JUNE 1980

APPROVED

DATE 17/81

Expiry Date: February 25, 1981

NOTE - CONTOURS AT LOGARITHMIC INTERVALS 1, -1.5, -2, -3, -5, -7.5, -10

PHOENIX GEOPHYSICS LIMITED

INDUCED POLARIZATION AND RESISTIVITY SURVEY

| EAGLE CLAIMS LINE-1400W | | | | | | | | | | | | X=100M | | RHO (OHM-M) | |
|-------------------------|------|------|------|------|------|------|------|------|-----|------|-----|--------|-----|-------------|--|
| DIPOLE NUMBER | 2 | 3 | 4 | 5 | 6 | 7 | 8 | 9 | 10 | 11 | 12 | | | | |
| COORDINATE | 500S | 300S | 100S | 100N | 300N | 500N | | | | | | | | | |
| INTERPRETATION | | | | | | | | | | | | | | | |
| N=1 | 343 | 254 | 497 | 308 | 855 | 752 | 1155 | 1454 | 492 | 732 | 779 | 810 | N=1 | | |
| N=2 | 187 | 428 | 432 | 495 | 1054 | 840 | 1107 | 859 | 750 | 1093 | 667 | | N=2 | | |
| N=3 | 475 | 365 | 802 | 643 | 1040 | 721 | 658 | 1108 | 985 | 1053 | | | N=3 | | |
| N=4 | 434 | 654 | 1048 | 570 | 864 | 438 | 839 | 1394 | 913 | | | | N=4 | | |
| N=5 | 787 | 825 | 863 | 459 | 526 | 533 | 1036 | 1228 | | | | | N=5 | | |

| EAGLE CLAIMS LINE-1400W | | | | | | | | | | | | X=100M | | PFE | |
|-------------------------|------|------|------|------|------|------|-----|-----|-----|-----|-----|--------|-----|-----|--|
| DIPOLE NUMBER | 2 | 3 | 4 | 5 | 6 | 7 | 8 | 9 | 10 | 11 | 12 | | | | |
| COORDINATE | 500S | 300S | 100S | 100N | 300N | 500N | | | | | | | | | |
| INTERPRETATION | | | | | | | | | | | | | | | |
| N=1 | 9.4 | 8.5 | 6.3 | 4.3 | 2.5 | 1.6 | 1.6 | 1.0 | 1.8 | 2.0 | 1.3 | 1.6 | N=1 | | |
| N=2 | 9.1 | 7.5 | 5.6 | 5.1 | 2.6 | 1.8 | 2.6 | 2.6 | 3.0 | 3.3 | 2.1 | | N=2 | | |
| N=3 | 6.6 | 6.6 | 5.6 | 5.1 | 3.0 | 3.0 | 3.5 | 3.4 | 3.8 | 3.5 | | | N=3 | | |
| N=4 | 6.1 | 6.6 | 5.1 | 5.6 | 4.1 | 4.0 | 4.1 | 4.3 | 4.2 | | | | N=4 | | |
| N=5 | 6.1 | 5.6 | 5.5 | 7.0 | 4.8 | 4.1 | 4.3 | 3.6 | | | | | N=5 | | |

| EAGLE CLAIMS LINE-1400W | | | | | | | | | | | | X=100M | | METAL FACTOR | |
|-------------------------|------|------|------|------|------|------|-----|-----|-----|-----|-----|--------|-----|--------------|--|
| DIPOLE NUMBER | 2 | 3 | 4 | 5 | 6 | 7 | 8 | 9 | 10 | 11 | 12 | | | | |
| COORDINATE | 500S | 300S | 100S | 100N | 300N | 500N | | | | | | | | | |
| INTERPRETATION | | | | | | | | | | | | | | | |
| N=1 | 27 | 33 | 13 | 14 | 2.9 | 2.1 | 1.3 | .6 | 3.6 | 2.7 | 1.6 | 1.9 | N=1 | | |
| N=2 | 49 | 18 | 13 | 10 | 2.4 | 2.1 | 2.3 | 3.0 | 4.0 | 3.0 | 3.1 | | N=2 | | |
| N=3 | 14 | 18 | 6.9 | 7.9 | 2.8 | 4.1 | 5.3 | 3.0 | 3.8 | 3.3 | | | N=3 | | |
| N=4 | 14 | 10 | 4.8 | 9.8 | 4.7 | 9.1 | 4.8 | 3.0 | 4.5 | | | | N=4 | | |
| N=5 | 7.7 | 6.7 | 6.3 | 15 | 9.1 | 7.6 | 4.1 | 2.9 | | | | | N=5 | | |

CORDILLERAN ENGINEERING LTD.

EAGLE CLAIM GROUP, WATSON LAKE M.D.

YUKON TERRITORY

LINE NO. - 1200W

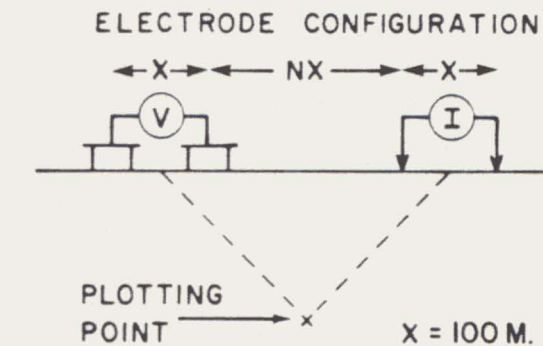

SURFACE PROJECTION OF ANOMALOUS ZONE

DEFINITE **—————**
 PROBABLE **.....**
 POSSIBLE **///////**

FREQUENCIES 0.3-5.0 HZ.

DATE SURVEYED JUNE 1980

APPROVED *Philip S. Hallop*

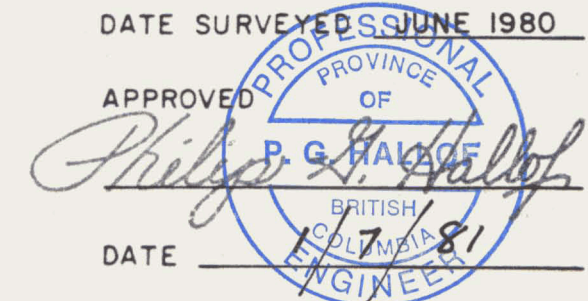

NOTE - CONTOURS AT LOGARITHMIC INTERVALS 1, -1.5, -2, -3, -5, -7.5, -10

DATE 1/7/81

Expiry Date: February 25, 1981

PHOENIX GEOPHYSICS LIMITED

INDUCED POLARIZATION AND RESISTIVITY SURVEY

| EAGLE CLAIMS LINE-1200W | | | | | | | | | | | | X=100M | | RHO (OHM-M) | |
|-------------------------|------|------|------|------|------|------|------|------|------|------|------|--------|-----|-------------|--|
| DIPOLE NUMBER | | 2 | 3 | 4 | 5 | 6 | 7 | 8 | 9 | 10 | 11 | 12 | | | |
| COORDINATE | | 500S | 300S | 100S | 100N | 300N | 500N | | | | | | | | |
| INTERPRETATION | | | | | | | | | | | | | | | |
| N=1 | 1217 | 669 | 633 | 686 | 415 | 490 | 694 | 720 | 1149 | 1668 | 1014 | 712 | N=1 | | |
| N=2 | 323 | 541 | 491 | 501 | 429 | 763 | 961 | 804 | 1875 | 1114 | 562 | N=2 | | | |
| N=3 | 301 | 559 | 593 | 490 | 665 | 950 | 986 | 1425 | 1377 | 654 | N=3 | | | | |
| N=4 | 351 | 730 | 600 | 698 | 831 | 913 | 1725 | 1076 | 791 | N=4 | | | | | |
| N=5 | 456 | 702 | 861 | 1162 | 742 | 1523 | 1215 | 643 | N=5 | | | | | | |

| EAGLE CLAIMS LINE-1200W | | | | | | | | | | | | X=100M | | PFE | |
|-------------------------|-----|------|------|------|------|------|------|-----|-----|-----|-----|--------|-----|-----|--|
| DIPOLE NUMBER | | 2 | 3 | 4 | 5 | 6 | 7 | 8 | 9 | 10 | 11 | 12 | | | |
| COORDINATE | | 500S | 300S | 100S | 100N | 300N | 500N | | | | | | | | |
| INTERPRETATION | | | | | | | | | | | | | | | |
| N=1 | 8.0 | 5.3 | 5.7 | 4.8 | 3.5 | 2.0 | 2.2 | 2.8 | 2.7 | 4.4 | 8.8 | 7.5 | N=1 | | |
| N=2 | 8.8 | 8.4 | 7.5 | 6.5 | 3.8 | 3.1 | 3.2 | 2.3 | 6.4 | 6.7 | 4.3 | N=2 | | | |
| N=3 | 10 | 7.5 | 5.2 | 6.3 | 5.2 | 3.6 | 2.9 | 4.0 | 6.2 | 3.5 | N=3 | | | | |
| N=4 | 8.6 | 6.2 | 5.3 | 6.8 | 5.7 | 3.6 | 5.5 | 3.8 | 3.3 | N=4 | | | | | |
| N=5 | 7.4 | 5.7 | 6.0 | 6.7 | 5.8 | 5.6 | 4.0 | 1.9 | N=5 | | | | | | |

| EAGLE CLAIMS LINE-1200W | | | | | | | | | | | | X=100M | | METAL FACTOR | |
|-------------------------|-----|------|------|------|------|------|------|-----|-----|-----|-----|--------|-----|--------------|--|
| DIPOLE NUMBER | | 2 | 3 | 4 | 5 | 6 | 7 | 8 | 9 | 10 | 11 | 12 | | | |
| COORDINATE | | 500S | 300S | 100S | 100N | 300N | 500N | | | | | | | | |
| INTERPRETATION | | | | | | | | | | | | | | | |
| N=1 | 6.5 | 7.9 | 9.0 | 6.9 | 8.4 | 4.0 | 3.1 | 3.8 | 2.3 | 2.6 | 8.6 | 11 | N=1 | | |
| N=2 | 27 | 16 | 15 | 13 | 8.8 | 4.0 | 3.3 | 2.8 | 3.4 | 6.0 | 7.6 | N=2 | | | |
| N=3 | 34 | 13 | 8.7 | 13 | 7.8 | 3.7 | 2.9 | 2.8 | 4.5 | 5.3 | N=3 | | | | |
| N=4 | 24 | 8.4 | 8.8 | 9.7 | 6.8 | 3.9 | 3.1 | 3.5 | 4.1 | N=4 | | | | | |
| N=5 | 16 | 8.1 | 6.9 | 5.7 | 7.8 | 3.6 | 3.2 | 2.9 | N=5 | | | | | | |

CORDILLERAN ENGINEERING LTD.

EAGLE CLAIM GROUP, WATSON LAKE M.D.

YUKON TERRITORY

LINE NO. - 1000W

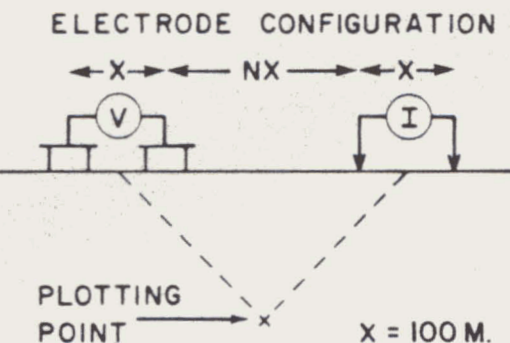

SURFACE PROJECTION OF ANOMALOUS ZONE

DEFINITE

PROBABLE

POSSIBLE

FREQUENCIES 0.3-5.0 HZ.

DATE SURVEYED JUNE 1980

APPROVED

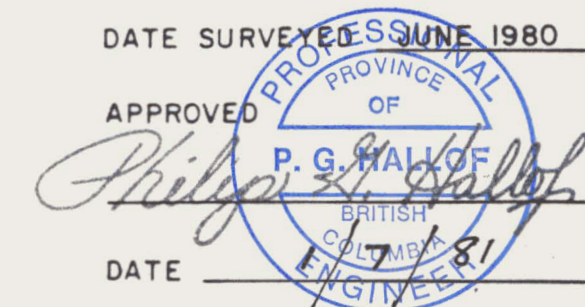

NOTE - CONTOURS AT LOGARITHMIC INTERVALS 1, -1.5, -2, -3, -5, -7.5, -10

DATE

Expiry Date: February 25, 1981

PHOENIX GEOPHYSICS LIMITED

INDUCED POLARIZATION AND RESISTIVITY SURVEY

| EAGLE CLAIMS LINE-1000W | | | | | | | | | | | | X=100M | | RHO (OHM-M) | |
|-------------------------|------|------|------|------|------|------|-----|------|------|-----|------|--------|-----|-------------|--|
| DIPOLE NUMBER | 2 | 3 | 4 | 5 | 6 | 7 | 8 | 9 | 10 | 11 | 12 | | | | |
| COORDINATE | 500S | 300S | 100S | 100N | 300N | 500N | | | | | | | | | |
| INTERPRETATION | | | | | | | | | | | | | | | |
| N=1 | 1900 | 1801 | 516 | 570 | 518 | 422 | 475 | 434 | 1002 | 889 | 1293 | 1115 | N=1 | | |
| N=2 | 1260 | 595 | 459 | 553 | 510 | 446 | 337 | 1071 | 713 | 873 | 997 | N=2 | | | |
| N=3 | 536 | 575 | 475 | 610 | 514 | 380 | 825 | 977 | 800 | 603 | N=3 | | | | |
| N=4 | 550 | 610 | 624 | 617 | 435 | 817 | 818 | 1004 | 558 | N=4 | | | | | |
| N=5 | 636 | 787 | 605 | 506 | 942 | 816 | 797 | 718 | N=5 | | | | | | |

| EAGLE CLAIMS LINE-1000W | | | | | | | | | | | | X=100M | | PFE | |
|-------------------------|------|------|------|------|------|------|-----|-----|-----|-----|-----|--------|-----|-----|--|
| DIPOLE NUMBER | 2 | 3 | 4 | 5 | 6 | 7 | 8 | 9 | 10 | 11 | 12 | | | | |
| COORDINATE | 500S | 300S | 100S | 100N | 300N | 500N | | | | | | | | | |
| INTERPRETATION | | | | | | | | | | | | | | | |
| N=1 | 4.1 | 2.4 | 5.4 | 5.0 | 3.5 | 4.0 | 4.5 | 3.6 | 2.5 | 5.5 | 4.6 | 5.8 | N=1 | | |
| N=2 | 5.0 | 6.3 | 6.2 | 7.2 | 5.0 | 5.7 | 2.4 | 4.0 | 5.1 | 3.5 | 5.2 | N=2 | | | |
| N=3 | 7.5 | 6.3 | 6.5 | 6.8 | 5.8 | 5.2 | 4.7 | 5.5 | 3.0 | 3.6 | N=3 | | | | |
| N=4 | 7.3 | 6.4 | 5.5 | 6.9 | 5.3 | 5.3 | 5.9 | 2.6 | 3.6 | N=4 | | | | | |
| N=5 | 7.0 | 5.6 | 6.1 | 12 | 5.3 | 6.3 | 3.1 | 3.1 | N=5 | | | | | | |

| EAGLE CLAIMS LINE-1000W | | | | | | | | | | | | X=100M | | METAL FACTOR | |
|-------------------------|------|------|------|------|------|------|-----|-----|-----|-----|-----|--------|-----|--------------|--|
| DIPOLE NUMBER | 2 | 3 | 4 | 5 | 6 | 7 | 8 | 9 | 10 | 11 | 12 | | | | |
| COORDINATE | 500S | 300S | 100S | 100N | 300N | 500N | | | | | | | | | |
| INTERPRETATION | | | | | | | | | | | | | | | |
| N=1 | 2.1 | 1.3 | 10 | 8.7 | 6.7 | 9.4 | 9.4 | 8.2 | 2.4 | 6.1 | 3.5 | 5.2 | N=1 | | |
| N=2 | 3.9 | 11 | 13 | 13 | 9.7 | 13 | 7.1 | 3.7 | 7.1 | 4.0 | 5.2 | N=2 | | | |
| N=3 | 14 | 11 | 14 | 11 | 11 | 14 | 5.6 | 5.6 | 3.7 | 5.9 | N=3 | | | | |
| N=4 | 13 | 10 | 8.8 | 11 | 12 | 6.4 | 7.2 | 2.5 | 6.4 | N=4 | | | | | |
| N=5 | 11 | 7.1 | 10 | 6.3 | 5.6 | 7.7 | 3.8 | 4.3 | N=5 | | | | | | |

CORDILLERAN ENGINEERING LTD.

EAGLE CLAIM GROUP, WATSON LAKE M.D.

YUKON TERRITORY

LINE NO. - 800W

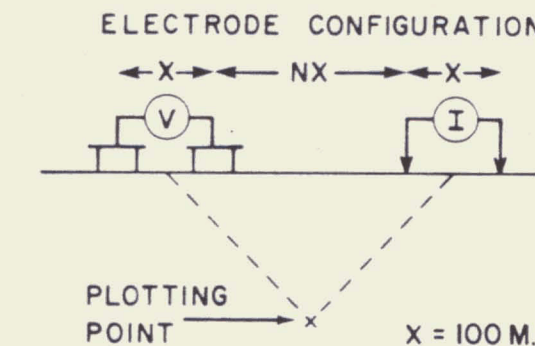

SURFACE PROJECTION OF ANOMALOUS ZONE

DEFINITE **—————**
 PROBABLE **.....**
 POSSIBLE **///////**

FREQUENCIES 0.3-5.0 HZ.

DATE SURVEYED JUNE 1980

APPROVED

P. G. HALLOP
 PROFESSIONAL ENGINEER
 PROVINCE OF BRITISH COLUMBIA
 1/7/81

NOTE - CONTOURS AT LOGARITHMIC INTERVALS
 1, -1.5, -2, -3, -5, -7.5, -10

DATE

Expiry Date: February 25, 1981

PHOENIX GEOPHYSICS LIMITED

INDUCED POLARIZATION AND RESISTIVITY SURVEY

| EAGLE CLAIMS LINE-800W | | | | | | | | | | | | X=100M | | RHO (OHM-M) | |
|------------------------|------|------|------|------|------|------|-----|-----|-----|-----|-----|--------|-----|-------------|--|
| DIPOLE NUMBER | 2 | 3 | 4 | 5 | 6 | 7 | 8 | 9 | 10 | 11 | 12 | | | | |
| COORDINATE | 500S | 300S | 100S | 100N | 300N | 500N | | | | | | | | | |
| INTERPRETATION | | | | | | | | | | | | | | | |
| N=1 | 983 | 894 | 862 | 1108 | 929 | 913 | 641 | 532 | 372 | 440 | 496 | 444 | N=1 | | |
| N=2 | 1312 | 973 | 1235 | 980 | 535 | 645 | 641 | 502 | 606 | 490 | 425 | | N=2 | | |
| N=3 | 1132 | 1117 | 950 | 627 | 401 | 670 | 625 | 817 | 585 | 484 | | | N=3 | | |
| N=4 | 1229 | 836 | 665 | 457 | 409 | 676 | 971 | 741 | 522 | | | | N=4 | | |
| N=5 | 958 | 597 | 484 | 453 | 460 | 1041 | 815 | 693 | | | | | N=5 | | |

| EAGLE CLAIMS LINE-800W | | | | | | | | | | | | X=100M | | PFE | |
|------------------------|------|------|------|------|------|------|-----|-----|-----|-----|-----|--------|-----|-----|--|
| DIPOLE NUMBER | 2 | 3 | 4 | 5 | 6 | 7 | 8 | 9 | 10 | 11 | 12 | | | | |
| COORDINATE | 500S | 300S | 100S | 100N | 300N | 500N | | | | | | | | | |
| INTERPRETATION | | | | | | | | | | | | | | | |
| N=1 | 6.9 | 3.7 | 2.7 | 2.5 | 3.5 | 3.6 | 5.1 | 4.6 | 5.8 | 4.6 | 4.3 | 2.3 | N=1 | | |
| N=2 | 4.9 | 3.5 | 4.0 | 4.8 | 4.6 | 5.5 | 5.5 | 4.5 | 3.5 | 4.6 | 3.6 | | N=2 | | |
| N=3 | 4.7 | 4.4 | 5.8 | 5.5 | 6.2 | 5.4 | 5.1 | 2.6 | 4.2 | 3.8 | | | N=3 | | |
| N=4 | 6.0 | 6.1 | 6.1 | 5.7 | 5.2 | 4.9 | 2.6 | 3.0 | 3.2 | | | | N=4 | | |
| N=5 | 7.2 | 5.6 | 5.5 | 5.0 | 5.0 | 3.1 | 4.0 | 2.5 | | | | | N=5 | | |

| EAGLE CLAIMS LINE-800W | | | | | | | | | | | | X=100M | | METAL FACTOR | |
|------------------------|------|------|------|------|------|------|-----|-----|-----|-----|-----|--------|-----|--------------|--|
| DIPOLE NUMBER | 2 | 3 | 4 | 5 | 6 | 7 | 8 | 9 | 10 | 11 | 12 | | | | |
| COORDINATE | 500S | 300S | 100S | 100N | 300N | 500N | | | | | | | | | |
| INTERPRETATION | | | | | | | | | | | | | | | |
| N=1 | 7.0 | 4.1 | 3.1 | 2.2 | 3.7 | 3.9 | 7.9 | 8.6 | 16 | 10 | 8.6 | 5.1 | N=1 | | |
| N=2 | 3.7 | 3.5 | 3.2 | 4.8 | 8.5 | 8.5 | 8.5 | 8.9 | 5.7 | 9.3 | 8.4 | | N=2 | | |
| N=3 | 4.1 | 3.9 | 6.1 | 8.7 | 15 | 8.0 | 8.1 | 3.1 | 7.1 | 7.8 | | | N=3 | | |
| N=4 | 4.8 | 7.2 | 9.1 | 12 | 13 | 7.2 | 2.6 | 4.0 | 6.1 | | | | N=4 | | |
| N=5 | 7.5 | 9.3 | 11 | 11 | 11 | 2.9 | 4.9 | 3.6 | | | | | N=5 | | |

CORDILLERAN ENGINEERING LTD.

EAGLE CLAIM GROUP, WATSON LAKE M.D.

YUKON TERRITORY

LINE NO. - 600W

ELECTRODE CONFIGURATION

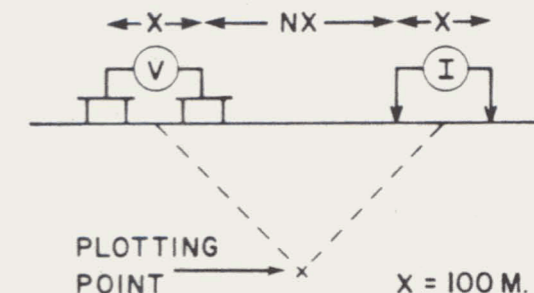

SURFACE PROJECTION OF ANOMALOUS ZONE

DEFINITE
 PROBABLE
 POSSIBLE

FREQUENCIES 0.3-5.0 HZ.

DATE SURVEYED JUNE 1980

APPROVED

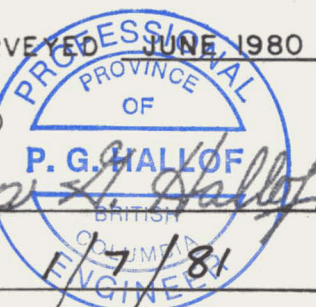

NOTE - CONTOURS AT LOGARITHMIC INTERVALS 1, -1.5, -2, -3, -5, -7.5, -10

DATE

Expiry Date: February 25, 1981

PHOENIX GEOPHYSICS LIMITED

INDUCED POLARIZATION AND RESISTIVITY SURVEY

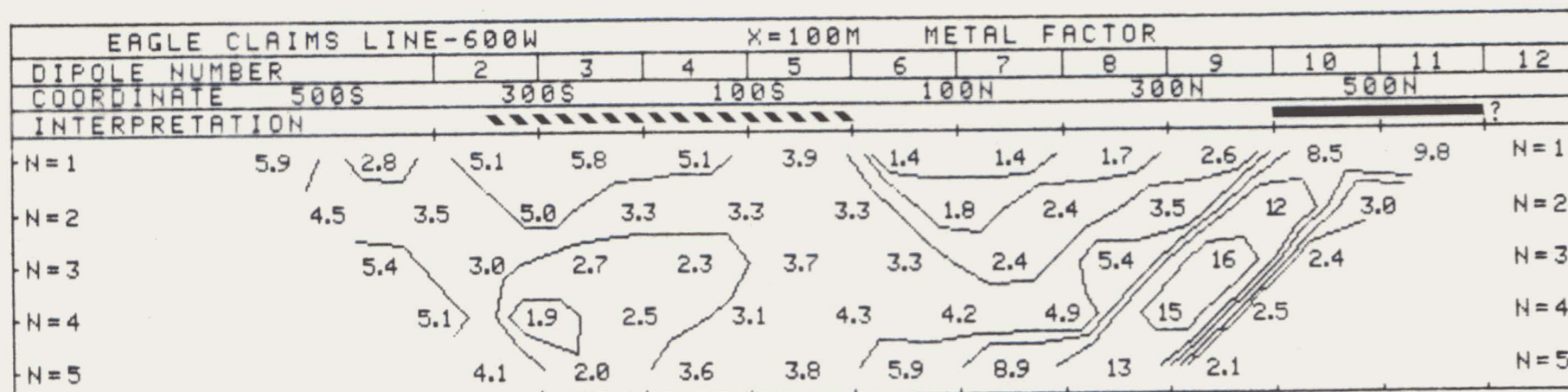
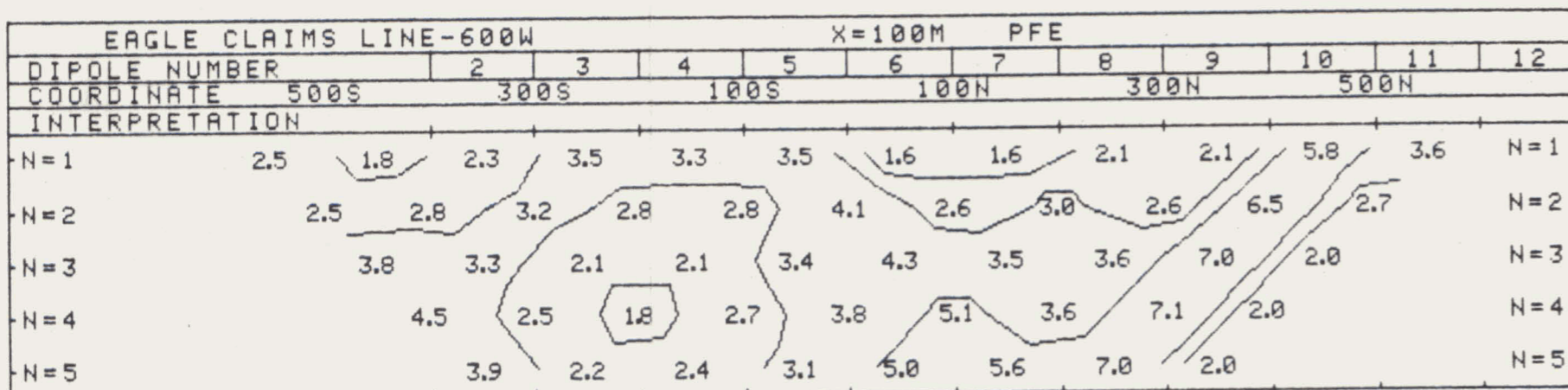
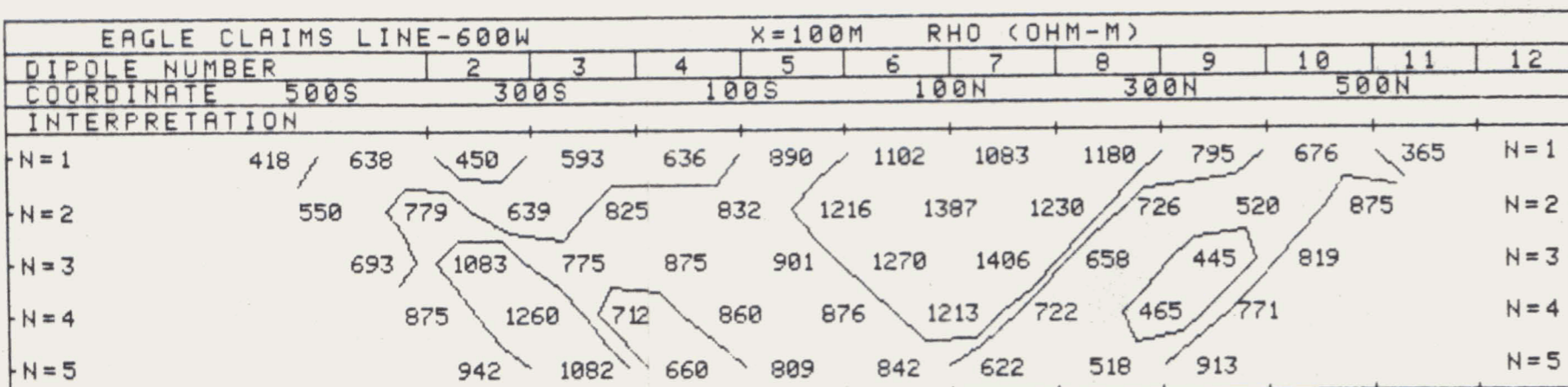

CORDILLERAN ENGINEERING LTD.

EAGLE CLAIM GROUP, WATSON LAKE M.D.

YUKON TERRITORY

LINE NO. - 600W

ELECTRODE CONFIGURATION

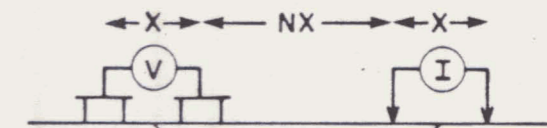

PLOTTING POINT X = 50M.

SURFACE PROJECTION OF ANOMALOUS ZONE

DEFINITE
 PROBABLE
 POSSIBLE

FREQUENCIES 0.3-5.0 HZ.

DATE SURVEYED JUNE 1980

APPROVED

Philip S. Hall
 PROFESSIONAL ENGINEER
 PROVINCE OF BRITISH COLUMBIA
 DATE 1/7/81

NOTE - CONTOURS AT LOGARITHMIC INTERVALS 1, -1.5, -2, -3, -5, -7.5, -10

Expiry Date: February 25, 1981

PHOENIX GEOPHYSICS LIMITED

INDUCED POLARIZATION AND RESISTIVITY SURVEY

| EAGLE CLAIMS LINE-600W | | | | | | | | | | | X=50M | RHO (OHM-M) |
|------------------------|------|------|------|------|------|------|------|-----|-----|-----|-------|-------------|
| DIPOLE NUMBER | 1 | 2 | 3 | 4 | 5 | 6 | 7 | 8 | 9 | 10 | | |
| COORDINATE | 150N | 250N | 350N | 450N | 550N | 650N | | | | | | |
| INTERPRETATION | | | | | | | | | | | | |
| N=1 | | 597 | 779 | 741 | 1098 | 1045 | 781 | 413 | 220 | 228 | 268 | N=1 |
| N=2 | | 991 | 849 | 1087 | 1093 | 825 | 1106 | 703 | 230 | 308 | 210 | N=2 |
| N=3 | | 1138 | 1202 | 997 | 1335 | 726 | 886 | 798 | 495 | 380 | 359 | N=3 |
| N=4 | | 1480 | 1179 | 1216 | 1108 | 798 | 712 | 601 | 560 | 791 | 426 | N=4 |
| N=5 | 1261 | 1516 | 1138 | 1289 | 610 | 707 | 484 | 478 | 874 | 877 | | N=5 |

| EAGLE CLAIMS LINE-600W | | | | | | | | | | | X=50M | PFE |
|------------------------|------|------|------|------|------|------|-----|-----|-----|-----|-------|-----|
| DIPOLE NUMBER | 1 | 2 | 3 | 4 | 5 | 6 | 7 | 8 | 9 | 10 | | |
| COORDINATE | 150N | 250N | 350N | 450N | 550N | 650N | | | | | | |
| INTERPRETATION | | | | | | | | | | | | |
| N=1 | | 1.0 | 1.2 | 1.4 | 1.8 | 3.0 | 1.6 | 3.4 | 11 | 10 | 3.0 | N=1 |
| N=2 | | 1.0 | 1.4 | 1.8 | 2.4 | 2.0 | 2.3 | 4.2 | 9.5 | 4.5 | 7.5 | N=2 |
| N=3 | | 1.5 | 1.4 | 1.5 | 2.3 | 2.5 | 2.1 | 4.8 | 9.0 | 3.5 | 2.8 | N=3 |
| N=4 | | 2.5 | 1.6 | 2.3 | 2.5 | 2.5 | 2.6 | 5.3 | 8.7 | 3.1 | 2.5 | N=4 |
| N=5 | 2.5 | 1.5 | 2.8 | 3.0 | 2.9 | 3.1 | 6.0 | 7.8 | 3.0 | 2.2 | | N=5 |

| EAGLE CLAIMS LINE-600W | | | | | | | | | | | X=50M | METAL FACTOR |
|------------------------|------|------|------|------|------|------|-----|-----|-----|-----|-------|--------------|
| DIPOLE NUMBER | 1 | 2 | 3 | 4 | 5 | 6 | 7 | 8 | 9 | 10 | | |
| COORDINATE | 150N | 250N | 350N | 450N | 550N | 650N | | | | | | |
| INTERPRETATION | | | | | | | | | | | | |
| N=1 | | 1.6 | 1.5 | 1.8 | 1.6 | 2.0 | 2.0 | 8.2 | 48 | 45 | 11 | N=1 |
| N=2 | | 1.0 | 1.6 | 1.6 | 2.1 | 2.4 | 2.0 | 5.9 | 41 | 15 | 36 | N=2 |
| N=3 | | 1.3 | 1.1 | 1.5 | 1.7 | 3.4 | 2.3 | 6.0 | 18 | 9.2 | 7.7 | N=3 |
| N=4 | | 1.6 | 1.3 | 1.8 | 2.2 | 3.1 | 3.6 | 8.8 | 16 | 3.9 | 5.8 | N=4 |
| N=5 | 1.9 | .9 | 2.4 | 2.3 | 4.7 | 4.3 | 12 | 16 | 3.4 | 2.5 | | N=5 |

CORDILLERAN ENGINEERING LTD.

EAGLE CLAIM GROUP, WATSON LAKE M.D.

YUKON TERRITORY

LINE NO. - 400W

ELECTRODE CONFIGURATION

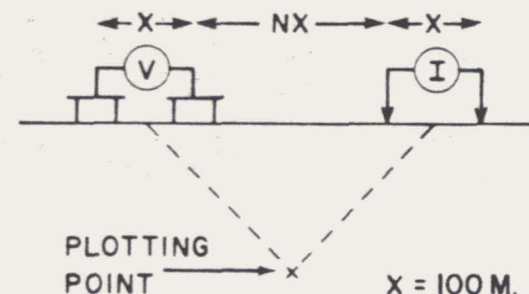

SURFACE PROJECTION OF ANOMALOUS ZONE

DEFINITE **————**
 PROBABLE **.....**
 POSSIBLE **//////**

FREQUENCIES 0.3-5.0 HZ.

DATE SURVEYED JUNE 1980

APPROVED



NOTE - CONTOURS AT LOGARITHMIC INTERVALS
 1, -1.5, -2, -3, -5, -7.5, -10

DATE

Expiry Date: February 25, 1981

PHOENIX GEOPHYSICS LIMITED

INDUCED POLARIZATION AND RESISTIVITY SURVEY

| EAGLE CLAIMS LINE-400W | | | | | | | | | | | | X=100M | | RHO (OHM-M) | |
|------------------------|------|------|------|------|------|------|-----|-----|-----|-----|-----|--------|-----|-------------|--|
| DIPOLE NUMBER | 2 | 3 | 4 | 5 | 6 | 7 | 8 | 9 | 10 | 11 | 12 | | | | |
| COORDINATE | 500S | 300S | 100S | 100N | 300N | 500N | | | | | | | | | |
| INTERPRETATION | | | | | | | | | | | | | | | |
| N=1 | 720 | 545 | 625 | 544 | 644 | 452 | 683 | 563 | 684 | 660 | 532 | 626 | N=1 | | |
| N=2 | 807 | 511 | 587 | 676 | 571 | 548 | 814 | 706 | 750 | 580 | 708 | N=2 | | | |
| N=3 | 773 | 526 | 753 | 615 | 651 | 630 | 961 | 734 | 646 | 819 | N=3 | | | | |
| N=4 | 696 | 695 | 640 | 681 | 723 | 708 | 973 | 604 | 893 | N=4 | | | | | |
| N=5 | 1006 | 594 | 660 | 717 | 742 | 690 | 804 | 843 | N=5 | | | | | | |

| EAGLE CLAIMS LINE-400W | | | | | | | | | | | | X=100M | | PFE | |
|------------------------|------|------|------|------|------|------|-----|-----|-----|-----|-----|--------|-----|-----|--|
| DIPOLE NUMBER | 2 | 3 | 4 | 5 | 6 | 7 | 8 | 9 | 10 | 11 | 12 | | | | |
| COORDINATE | 500S | 300S | 100S | 100N | 300N | 500N | | | | | | | | | |
| INTERPRETATION | | | | | | | | | | | | | | | |
| N=1 | 2.3 | 2.2 | 2.0 | 1.8 | 2.0 | 2.3 | 2.0 | 2.3 | 2.2 | 2.6 | 1.7 | 1.8 | N=1 | | |
| N=2 | 2.8 | 2.0 | 2.3 | 2.5 | 2.7 | 2.2 | 2.1 | 2.3 | 2.7 | 2.0 | 2.4 | N=2 | | | |
| N=3 | 2.6 | 2.2 | 2.8 | 2.8 | 2.3 | 2.8 | 2.5 | 2.8 | 2.0 | 2.9 | N=3 | | | | |
| N=4 | 3.3 | 3.1 | 3.0 | 2.8 | 2.6 | 2.5 | 2.6 | 2.8 | 2.8 | N=4 | | | | | |
| N=5 | 4.1 | 3.3 | 2.6 | 3.3 | 2.6 | 2.9 | 2.1 | 3.3 | N=5 | | | | | | |

| EAGLE CLAIMS LINE-400W | | | | | | | | | | | | X=100M | | METAL FACTOR | |
|------------------------|------|------|------|------|------|------|-----|-----|-----|-----|-----|--------|-----|--------------|--|
| DIPOLE NUMBER | 2 | 3 | 4 | 5 | 6 | 7 | 8 | 9 | 10 | 11 | 12 | | | | |
| COORDINATE | 500S | 300S | 100S | 100N | 300N | 500N | | | | | | | | | |
| INTERPRETATION | | | | | | | | | | | | | | | |
| N=1 | 3.1 | 4.0 | 3.1 | 3.3 | 3.1 | 5.0 | 2.9 | 4.0 | 3.2 | 3.9 | 3.1 | 2.8 | N=1 | | |
| N=2 | 3.4 | 3.9 | 3.9 | 3.6 | 4.7 | 4.0 | 2.5 | 3.2 | 3.6 | 3.4 | 3.3 | N=2 | | | |
| N=3 | 3.3 | 4.1 | 3.7 | 4.5 | 3.5 | 4.4 | 2.5 | 3.8 | 3.0 | 3.5 | N=3 | | | | |
| N=4 | 4.7 | 4.4 | 4.6 | 4.1 | 3.5 | 3.5 | 2.6 | 4.6 | 3.1 | N=4 | | | | | |
| N=5 | 4.0 | 5.5 | 3.9 | 4.6 | 3.5 | 4.2 | 2.6 | 3.9 | N=5 | | | | | | |

CORDILLERAN ENGINEERING LTD.

EAGLE CLAIM GROUP, WATSON LAKE M.D.

YUKON TERRITORY

LINE NO. - 200W

ELECTRODE CONFIGURATION

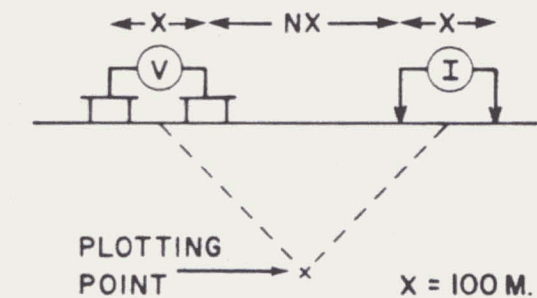

PLOTTING POINT

X = 100 M.

SURFACE PROJECTION OF ANOMALOUS ZONE

DEFINITE
 PROBABLE
 POSSIBLE

FREQUENCIES 0.3 - 5.0 HZ.

DATE SURVEYED JUNE 1980

APPROVED

NOTE - CONTOURS AT LOGARITHMIC INTERVALS 1, -1.5, -2, -3, -5, -7.5, -10

DATE 1/7/81

Expiry Date: February 25, 1981

PHOENIX GEOPHYSICS LIMITED

INDUCED POLARIZATION AND RESISTIVITY SURVEY

| EAGLE CLAIMS LINE-200W | | | | | | | | | | | | X=100M | | RHO (OHM-M) | |
|------------------------|------|------|------|------|------|------|-----|------|------|------|------|--------|-----|-------------|--|
| DIPOLE NUMBER | 2 | 3 | 4 | 5 | 6 | 7 | 8 | 9 | 10 | 11 | 12 | | | | |
| COORDINATE | 500S | 300S | 100S | 100N | 300N | 500N | | | | | | | | | |
| INTERPRETATION | | | | | | | | | | | | | | | |
| N=1 | 796 | 535 | 676 | 524 | 671 | 584 | 760 | 548 | 741 | 546 | 637 | 972 | N=1 | | |
| N=2 | 518 | 585 | 652 | 616 | 591 | 625 | 696 | 778 | 585 | 579 | 1385 | N=2 | | | |
| N=3 | 633 | 555 | 760 | 511 | 606 | 594 | 950 | 608 | 665 | 1321 | N=3 | | | | |
| N=4 | 577 | 610 | 599 | 500 | 577 | 735 | 705 | 791 | 1445 | N=4 | | | | | |
| N=5 | 660 | 488 | 570 | 468 | 699 | 525 | 966 | 1581 | N=5 | | | | | | |

| EAGLE CLAIMS LINE-200W | | | | | | | | | | | | X=100M | | PFE | |
|------------------------|------|------|------|------|------|------|-----|-----|-----|-----|-----|--------|-----|-----|--|
| DIPOLE NUMBER | 2 | 3 | 4 | 5 | 6 | 7 | 8 | 9 | 10 | 11 | 12 | | | | |
| COORDINATE | 500S | 300S | 100S | 100N | 300N | 500N | | | | | | | | | |
| INTERPRETATION | | | | | | | | | | | | | | | |
| N=1 | 6.5 | 5.6 | 4.0 | 3.3 | 3.6 | 4.5 | 2.6 | 3.0 | 2.5 | 2.6 | 1.4 | 1.7 | N=1 | | |
| N=2 | 5.3 | 5.0 | 3.8 | 3.8 | 3.0 | 4.0 | 2.6 | 2.3 | 2.9 | 2.6 | 2.8 | N=2 | | | |
| N=3 | 5.0 | 4.3 | 3.6 | 3.4 | 3.0 | 4.0 | 2.1 | 2.5 | 2.5 | 2.5 | N=3 | | | | |
| N=4 | 4.6 | 4.1 | 3.5 | 3.3 | 3.3 | 3.0 | 2.1 | 3.9 | 2.5 | N=4 | | | | | |
| N=5 | 4.3 | 4.0 | 3.3 | 4.3 | 2.6 | 3.2 | 2.7 | 3.0 | N=5 | | | | | | |

| EAGLE CLAIMS LINE-200W | | | | | | | | | | | | X=100M | | METAL FACTOR | |
|------------------------|------|------|------|------|------|------|-----|-----|-----|-----|-----|--------|-----|--------------|--|
| DIPOLE NUMBER | 2 | 3 | 4 | 5 | 6 | 7 | 8 | 9 | 10 | 11 | 12 | | | | |
| COORDINATE | 500S | 300S | 100S | 100N | 300N | 500N | | | | | | | | | |
| INTERPRETATION | | | | | | | | | | | | | | | |
| N=1 | 8.1 | 10 | 5.9 | 6.2 | 5.3 | 7.6 | 3.4 | 5.4 | 3.3 | 4.7 | 2.1 | 1.7 | N=1 | | |
| N=2 | 10 | 8.5 | 5.8 | 6.1 | 5.0 | 6.4 | 3.7 | 2.9 | 4.9 | 4.4 | 2.0 | N=2 | | | |
| N=3 | 7.8 | 7.7 | 4.7 | 6.6 | 4.9 | 6.7 | 2.2 | 4.1 | 3.7 | 1.8 | N=3 | | | | |
| N=4 | 7.9 | 6.7 | 5.8 | 6.5 | 5.7 | 4.0 | 2.9 | 4.9 | 1.7 | N=4 | | | | | |
| N=5 | 6.5 | 8.1 | 5.7 | 9.1 | 3.7 | 6.0 | 2.7 | 1.8 | N=5 | | | | | | |

CORDILLERAN ENGINEERING LTD.

EAGLE CLAIM GROUP, WATSON LAKE M.D.

YUKON TERRITORY

LINE NO. - 0

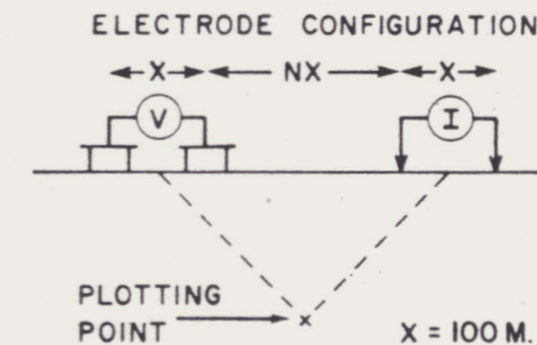

SURFACE PROJECTION OF ANOMALOUS ZONE

DEFINITE 
 PROBABLE 
 POSSIBLE 

FREQUENCIES 0.3 - 5.0 HZ.

DATE SURVEYED JUNE 1980

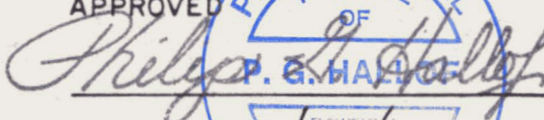
APPROVED 

DATE 17/81

Expiry Date: February 25, 1981

NOTE - CONTOURS AT LOGARITHMIC INTERVALS 1, -1.5, -2, -3, -5, -7.5, -10

PHOENIX GEOPHYSICS LIMITED

INDUCED POLARIZATION AND RESISTIVITY SURVEY

| EAGLE CLAIMS LINE-0 | | | | | | | | | | | | | |
|---------------------|------|------|------|------|------|------|-----|------|-----|-----|-----|-----|-----|
| X=100M RHO (OHM-M) | | | | | | | | | | | | | |
| DIPOLE NUMBER | 2 | 3 | 4 | 5 | 6 | 7 | 8 | 9 | 10 | 11 | 12 | | |
| COORDINATE | 500S | 300S | 100S | 100N | 300N | 500N | | | | | | | |
| N=1 | 650 | 649 | 536 | 541 | 422 | 397 | 496 | 575 | 734 | 660 | 390 | 712 | N=1 |
| N=2 | 581 | 537 | 678 | 494 | 425 | 551 | 562 | 858 | 720 | 375 | 924 | | N=2 |
| N=3 | 504 | 589 | 580 | 487 | 475 | 665 | 906 | 808 | 431 | 857 | | | N=3 |
| N=4 | 627 | 526 | 564 | 538 | 526 | 1026 | 818 | 539 | 979 | | | | N=4 |
| N=5 | 558 | 495 | 590 | 577 | 786 | 891 | 609 | 1191 | | | | | N=5 |

| EAGLE CLAIMS LINE-0 | | | | | | | | | | | | | |
|---------------------|------|------|------|------|------|------|-----|-----|-----|-----|-----|-----|-----|
| X=100M PFE | | | | | | | | | | | | | |
| DIPOLE NUMBER | 2 | 3 | 4 | 5 | 6 | 7 | 8 | 9 | 10 | 11 | 12 | | |
| COORDINATE | 500S | 300S | 100S | 100N | 300N | 500N | | | | | | | |
| N=1 | 5.5 | 6.0 | 6.3 | 6.0 | 4.2 | 5.6 | 3.9 | 3.8 | 4.2 | 3.6 | 3.1 | 1.6 | N=1 |
| N=2 | 5.5 | 5.8 | 5.9 | 5.2 | 4.6 | 4.1 | 3.5 | 4.1 | 3.8 | 3.1 | 2.3 | | N=2 |
| N=3 | 4.6 | 5.2 | 4.5 | 5.1 | 3.6 | 3.9 | 3.2 | 4.1 | 3.6 | 3.1 | | | N=3 |
| N=4 | 4.0 | 4.0 | 5.0 | 3.9 | 3.3 | 4.0 | 3.5 | 4.1 | 3.2 | | | | N=4 |
| N=5 | 3.2 | 4.1 | 4.4 | 3.9 | 3.3 | 4.0 | 3.5 | 3.8 | | | | | N=5 |

| EAGLE CLAIMS LINE-0 | | | | | | | | | | | | | |
|---------------------|------|------|------|------|------|------|-----|-----|-----|-----|-----|-----|-----|
| X=100M METAL FACTOR | | | | | | | | | | | | | |
| DIPOLE NUMBER | 2 | 3 | 4 | 5 | 6 | 7 | 8 | 9 | 10 | 11 | 12 | | |
| COORDINATE | 500S | 300S | 100S | 100N | 300N | 500N | | | | | | | |
| N=1 | 8.4 | 9.2 | 12 | 11 | 9.9 | 14 | 7.8 | 6.6 | 5.7 | 5.4 | 7.9 | 2.2 | N=1 |
| N=2 | 9.4 | 17 | 8.6 | 11 | 11 | 7.4 | 6.2 | 4.7 | 5.2 | 8.2 | 2.4 | | N=2 |
| N=3 | 9.1 | 8.8 | 7.7 | 10 | 7.5 | 5.8 | 3.5 | 5.0 | 8.3 | 3.6 | | | N=3 |
| N=4 | 6.3 | 7.6 | 8.8 | 7.2 | 6.2 | 3.8 | 4.2 | 7.6 | 3.2 | | | | N=4 |
| N=5 | 5.7 | 8.2 | 7.4 | 6.4 | 4.1 | 4.4 | 5.7 | 3.1 | | | | | N=5 |

CORDILLERAN ENGINEERING LTD.

EAGLE CLAIM GROUP, WATSON LAKE M.D.

YUKON TERRITORY

LINE NO. - 200E

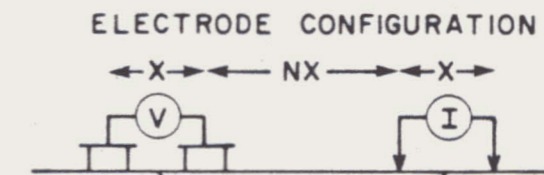

PLOTTING POINT X = 100 M.

SURFACE PROJECTION OF ANOMALOUS ZONE

DEFINITE
 PROBABLE
 POSSIBLE

FREQUENCIES 0.3 - 5.0 HZ.

DATE SURVEYED JUNE 1980

APPROVED

NOTE - CONTOURS AT LOGARITHMIC INTERVALS 1, -1.5, -2, -3, -5, -7.5, -10

DATE 1/7/81

Expiry Date: February 25, 1981

PHOENIX GEOPHYSICS LIMITED

INDUCED POLARIZATION AND RESISTIVITY SURVEY

| EAGLE CLAIMS LINE-200E | | | | | | | | | | | | X=100M | | RHO (OHM-M) | |
|------------------------|------|------|------|------|------|------|------|-----|-----|-----|-----|--------|-----|-------------|--|
| DIPOLE NUMBER | 2 | 3 | 4 | 5 | 6 | 7 | 8 | 9 | 10 | 11 | 12 | | | | |
| COORDINATE | 500S | 300S | 100S | 100N | 300N | 500N | | | | | | | | | |
| INTERPRETATION | | | | | | | | | | | | | | | |
| N=1 | 738 | 462 | 610 | 456 | 658 | 452 | 669 | 486 | 878 | 400 | 869 | 401 | N=1 | | |
| N=2 | 587 | 410 | 427 | 894 | 531 | 516 | 536 | 819 | 609 | 353 | 836 | N=2 | | | |
| N=3 | 542 | 313 | 820 | 629 | 588 | 416 | 1057 | 565 | 522 | 440 | N=3 | | | | |
| N=4 | 437 | 539 | 618 | 709 | 479 | 833 | 706 | 520 | 698 | N=4 | | | | | |
| N=5 | 723 | 429 | 638 | 528 | 981 | 528 | 675 | 730 | N=5 | | | | | | |

| EAGLE CLAIMS LINE-200E | | | | | | | | | | | | X=100M | | PFE | |
|------------------------|------|------|------|------|------|------|-----|-----|-----|-----|-----|--------|-----|-----|--|
| DIPOLE NUMBER | 2 | 3 | 4 | 5 | 6 | 7 | 8 | 9 | 10 | 11 | 12 | | | | |
| COORDINATE | 500S | 300S | 100S | 100N | 300N | 500N | | | | | | | | | |
| INTERPRETATION | | | | | | | | | | | | | | | |
| N=1 | 2.5 | 3.2 | 3.9 | 1.5 | 2.9 | 3.0 | 3.2 | 3.9 | 6.2 | 6.6 | 2.3 | 3.7 | N=1 | | |
| N=2 | 2.6 | 3.8 | 5.0 | 2.5 | 2.0 | 2.6 | 4.5 | 5.8 | 3.8 | 5.6 | 3.8 | N=2 | | | |
| N=3 | 3.3 | 4.5 | 5.9 | 2.4 | 2.3 | 4.0 | 4.9 | 3.4 | 3.3 | 6.2 | N=3 | | | | |
| N=4 | 3.9 | 5.0 | 6.0 | 2.9 | 4.0 | 3.7 | 2.5 | 2.9 | 4.3 | N=4 | | | | | |
| N=5 | 4.4 | 4.4 | 2.5 | 4.6 | 3.2 | 1.5 | 2.5 | 4.0 | N=5 | | | | | | |

POND

TOPOGRAPHY

● ELECTRODE POSITION EAST OF LINE BY 30M.

| EAGLE CLAIMS LINE-200E | | | | | | | | | | | | X=100M | | METAL FACTOR | |
|------------------------|------|------|------|------|------|------|-----|-----|-----|-----|-----|--------|-----|--------------|--|
| DIPOLE NUMBER | 2 | 3 | 4 | 5 | 6 | 7 | 8 | 9 | 10 | 11 | 12 | | | | |
| COORDINATE | 500S | 300S | 100S | 100N | 300N | 500N | | | | | | | | | |
| INTERPRETATION | | | | | | | | | | | | | | | |
| N=1 | 3.3 | 6.9 | 6.3 | 3.2 | 4.4 | 6.6 | 4.7 | 8.0 | 7.0 | 17 | 2.6 | 9.2 | N=1 | | |
| N=2 | 4.4 | 9.2 | 11 | 2.7 | 3.7 | 5.0 | 8.3 | 7.0 | 6.2 | 16 | 4.5 | N=2 | | | |
| N=3 | 6.0 | 14 | 7.1 | 3.8 | 3.9 | 9.5 | 4.6 | 6.0 | 6.3 | 14 | N=3 | | | | |
| N=4 | 8.9 | 9.2 | 9.6 | 4.0 | 8.3 | 4.4 | 3.5 | 5.5 | 6.1 | N=4 | | | | | |
| N=5 | 6.0 | 10 | 3.9 | 8.7 | 3.2 | 2.8 | 3.7 | 5.4 | N=5 | | | | | | |

CORDILLERAN ENGINEERING LTD.

EAGLE CLAIM GROUP, WATSON LAKE M.D.

YUKON TERRITORY

LINE NO. - 200E

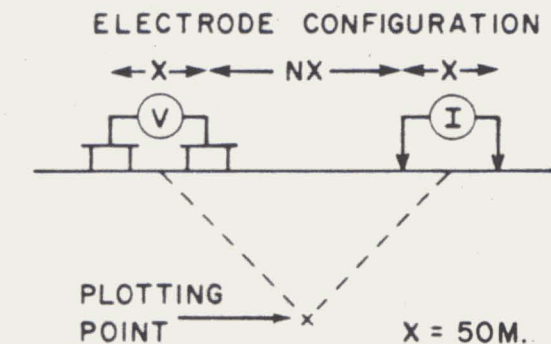

SURFACE PROJECTION OF ANOMALOUS ZONE

DEFINITE **—————**
 PROBABLE **.....**
 POSSIBLE **///////**

FREQUENCIES 0.3 - 5.0 HZ.

DATE SURVEYED JUNE 1980

APPROVED *Philip P. G. Hall*

NOTE - CONTOURS AT LOGARITHMIC INTERVALS 1, -1.5, -2, -3, -5, -7.5, -10

DATE 1/7/81

Expiry Date: February 25, 1981

PHOENIX GEOPHYSICS LIMITED

INDUCED POLARIZATION AND RESISTIVITY SURVEY

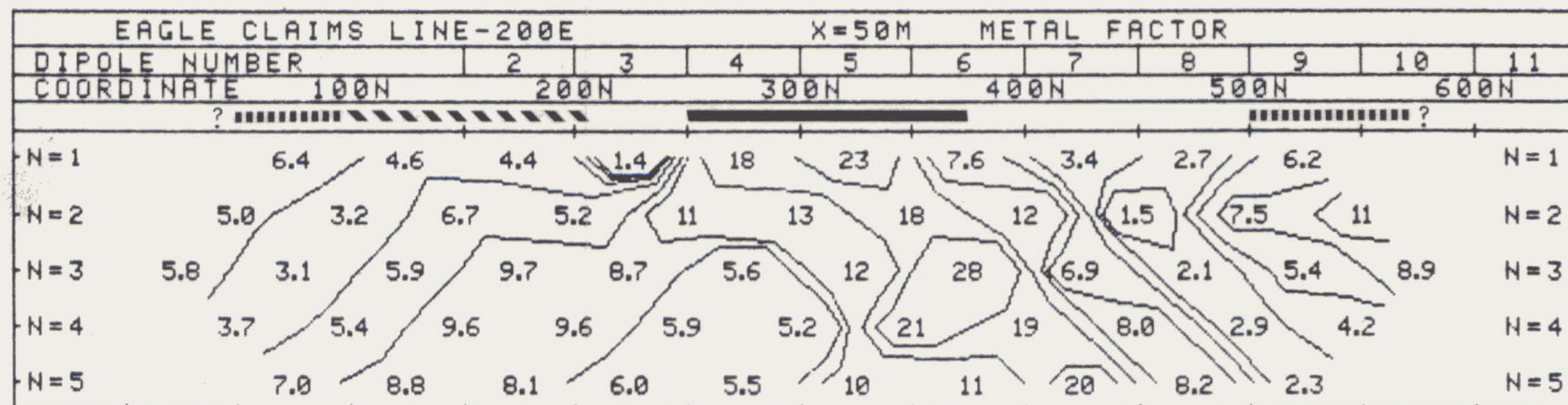
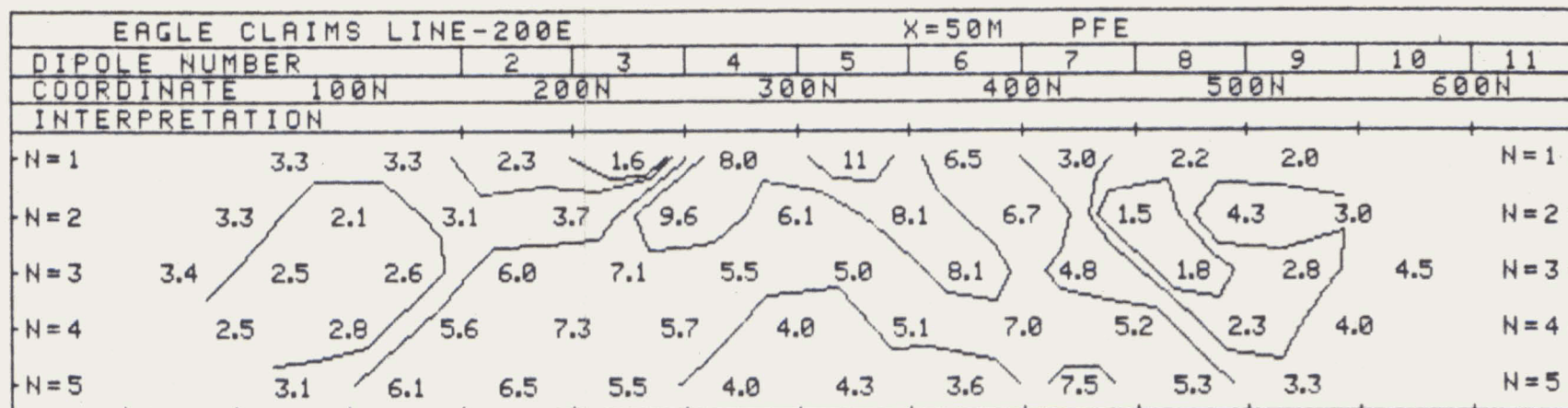
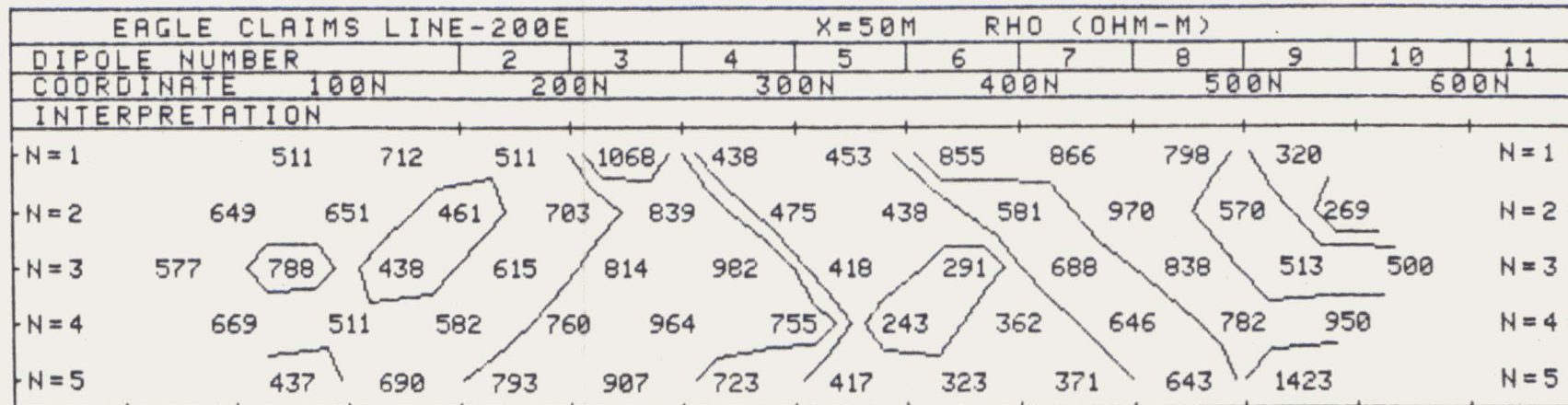

CORDILLERAN ENGINEERING LTD.

EAGLE CLAIM GROUP, WATSON LAKE M.D.

YUKON TERRITORY

LINE NO. - 390E

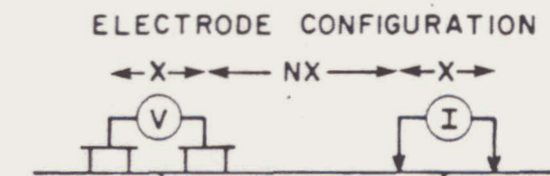

PLOTTING POINT X = 100 M.

SURFACE PROJECTION OF ANOMALOUS ZONE

DEFINITE
 PROBABLE
 POSSIBLE

FREQUENCIES 0.3-5.0 HZ.

DATE SURVEYED JUNE 1980

APPROVED

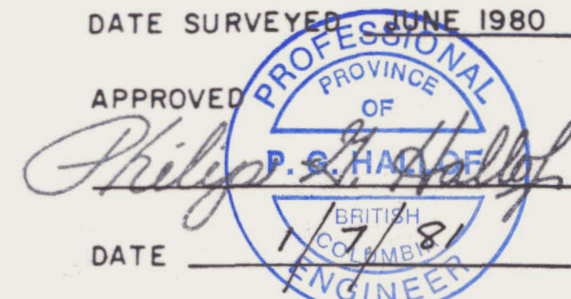

NOTE - CONTOURS AT LOGARITHMIC INTERVALS 1, -1.5, -2, -3, -5, -7.5, -10

DATE

Expiry Date: February 25, 1981

PHOENIX GEOPHYSICS LIMITED

INDUCED POLARIZATION AND RESISTIVITY SURVEY

| EAGLE CLAIMS LINE-390E | | | | | | | | | | | | X=100M | | RHO (OHM-M) | |
|------------------------|------|------|------|------|------|------|-----|-----|-----|-----|-----|--------|-----|-------------|--|
| DIPOLE NUMBER | 2 | 3 | 4 | 5 | 6 | 7 | 8 | 9 | 10 | 11 | 12 | | | | |
| COORDINATE | 500S | 300S | 100S | 100N | 300N | 500N | | | | | | | | | |
| INTERPRETATION | | | | | | | | | | | | | | | |
| N=1 | 531 | 520 | 496 | 501 | 623 | 791 | 478 | 399 | 535 | 535 | 445 | 372 | N=1 | | |
| N=2 | 562 | 519 | 562 | 644 | 672 | 507 | 400 | 594 | 690 | 521 | 500 | N=2 | | | |
| N=3 | 526 | 564 | 653 | 665 | 489 | 458 | 606 | 786 | 680 | 492 | N=3 | | | | |
| N=4 | 536 | 617 | 701 | 508 | 460 | 670 | 785 | 799 | 650 | N=4 | | | | | |
| N=5 | 605 | 648 | 523 | 475 | 660 | 825 | 748 | 796 | N=5 | | | | | | |

| EAGLE CLAIMS LINE-390E | | | | | | | | | | | | X=100M | | PFE | |
|------------------------|------|------|------|------|------|------|-----|-----|-----|-----|-----|--------|-----|-----|--|
| DIPOLE NUMBER | 2 | 3 | 4 | 5 | 6 | 7 | 8 | 9 | 10 | 11 | 12 | | | | |
| COORDINATE | 500S | 300S | 100S | 100N | 300N | 500N | | | | | | | | | |
| INTERPRETATION | | | | | | | | | | | | | | | |
| N=1 | 4.3 | 5.7 | 4.5 | 3.7 | 3.0 | 3.0 | 2.0 | 2.9 | 5.0 | 5.5 | 2.0 | 1.0 | N=1 | | |
| N=2 | 3.2 | 5.4 | 4.0 | 3.0 | 2.1 | 3.0 | 3.9 | 5.1 | 4.0 | 4.8 | 2.6 | N=2 | | | |
| N=3 | 2.7 | 4.7 | 4.0 | 2.8 | 3.4 | 4.7 | 4.4 | 2.1 | 3.6 | 4.5 | N=3 | | | | |
| N=4 | 3.5 | 4.5 | 4.1 | 3.9 | 5.0 | 5.5 | 1.7 | 2.0 | 4.6 | N=4 | | | | | |
| N=5 | 4.2 | 5.6 | 12 | 5.5 | 4.7 | 1.5 | 1.7 | 3.1 | N=5 | | | | | | |

CREEK

TOPOGRAPHY

| EAGLE CLAIMS LINE-390E | | | | | | | | | | | | X=100M | | METAL FACTOR | |
|------------------------|------|------|------|------|------|------|-----|-----|-----|-----|-----|--------|-----|--------------|--|
| DIPOLE NUMBER | 2 | 3 | 4 | 5 | 6 | 7 | 8 | 9 | 10 | 11 | 12 | | | | |
| COORDINATE | 500S | 300S | 100S | 100N | 300N | 500N | | | | | | | | | |
| INTERPRETATION | | | | | | | | | | | | | | | |
| N=1 | 8.0 | 11 | 9.0 | 7.3 | 4.8 | 3.7 | 4.1 | 7.2 | 9.3 | 10 | 4.4 | 2.6 | N=1 | | |
| N=2 | 5.6 | 10 | 7.1 | 4.6 | 3.1 | 5.9 | 9.7 | 8.5 | 5.7 | 9.2 | 5.2 | N=2 | | | |
| N=3 | 5.1 | 8.3 | 6.1 | 4.2 | 6.9 | 10 | 7.2 | 2.6 | 5.2 | 9.1 | N=3 | | | | |
| N=4 | 6.5 | 7.2 | 5.8 | 7.6 | 11 | 8.2 | 2.1 | 2.5 | 7.0 | N=4 | | | | | |
| N=5 | 6.9 | 7.7 | 6.3 | 12 | 7.1 | 1.8 | 2.2 | 3.8 | N=5 | | | | | | |

CORDILLERAN ENGINEERING LTD.

EAGLE CLAIM GROUP, WATSON LAKE M.D.

YUKON TERRITORY

LINE NO. - 600E

ELECTRODE CONFIGURATION

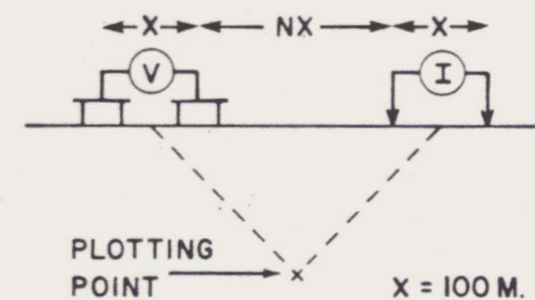

SURFACE PROJECTION OF ANOMALOUS ZONE

DEFINITE
 PROBABLE
 POSSIBLE

FREQUENCIES 0.3-5.0 HZ.

DATE SURVEYED JUNE 1980

APPROVED

Philip G. Hall
 P. G. HALL
 BRITISH COLUMBIA
 ENGINEER

NOTE - CONTOURS AT LOGARITHMIC INTERVALS 1, -1.5, -2, -3, -5, -7.5, -10

DATE

Expiry Date: February 25, 1981

PHOENIX GEOPHYSICS LIMITED

INDUCED POLARIZATION AND RESISTIVITY SURVEY

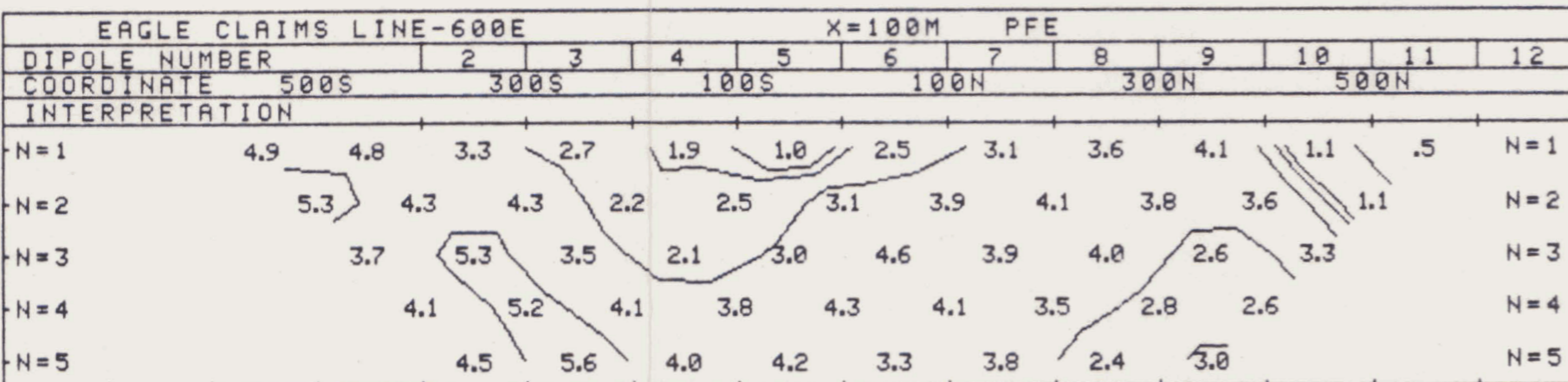
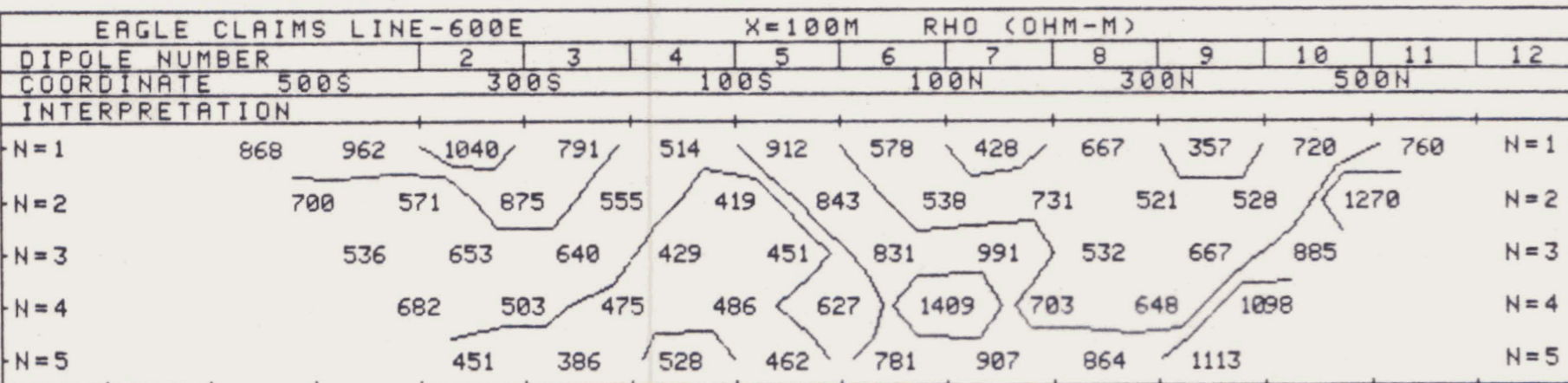

CREEK

TOPOGRAPHY

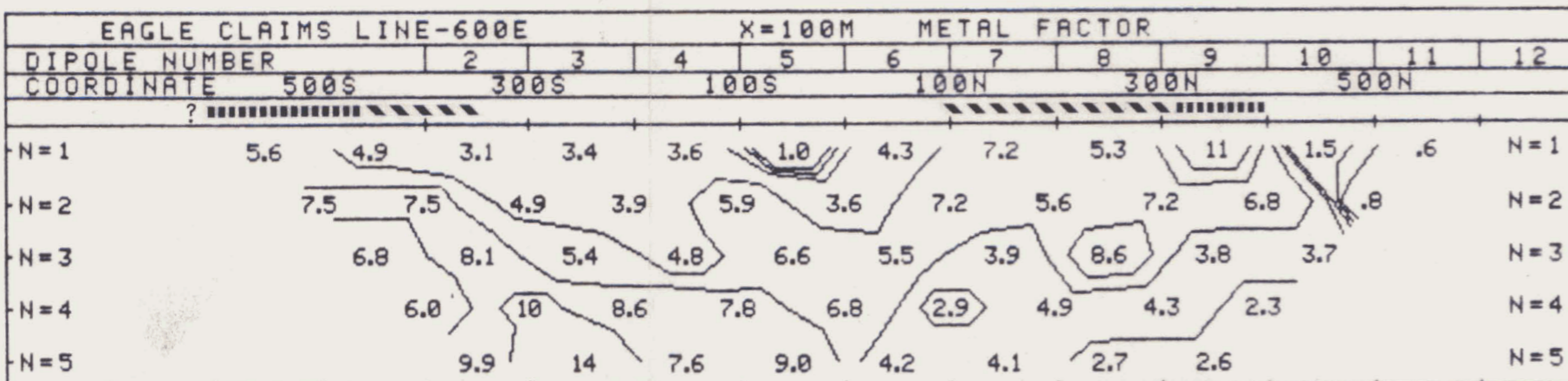

CORDILLERAN ENGINEERING LTD.

EAGLE CLAIM GROUP, WATSON LAKE M.D.

YUKON TERRITORY

LINE NO. - 800E

ELECTRODE CONFIGURATION

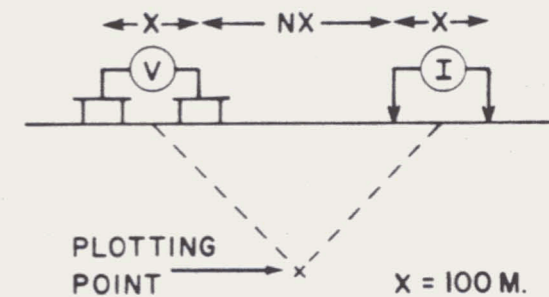

SURFACE PROJECTION OF ANOMALOUS ZONE

DEFINITE

PROBABLE

POSSIBLE

FREQUENCIES 0.3-5.0 HZ.

DATE SURVEYED JUNE 1980

APPROVED

NOTE - CONTOURS AT LOGARITHMIC INTERVALS 1, -1.5, -2, -3, -5, -7.5, -10

DATE 17/81

Expiry Date: February 25, 1981

PHOENIX GEOPHYSICS LIMITED

INDUCED POLARIZATION AND RESISTIVITY SURVEY

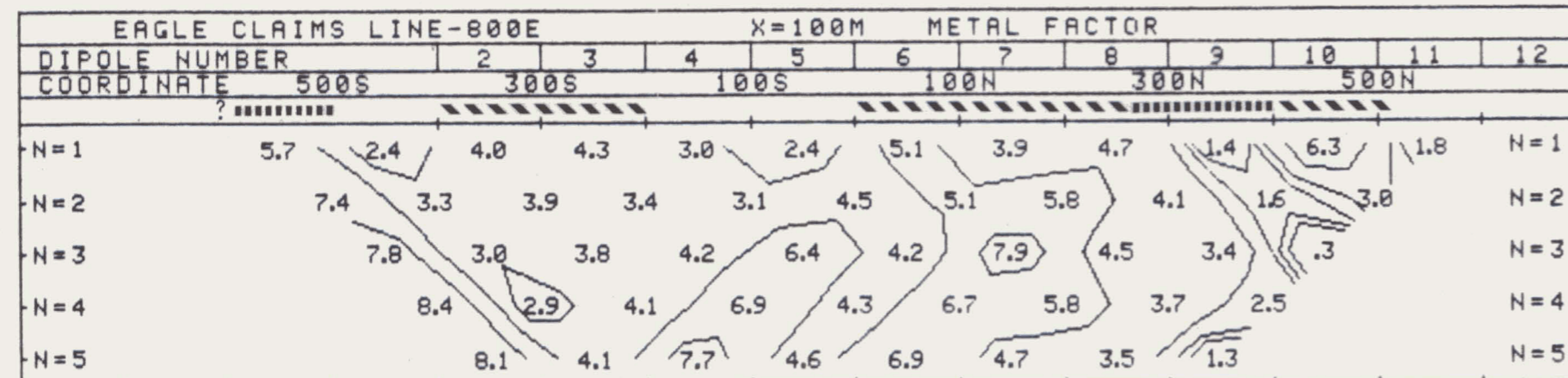
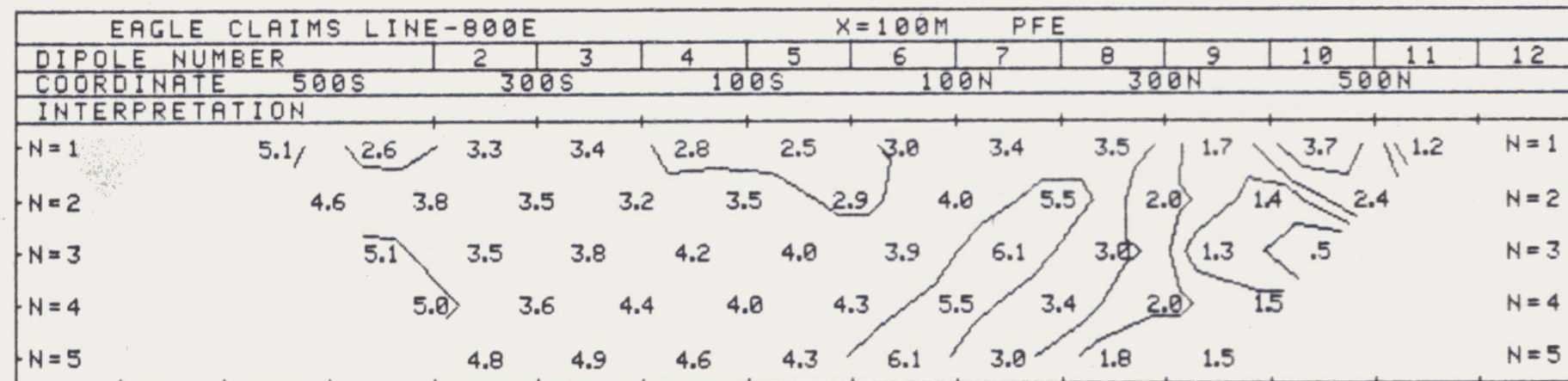
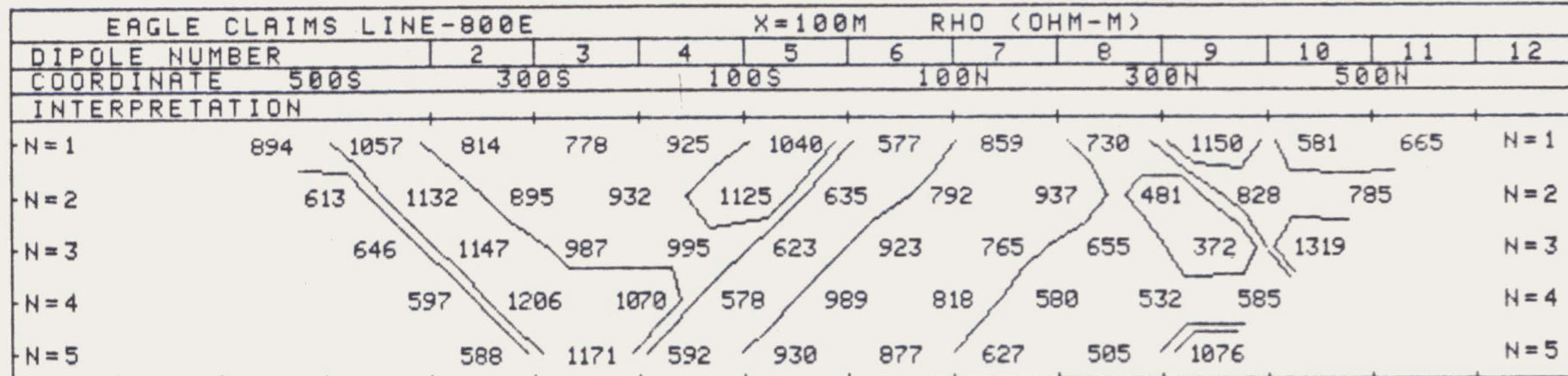

CORDILLERAN ENGINEERING LTD.

EAGLE CLAIM GROUP, WATSON LAKE M.D.

YUKON TERRITORY

LINE NO. - 1000E

ELECTRODE CONFIGURATION

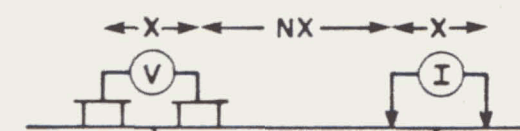

PLOTTING POINT x X = 100 M.

SURFACE PROJECTION OF ANOMALOUS ZONE

DEFINITE
 PROBABLE
 POSSIBLE

FREQUENCIES 0.3-5.0 HZ.

DATE SURVEYED JUNE 1980

APPROVED



NOTE - CONTOURS AT LOGARITHMIC INTERVALS 1, -1.5, -2, -3, -5, -7.5, -10

DATE

Expiry Date: February 25, 1981

PHOENIX GEOPHYSICS LIMITED

INDUCED POLARIZATION AND RESISTIVITY SURVEY

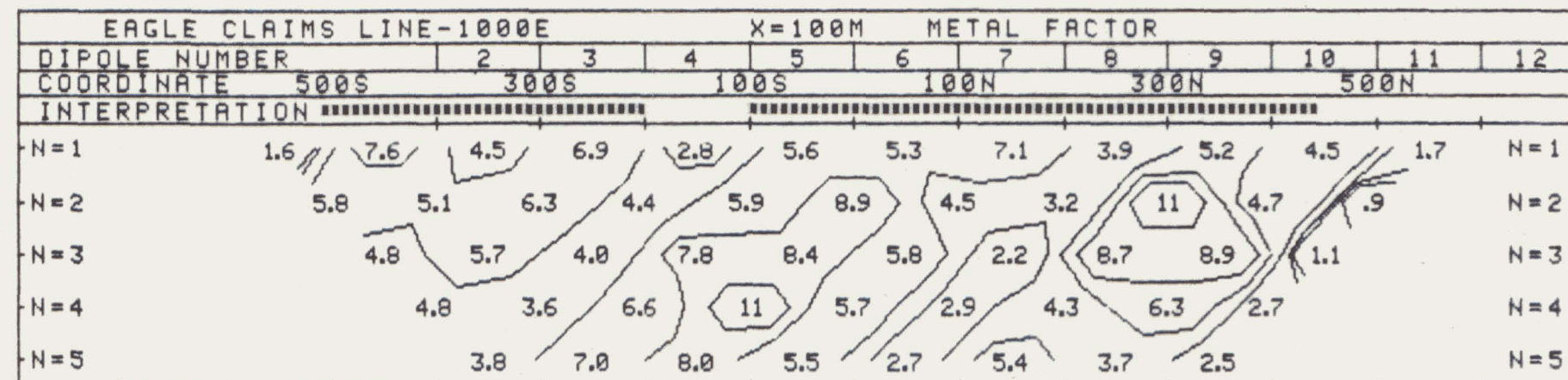
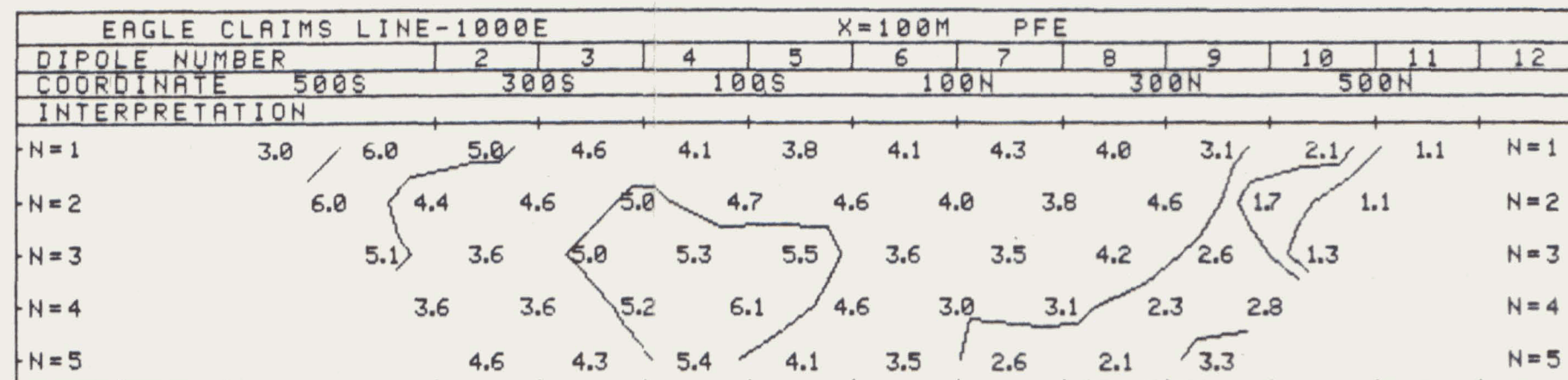
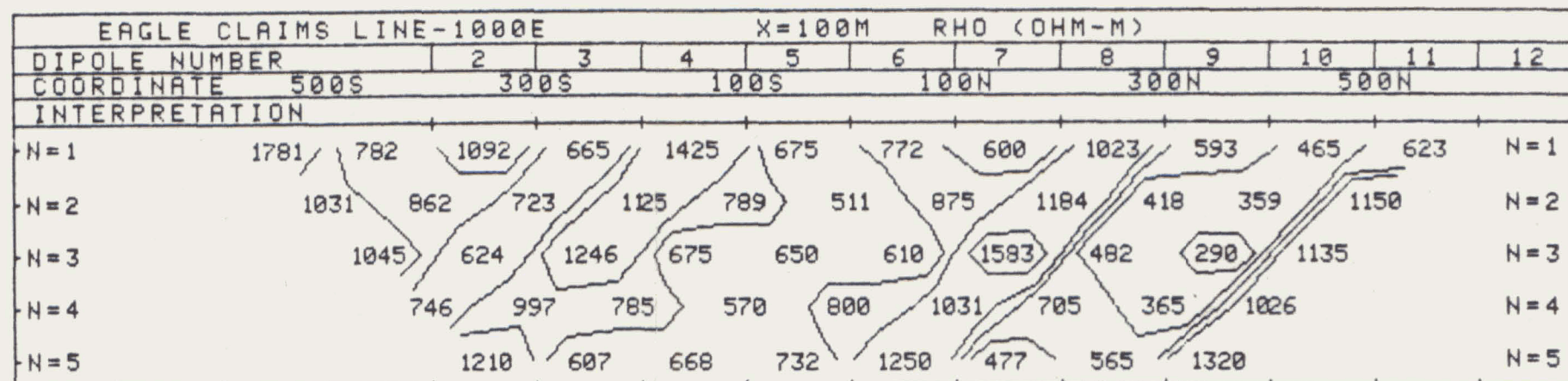

CORDILLERAN ENGINEERING LTD.

EAGLE CLAIM GROUP, WATSON LAKE M.D.

YUKON TERRITORY

LINE NO. - 1200E

ELECTRODE CONFIGURATION

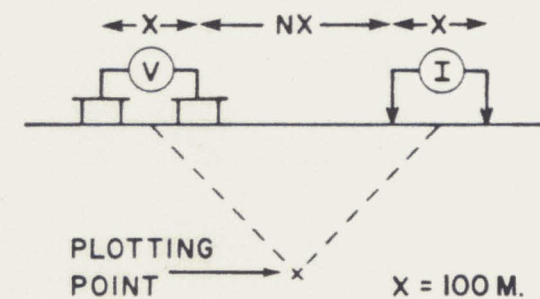

SURFACE PROJECTION OF ANOMALOUS ZONE

DEFINITE **—————**
 PROBABLE **.....**
 POSSIBLE **///////**

FREQUENCIES 0.3-5.0 HZ.

DATE SURVEYED JUNE 1980

APPROVED *P. G. HALLOF*

P. G. HALLOF

NOTE - CONTOURS AT LOGARITHMIC INTERVALS 1, -1.5, -2, -3, -5, -7.5, -10

DATE 7/7/81

Expiry Date: February 25, 1981

PHOENIX GEOPHYSICS LIMITED

INDUCED POLARIZATION AND RESISTIVITY SURVEY

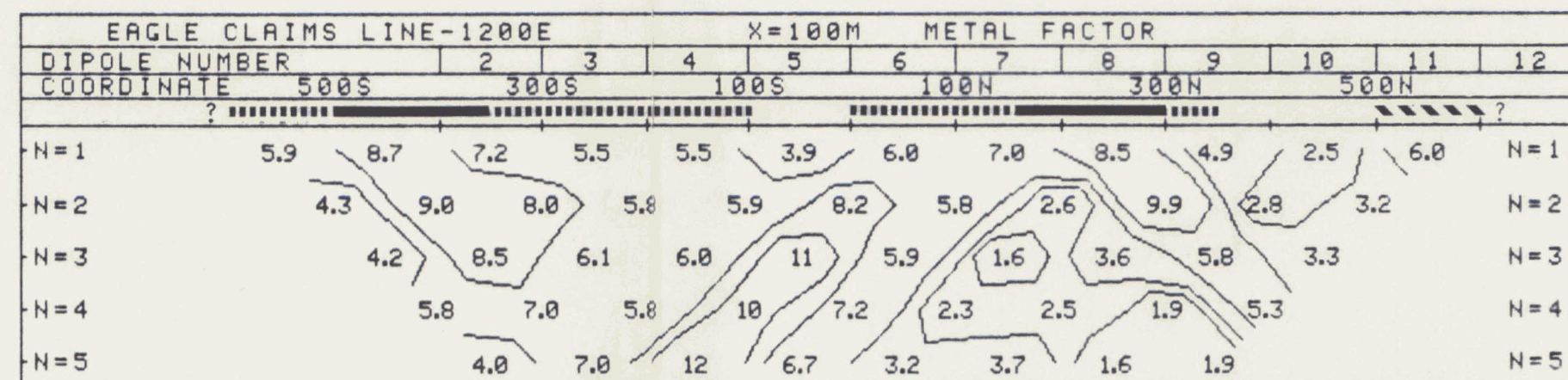
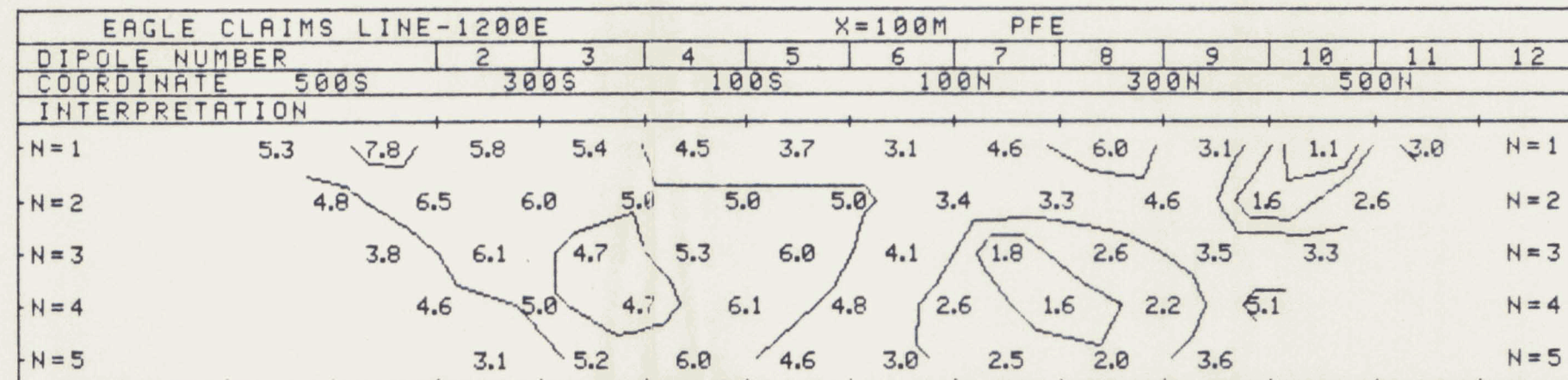
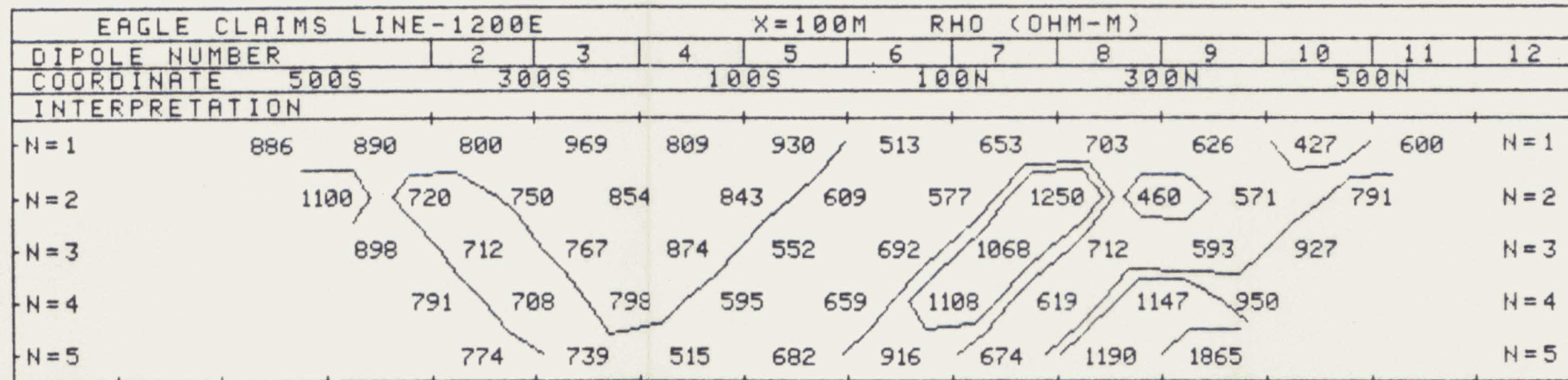

CORDILLERAN ENGINEERING LTD.

EAGLE CLAIM GROUP, WATSON LAKE M.D.

YUKON TERRITORY

LINE NO. - 1400E

ELECTRODE CONFIGURATION

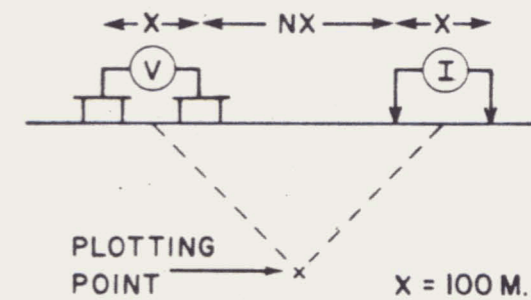

SURFACE PROJECTION OF ANOMALOUS ZONE

DEFINITE **—————**
 PROBABLE **.....**
 POSSIBLE **///////**

FREQUENCIES 0.3-5.0 HZ.

DATE SURVEYED JUNE 1980

APPROVED *Philip P. G. Hall*

NOTE - CONTOURS AT LOGARITHMIC INTERVALS 1, -1.5, -2, -3, -5, -7.5, -10

DATE 1/7/81

Expiry Date: February 25, 1981

PHOENIX GEOPHYSICS LIMITED

INDUCED POLARIZATION AND RESISTIVITY SURVEY

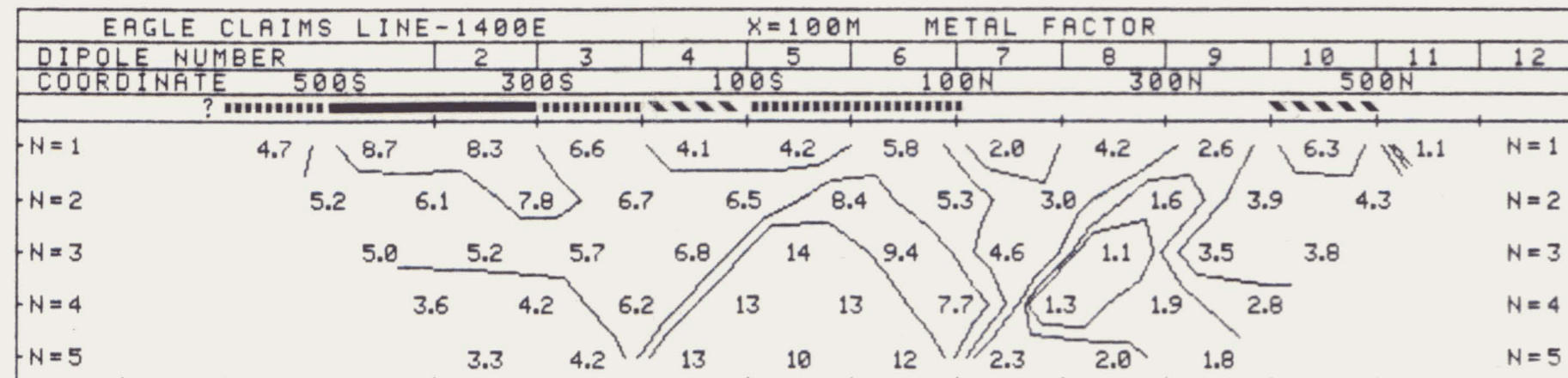
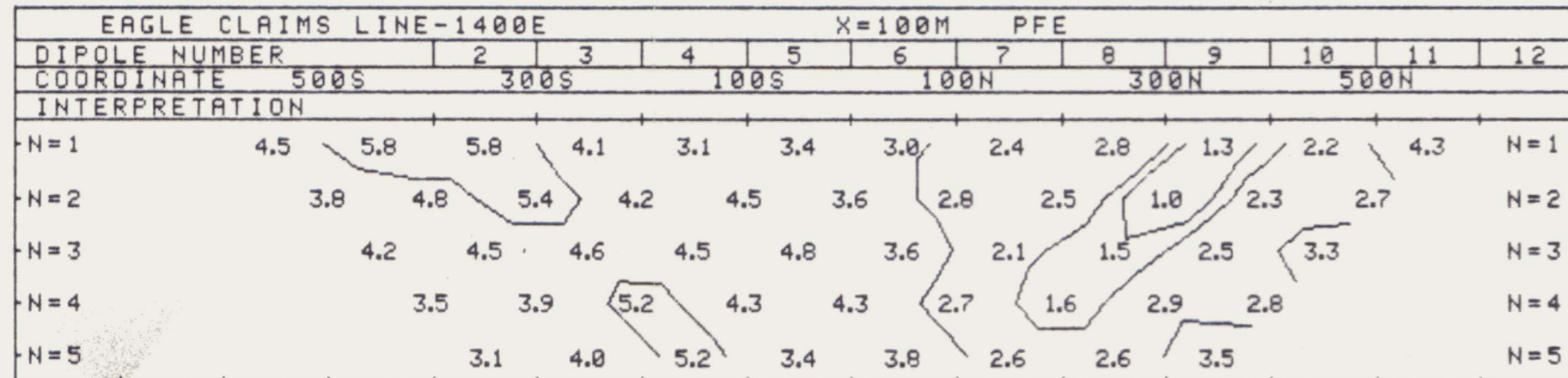
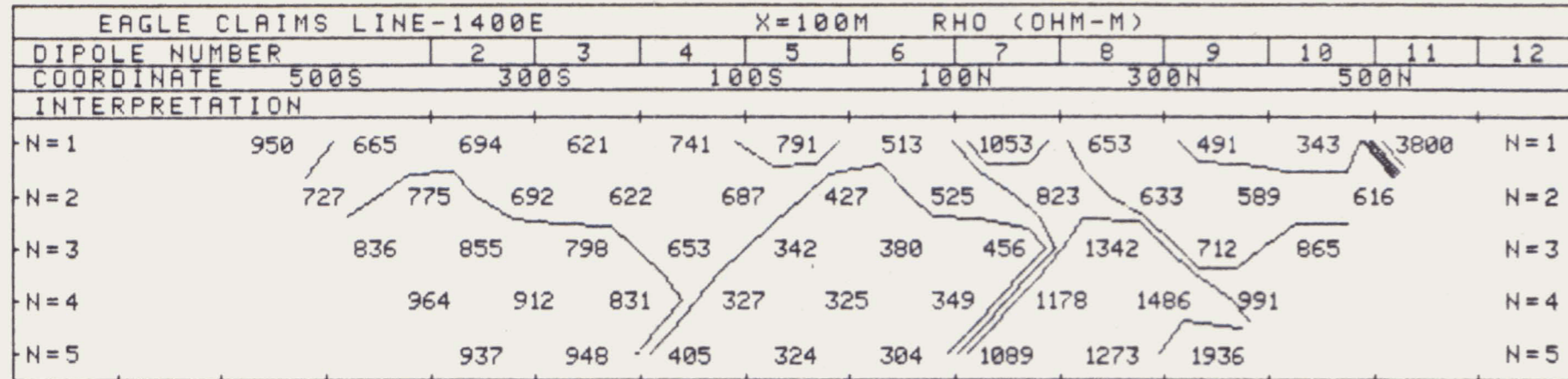

CORDILLERAN ENGINEERING LTD.

EAGLE CLAIM GROUP, WATSON LAKE M.D.

YUKON TERRITORY

LINE NO. - 1400W

LINE NO. - 1200W

LINE NO. - 1000W

VLF-EM SURVEY - LINE PROFILE

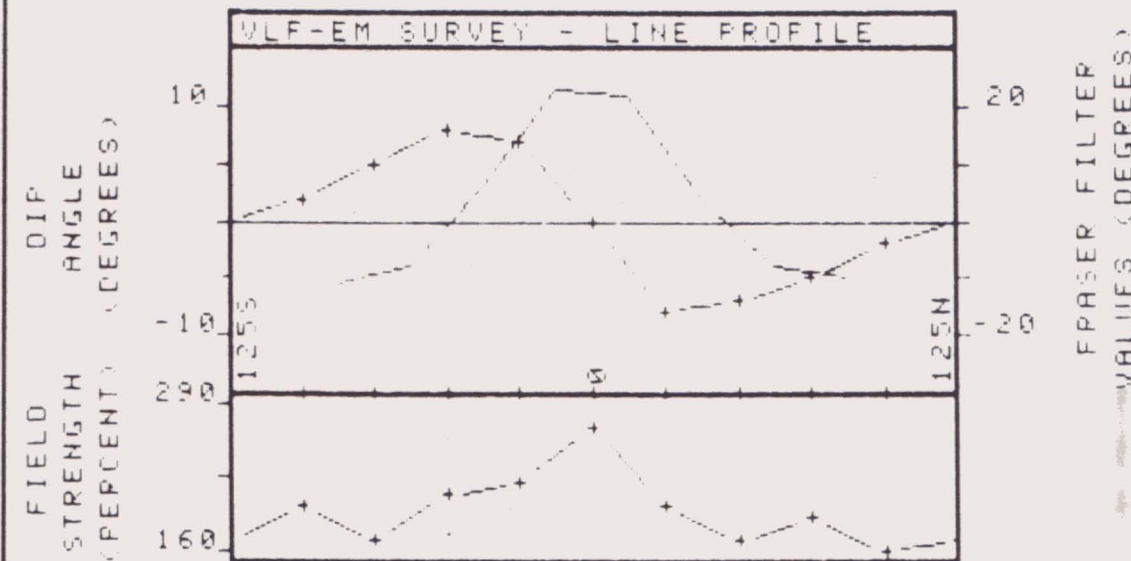

CONDUCTOR SYMBOLS

- DEFINITE
- PROBABLE
- POSSIBLE

15 PEAK AMPLITUDE IN GAMMAS

DATE SURVEYED JULY 1980

APPROVED

P. G. HALLOP
PROFESSIONAL ENGINEER
PROVINCE OF BRITISH COLUMBIA

DATE

Expiry Date: February 25, 1981

PHOENIX GEOPHYSICS LIMITED

VLF - ELECTROMAGNETIC SURVEY

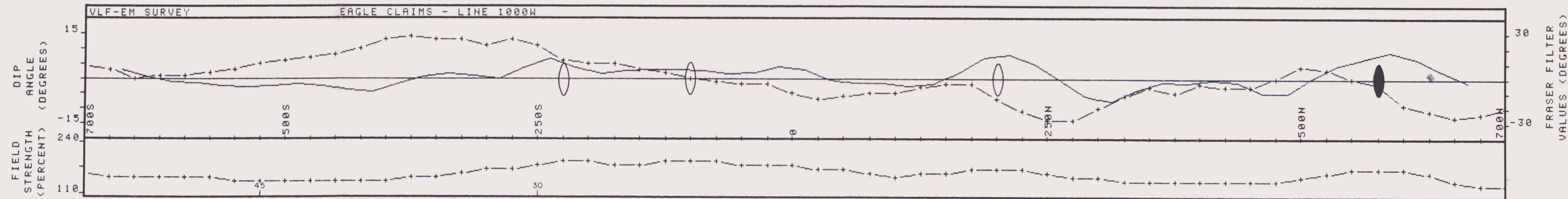
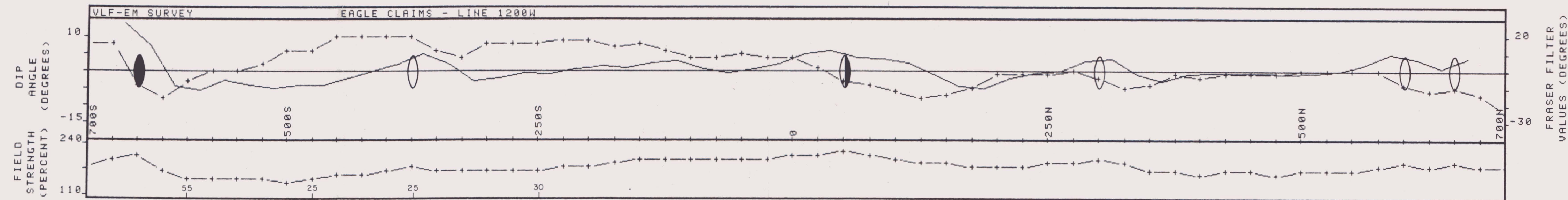
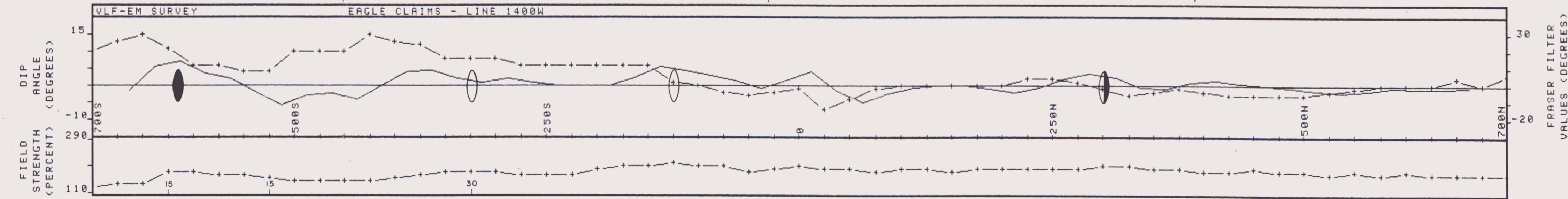

CORDILLERAN ENGINEERING LTD.

EAGLE CLAIM GROUP, WATSON LAKE M.D.

YUKON TERRITORY

LINE NO. - 800W

LINE NO. - 600W

LINE NO. - 400W

VLF-EM SURVEY - LINE PROFILE

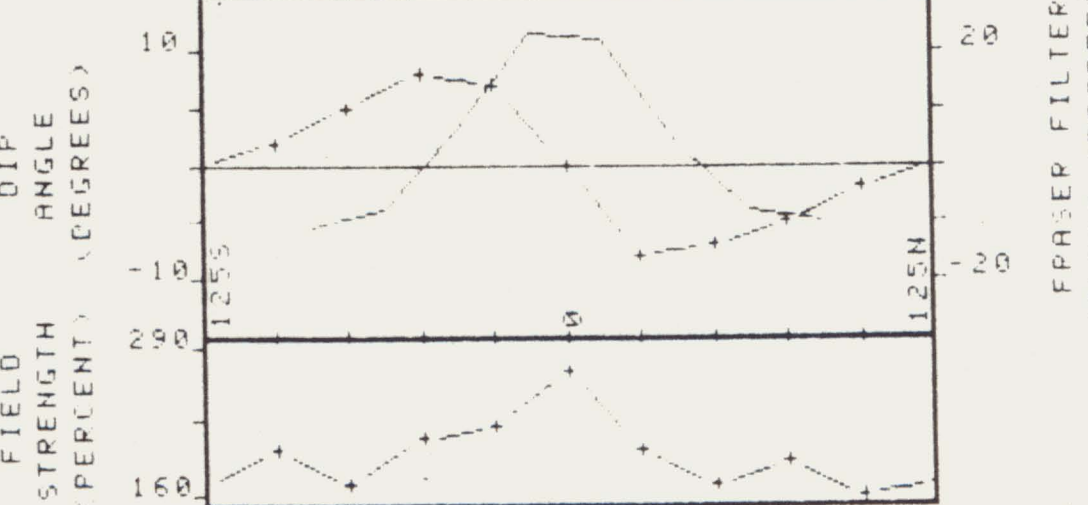

CONDUCTOR SYMBOLS

- DEFINITE
- PROBABLE
- POSSIBLE

15
PEAK AMPLITUDE
IN GAMMAS

DATE SURVEYED JULY 1980

APPROVED

Philip G. Hall
P. G. HALL
PROFESSIONAL
OF
BRITISH
COLUMBIA
ENGINEERS

DATE

Expiry Date: February 25, 1981

PHOENIX GEOPHYSICS LIMITED

VLF - ELECTROMAGNETIC SURVEY

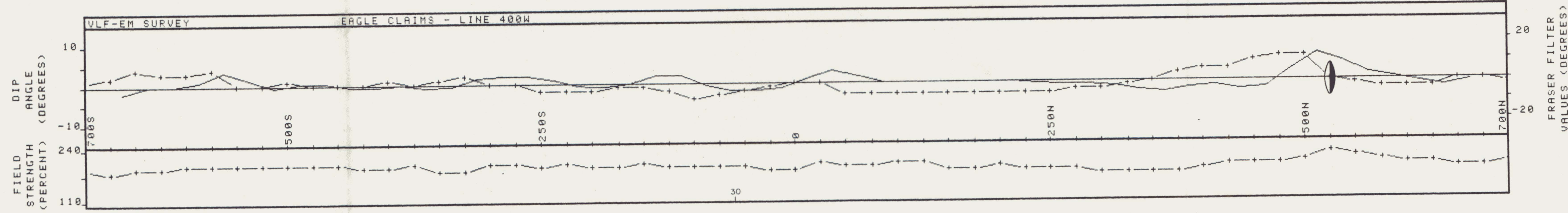
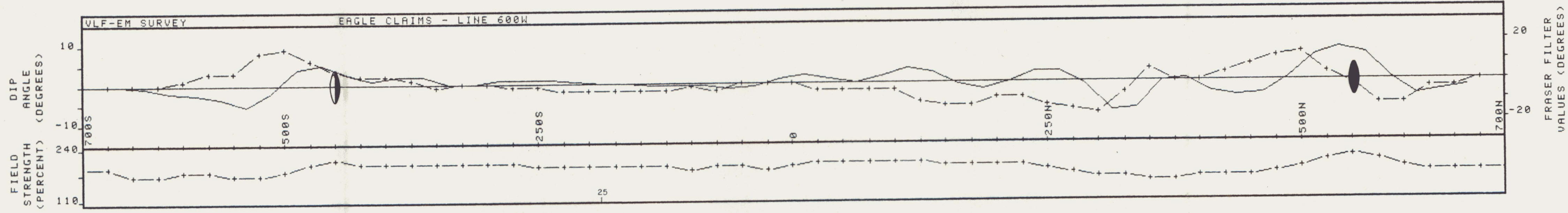
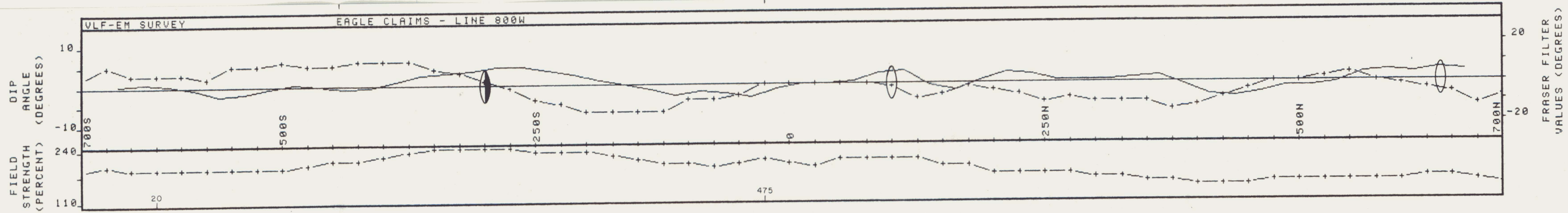

CORDILLERAN ENGINEERING LTD.

EAGLE CLAIM GROUP, WATSON LAKE M.D.

YUKON TERRITORY

LINE NO. - 200W

LINE NO. - 0

LINE NO. - 200E

VLF-EM SURVEY - LINE PROFILE

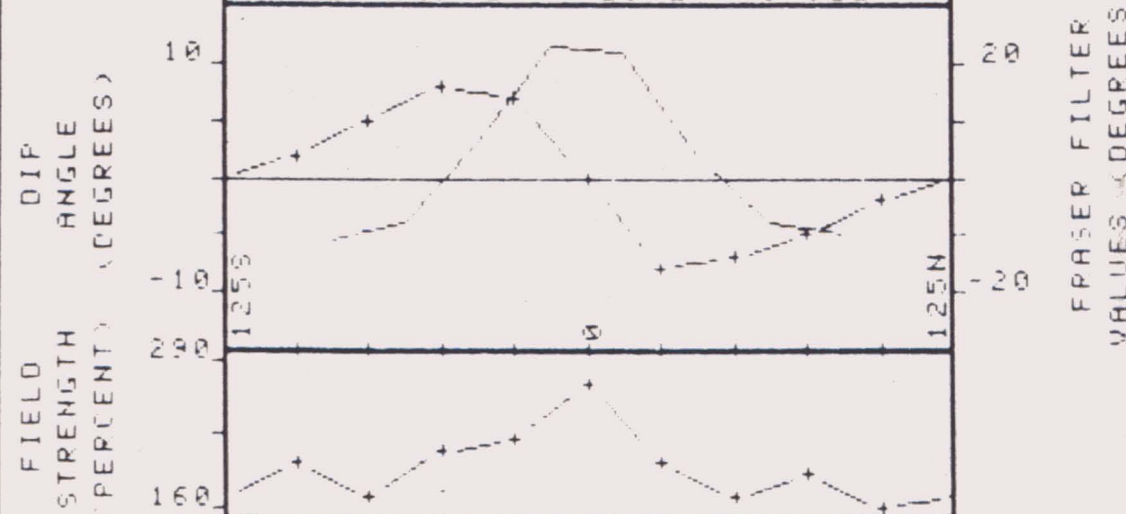

CONDUCTOR SYMBOLS

- DEFINITE
- PROBABLE
- POSSIBLE

15 PEAK AMPLITUDE IN GAMMAS

DATE SURVEYED JULY 1980

APPROVED

P. G. HALLOF
 P. G. HALLOF
 BRITISH COLUMBIA
 ENGINEER

DATE

Expiry Date: February 25, 1981

PHOENIX GEOPHYSICS LIMITED

VLF - ELECTROMAGNETIC SURVEY

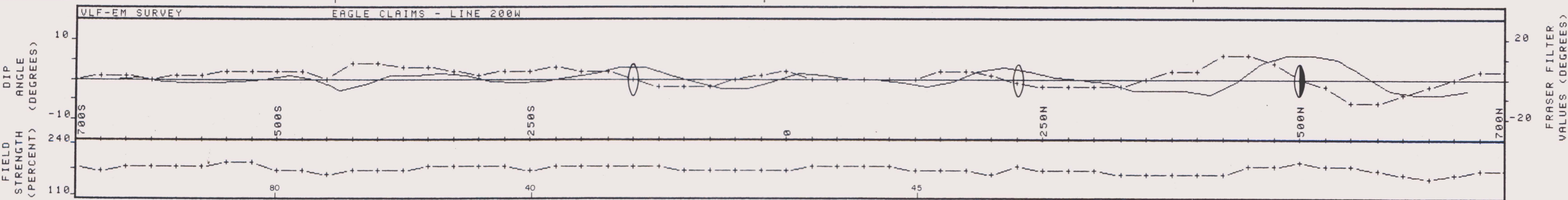

FRASER FILTER VALUES (DEGREES)

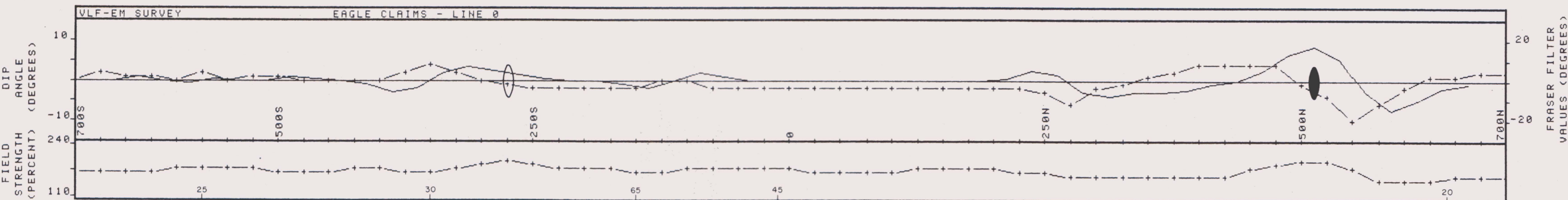

FRASER FILTER VALUES (DEGREES)

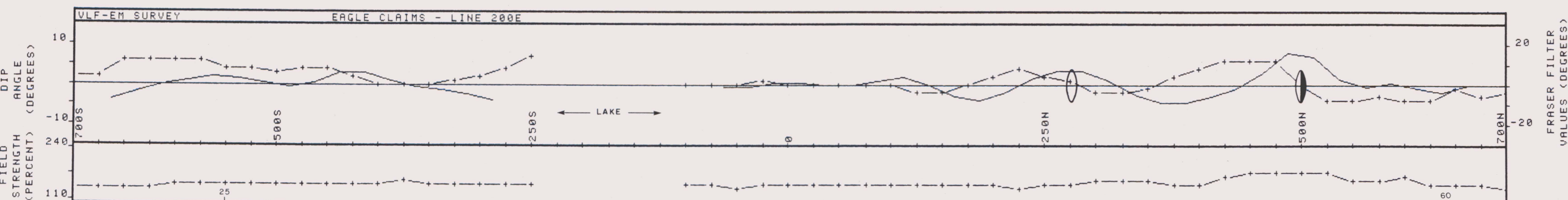

FRASER FILTER VALUES (DEGREES)

CORDILLERAN ENGINEERING LTD.

EAGLE CLAIM GROUP, WATSON LAKE M.D.

YUKON TERRITORY

LINE NO. - 390E

LINE NO. - 600E

LINE NO. - 800E

VLF-EM SURVEY - LINE PROFILE

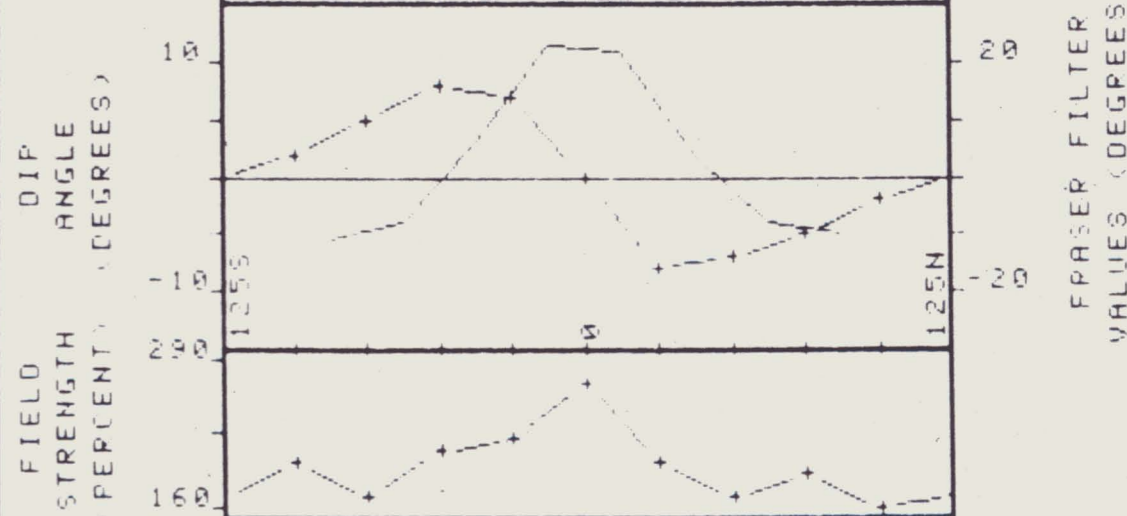

CONDUCTOR SYMBOLS

- DEFINITE
- PROBABLE
- POSSIBLE

15 PEAK AMPLITUDE IN GAMMAS

DATE SURVEYED JULY 1980

APPROVED

Philip G. Hall
 P. G. HALL
 BRITISH COLUMBIA
 ENGINEER

DATE

Expiry Date: February 25, 1981

PHOENIX GEOPHYSICS LIMITED

VLF - ELECTROMAGNETIC SURVEY

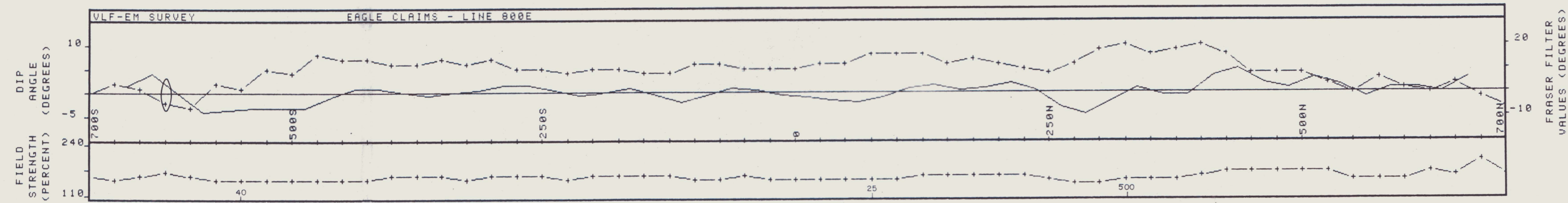
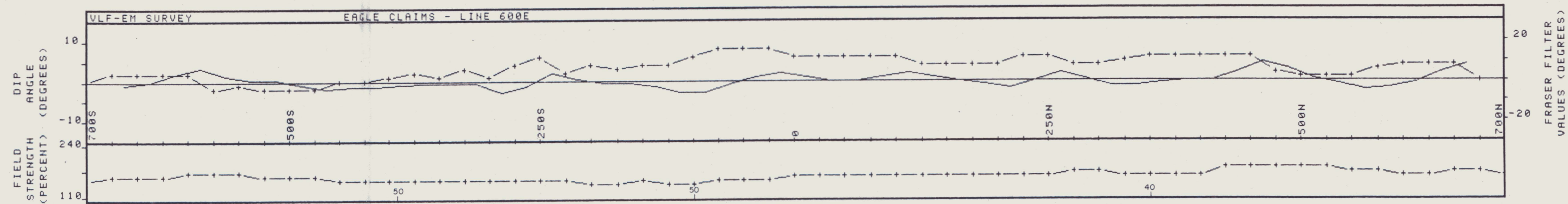
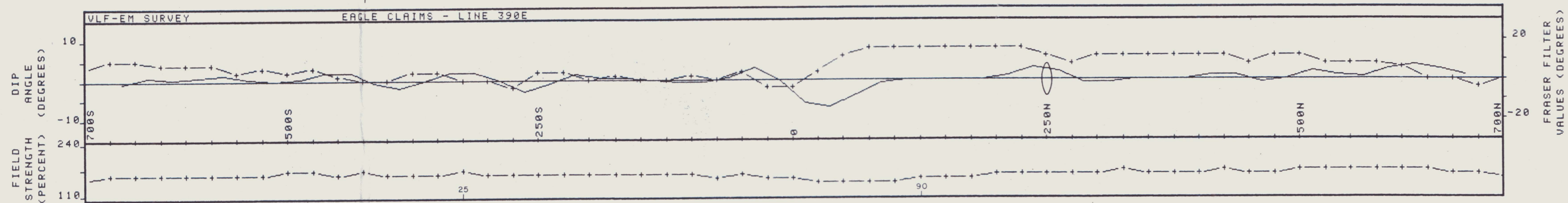

CORDILLERAN ENGINEERING LTD.

EAGLE CLAIM GROUP, WATSON LAKE M.D.

YUKON TERRITORY

LINE NO. - 1000E

LINE NO. - 1200E

LINE NO. - 1400E

VLF-EM SURVEY - LINE PROFILE

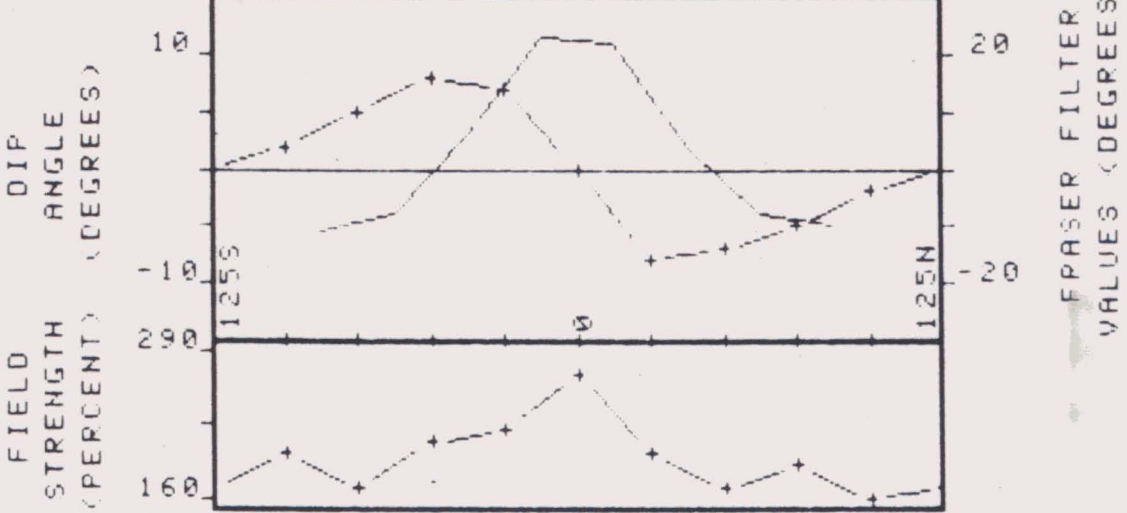

CONDUCTOR SYMBOLS

- DEFINITE
- PROBABLE
- POSSIBLE

15 PEAK AMPLITUDE IN GAMMAS

DATE SURVEYED JULY, 1980

APPROVED

P. G. HALLOF
 P. G. HALLOF
 BRITISH COLUMBIA
 ENGINEER

DATE

Expiry Date: February 25, 1981

PHOENIX GEOPHYSICS LIMITED

VLF - ELECTROMAGNETIC SURVEY

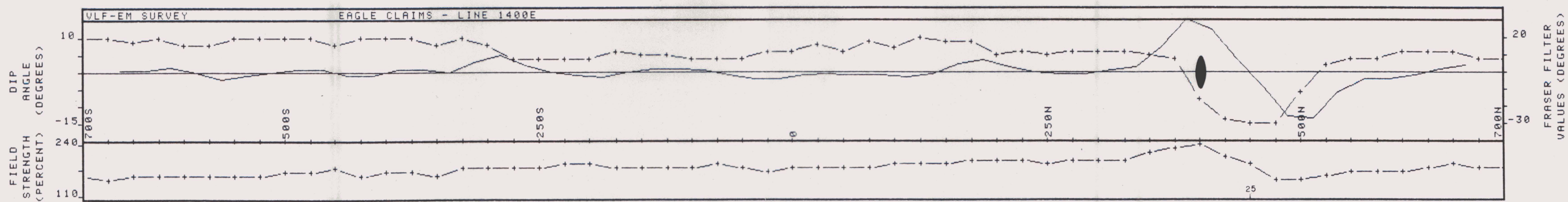
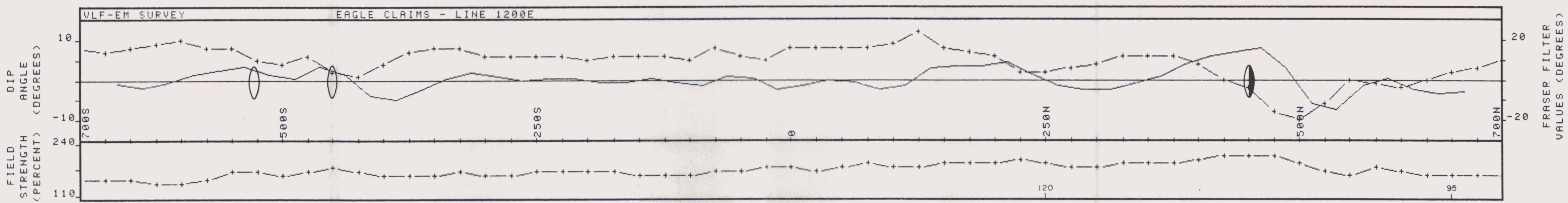
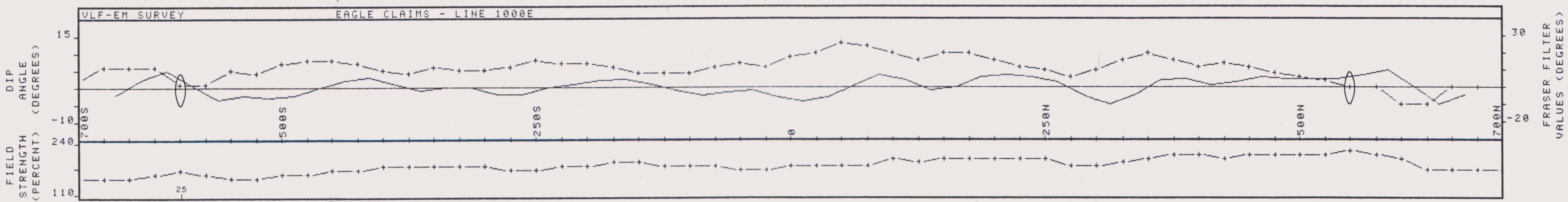

CORDILLERAN ENGINEERING LTD.

EAGLE CLAIM GROUP, WATSON LAKE M.D.

YUKON TERRITORY

LINE NO. - 1400W

LINE NO. - 1200W

LINE NO. - 1000W

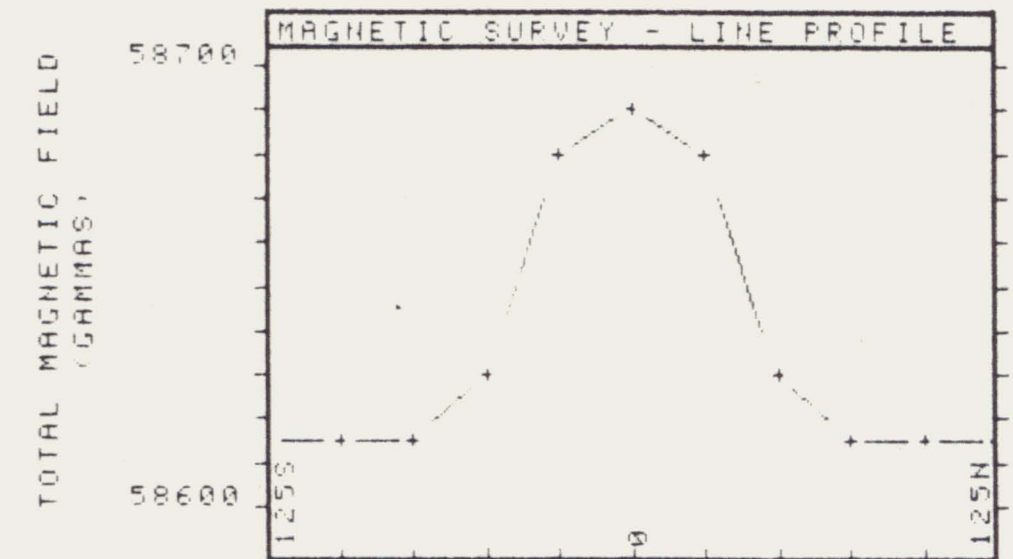

CONDUCTOR SYMBOLS

- DEFINITE
- PROBABLE
- POSSIBLE

DATE SURVEYED JULY 1980

APPROVED
Philip P. Haynes
 PHILIP P. HAYNES
 PROFESSIONAL ENGINEER

DATE 1/7/81

Expiry Date: February 25, 1981

PHOENIX GEOPHYSICS LIMITED

TOTAL MAGNETIC FIELD SURVEY

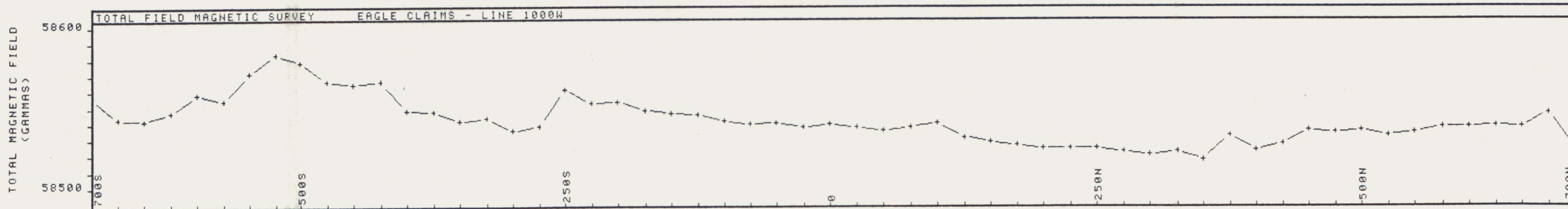
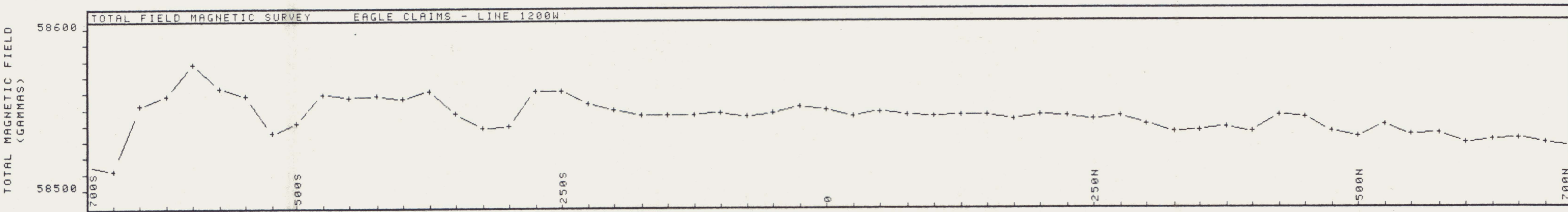
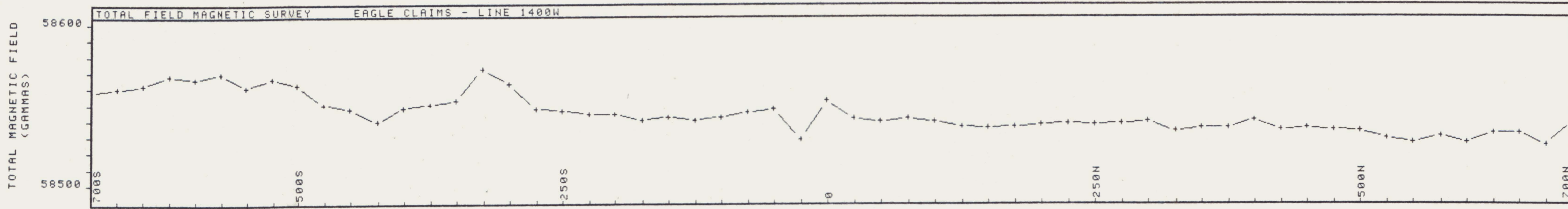

CORDILLERAN ENGINEERING LTD.

EAGLE CLAIM GROUP, WATSON LAKE M.D.

YUKON TERRITORY

LINE NO. - 800W

LINE NO. - 600W

LINE NO. - 400W

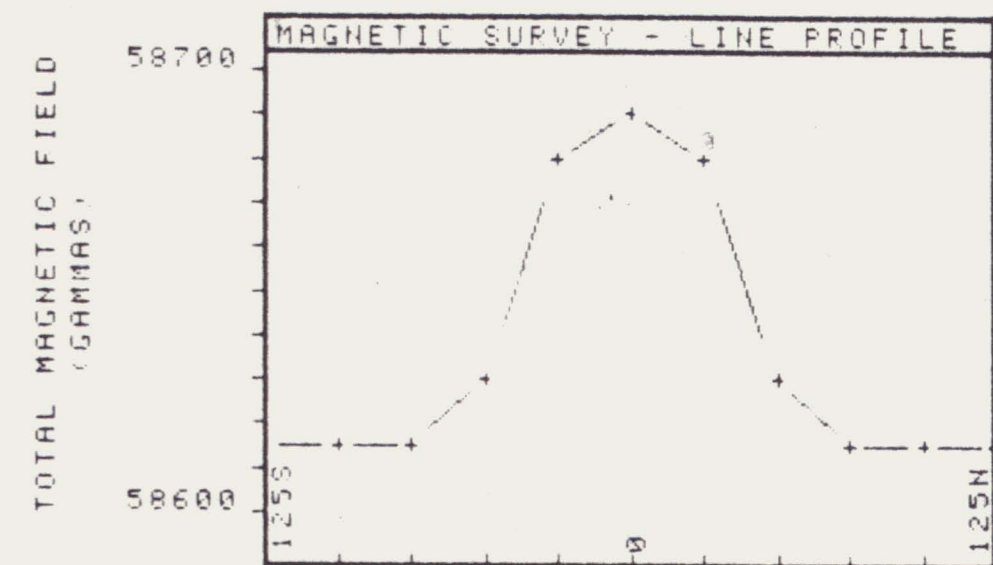

CONDUCTOR SYMBOLS

- DEFINITE
- ◐ PROBABLE
- POSSIBLE

DATE SURVEYED: JULY 1980

APPROVED

P. G. HALLOF
P. G. HALLOF

DATE 1/7/81

Expiry Date: February 25, 1981

PHOENIX GEOPHYSICS LIMITED

TOTAL MAGNETIC FIELD SURVEY

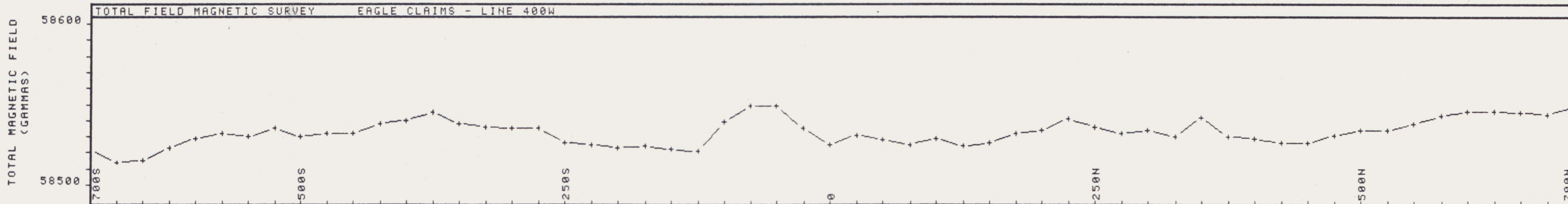
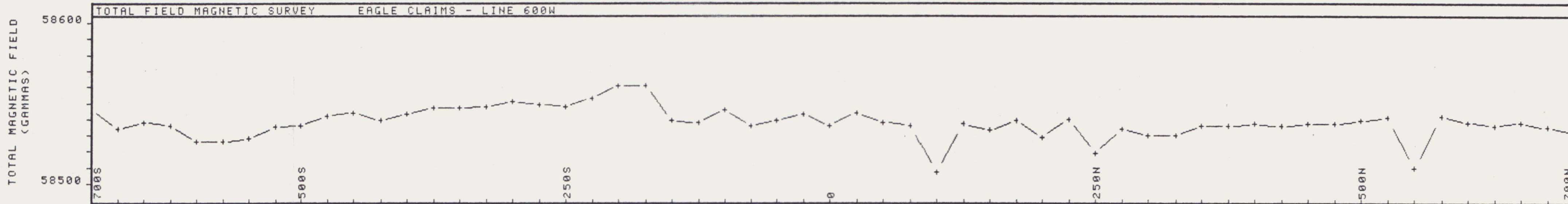
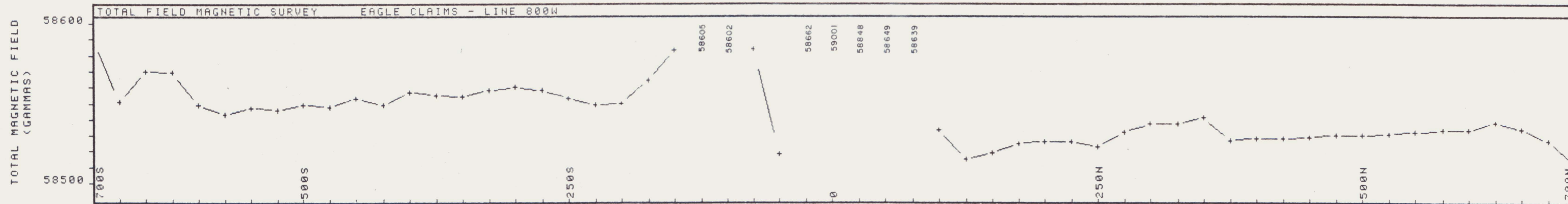

CORDILLERAN ENGINEERING LTD.

EAGLE CLAIM GROUP, WATSON LAKE M.D.

YUKON TERRITORY

LINE NO. - 200W

LINE NO. - 0

LINE NO. - 200E

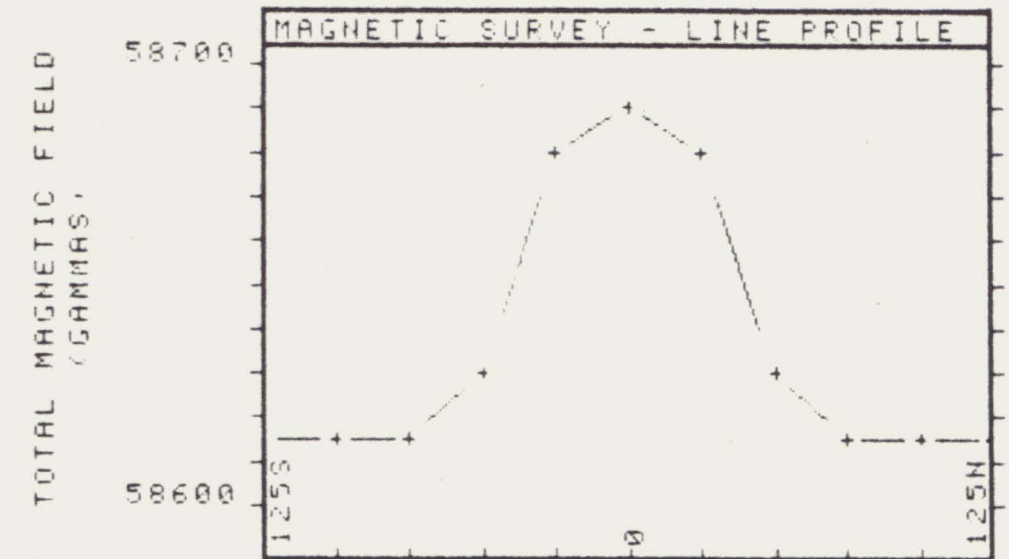

CONDUCTOR SYMBOLS

- DEFINITE
- PROBABLE
- POSSIBLE

DATE SURVEYED 17/7/80

APPROVED

Philip S. Hall
 P. S. HALL
 BRITISH COLUMBIA
 ENGINEER

DATE

Expiry Date: February 25, 1981

PHOENIX GEOPHYSICS LIMITED

TOTAL MAGNETIC FIELD SURVEY

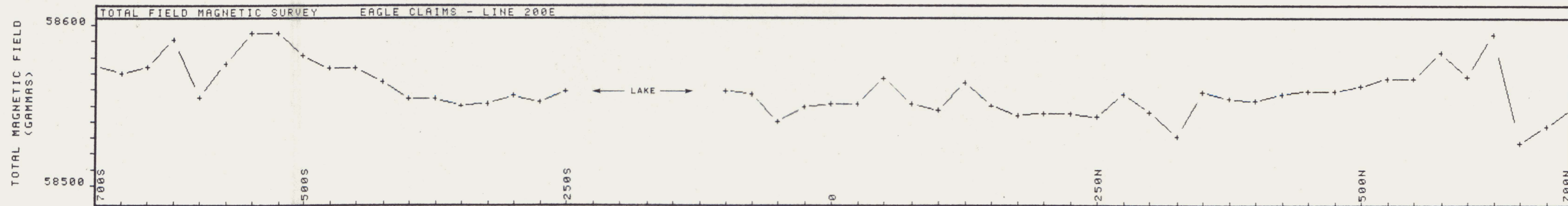
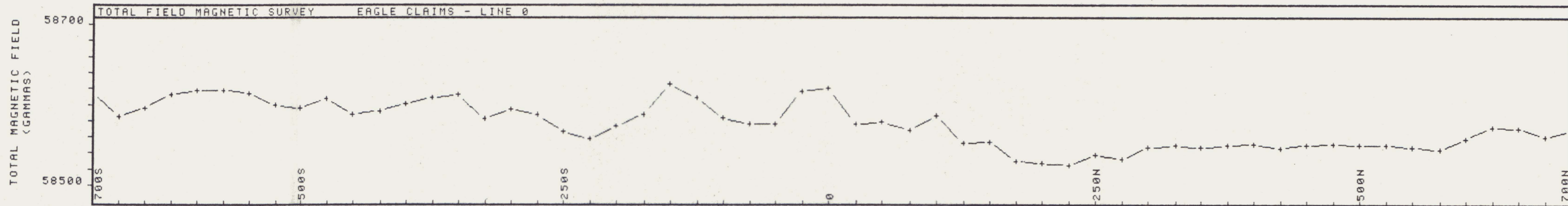
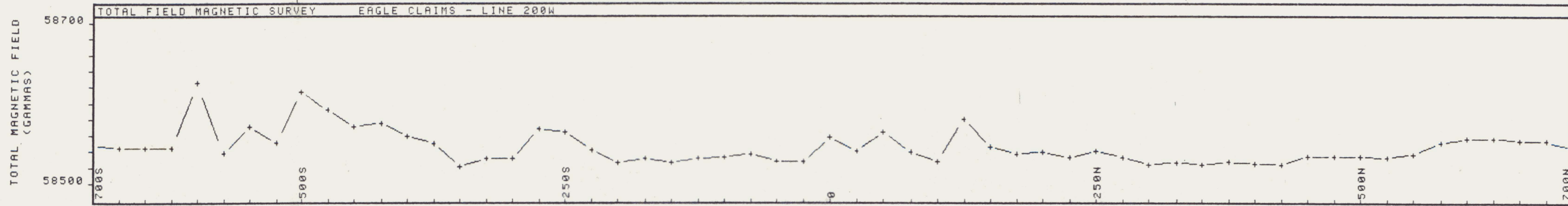

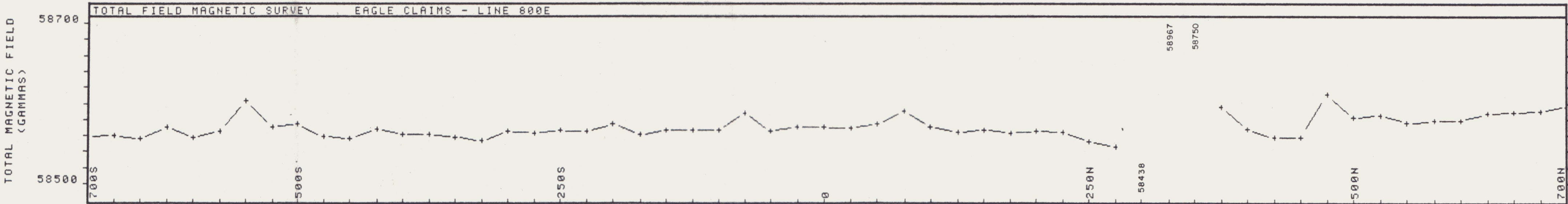
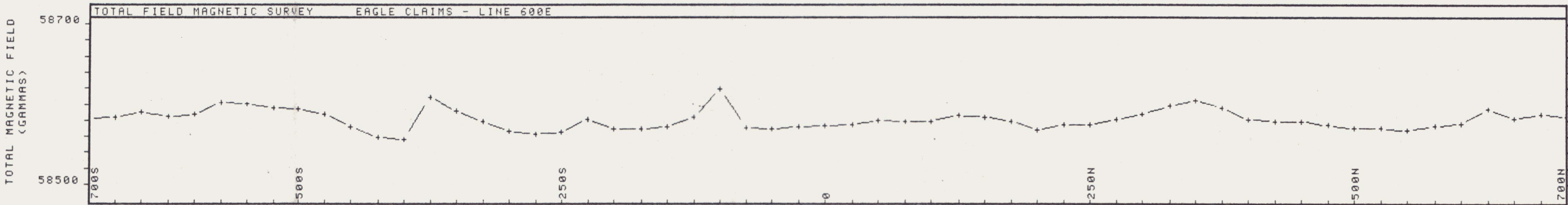
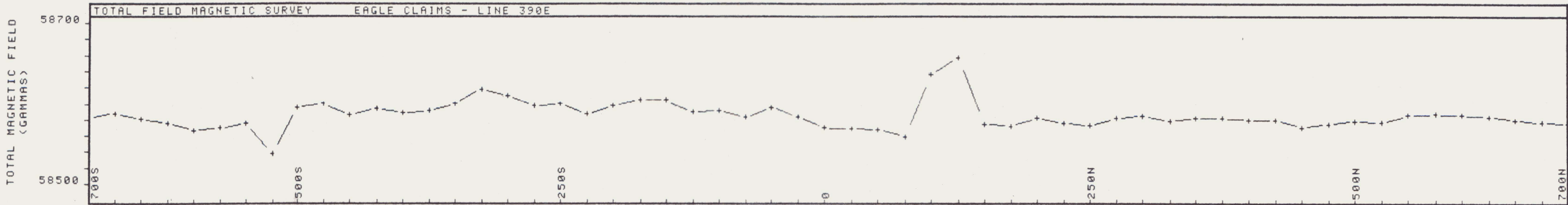

DWG. NO. - M. -5240-4

CORDILLERAN ENGINEERING LTD.

EAGLE CLAIM GROUP, WATSON LAKE M.D.

YUKON TERRITORY

LINE NO. - 390E
 LINE NO. - 600E
 LINE NO. - 800E

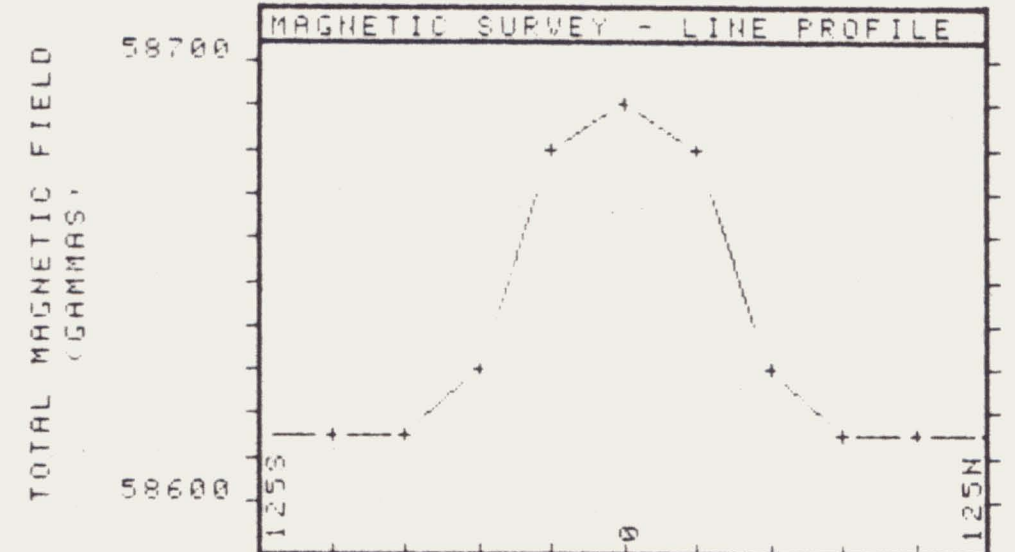

CONDUCTOR SYMBOLS

- DEFINITE
- ◐ PROBABLE
- POSSIBLE

DATE SURVEYED JULY 1980

APPROVED

P. G. HALYOF
 P. G. HALYOF
 BRITISH COLUMBIA
 ENGINEER

DATE 1/7/81

Expiry Date: February 25, 1981

PHOENIX GEOPHYSICS LIMITED

TOTAL MAGNETIC FIELD SURVEY

CORDILLERAN ENGINEERING LTD.

EAGLE CLAIM GROUP, WATSON LAKE M.D.

YUKON TERRITORY

LINE NO. - 1000E

LINE NO. - 1200E

LINE NO. - 1400E

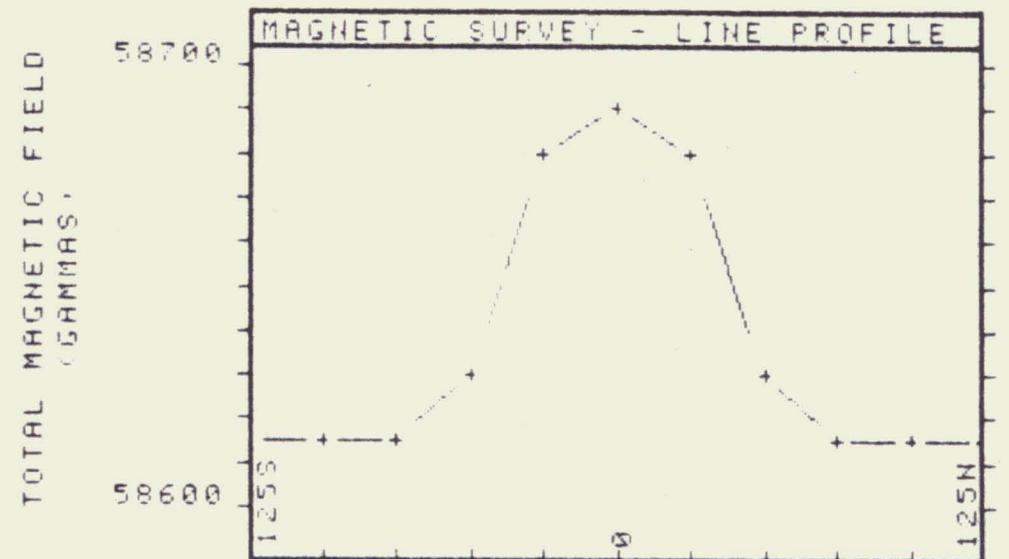

CONDUCTOR SYMBOLS

- DEFINITE
- PROBABLE
- POSSIBLE

DATE SURVEYED 17 JULY 1980

APPROVED

P. G. HALLOP
 P. G. HALLOP
 BRITISH COLUMBIA
 ENGINEER

DATE

Expiry Date: February 25, 1981

PHOENIX GEOPHYSICS LIMITED

TOTAL MAGNETIC FIELD SURVEY

