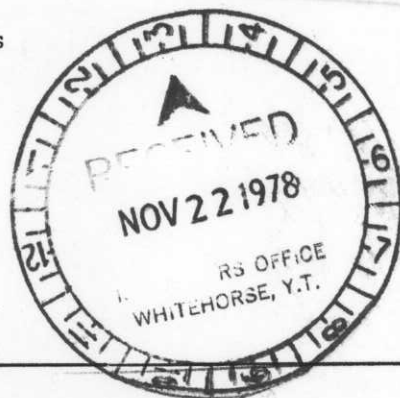

TABLE OF CONTENTS

<u>Part A:</u>	Notes on theory and field procedure	8 pages	
<u>Part B:</u>	Report	15 pages	<u>Page</u>
1.	Introduction		1
2.	Description of the Claims		2
3.	Presentation of Results		2
4.	Description of Geology		5
5.	Discussion of Results		5
6.	Summary and Conclusions		9
7.	Assessment Details		11
8.	Statement of Cost		12
9.	Certificate - A.W. Mullan		13
10.	Certificate - P.C. Hallof		14
11.	Certificate - J. Marsh		15
12.	Equipment Specifications - IPT-1 - IPV-1		
<u>Part C:</u>	Illustrations	25 pieces	
	Plan Maps (in pockets)		Dwg. I.P.P. 4041 & 4042
	IP Data Plots		Dwg. IP 5115-1 Dwg. IP 5116-1 to -14 Dwg. IP 5117-1 to -8



090407

This report has been examined by the
 Geological Survey and is recom-
 mended to be considered
 as representation work in the amount of

\$ See Geochem Dept
4 Jan 79

Resident Geologist or
 Resident Mining Engineer

Considered as representation work under
 Section 53 (4) Yukon Quartz Mining Act.

B. R. BAXTER
 Supervising Mining Recorder

Commissioner of Yukon Territory



TABLE OF CONTENTS

Part A: Notes on theory and field procedures

Part B: Report

1. Introduction
2. Description of the Claims
3. Presentational Results
4. Description of Geology
5. Discussion of Results
6. Summary and Conclusions
7. Assessment Details
8. Treatment of Case
9. Certificate - A.W. Halliday
10. Certificate - F.C. Halliday
11. Certificate - J. Marsh
12. Equipment Specifications - IPT-1 - IPT-1

25 pieces
 Dwg. I.R.V. 4001 & 4042
 Dwg. IP 5115-1
 Dwg. IP 5115-1 co -1A
 Dwg. IP 5117-1 co -8

090407

PHOENIX GEOPHYSICS LIMITED

NOTES ON THE THEORY, METHOD OF FIELD OPERATION, AND PRESENTATION OF DATA FOR THE INDUCED POLARIZATION METHOD

Induced Polarization as a geophysical measurement refers to the blocking action or polarization of metallic or electronic conductors in a medium of ionic solution conduction.

This electro-chemical phenomenon occurs wherever electrical current is passed through an area which contains metallic minerals such as base metal sulphides. Normally, when current is passed through the ground, as in resistivity measurements, all of the conduction takes place through ions present in the water content of the rock, or soil, i.e. by ionic conduction. This is because almost all minerals have a much higher specific resistivity than ground water, The group of minerals commonly described as "metallic", however, have specific resistivities much lower than ground waters. The induced polarization effect takes place at those interfaces where the mode of conduction changes from ionic in the solutions filling the interstices of the rock to electronic in the metallic minerals present

in the rock.

The blocking action or induced polarization mentioned above, which depends upon the chemical energies necessary to allow the ions to give up or receive electrons from the metallic surface, increases with the time that a d.c. current is allowed to flow through the rock; i.e. as ions pile up against the metallic interface the resistance to current flow increases. Eventually, there is enough polarization in the form of excess ions at the interfaces, to appreciably reduce the amount of current flow through the metallic particle. This polarization takes place at each of the infinite number of solution-metal interfaces in a mineralized rock.

When the d.c. voltage used to create this d.c. current flow is cut off, the Coulomb forces between the charged ions forming the polarization cause them to return to their normal position. This movement of charge creates a small current flow which can be measured on the surface of the ground as a decaying potential difference.

From an alternate viewpoint it can be seen that if the direction of the current through the system is reversed repeatedly before the polarization occurs, the effective resistivity of the system as a whole will change as the frequency of the switching is changed. This is a consequence of the fact that the amount of current flowing through each metallic interface depends upon the length of time that current has been passing through it in one direction.

The values of the per cent frequency effect or F.E. are a measurement of the polarization in the rock mass. However, since the measurement of the degree of polarization is related to the apparent resistivity of the rock mass it is found that the metal factor values or M.F. are the most useful values in determining the amount of polarization present in the rock mass. The MF values are obtained by normalizing the F.E. values for varying resistivities.

The induced polarization measurement is perhaps the most powerful geophysical method for the direct detection of metallic sulphide mineralization, even when this mineralization is of very low concentration. The lower limit of volume per cent sulphide necessary to produce a recognizable IP anomaly will vary with the geometry and geologic environment of the source, and the method of executing the survey. However, sulphide mineralization of less than one per cent by volume has been detected by the IP method under proper geological conditions.

The greatest application of the IP method has been in the search for disseminated metallic sulphides of less than 20% by volume. However, it has also been used successfully in the search for massive sulphides in situations where, due to source geometry, depth of source, or low resistivity of surface layer, the EM method cannot be successfully applied. The ability to differentiate ionic conductors, such as water filled shear zones, makes the IP method a useful tool in checking EM

anomalies which are suspected of being due to these causes.

In normal field applications the IP method does not differentiate between the economically important metallic minerals such as chalcopyrite, chalcocite, molybdenite, galena, etc., and the other metallic minerals such as pyrite. The induced polarization effect is due to the total of all electronic conducting minerals in the rock mass. Other electronic conducting materials which can produce an IP response are magnetite, pyrolusite, graphite, and some forms of hematite.

In the field procedure, measurements on the surface are made in a way that allows the effects of lateral changes in the properties of the ground to be separated from the effects of vertical changes in the properties. Current is applied to the ground at two points in distance (X) apart. The potentials are measured at two points (X) feet apart, in line with the current electrodes is an integer number (n) times the basic distance (X).

The measurements are made along a surveyed line, with a constant distance (nX) between the nearest current and potential electrodes. In most surveys, several traverses are made with various values of (n); i.e. (n) = 1,2,3,4, etc. The kind of survey required (detailed or reconnaissance) decides the number of values of (n) used.

In plotting the results, the values of apparent resistivity, apparent per cent frequency effect, and the apparent metal factor

measured for each set of electrode positions are plotted at the intersection of grid lines, one from the center point of the current electrodes and the other from the center point of the potential electrodes. (See Figure A.) The resistivity values are plotted at the top of the data profile, above the metal factor values. On a third line, below the metal factor values, are plotted the values of the percent frequency effect. The lateral displacement of a given value is determined by the location along the survey line of the center point between the current and potential electrodes. The distance of the value from the line is determined by the distance (nX) between the current and potential electrodes when the measurement was made.

The separation between sender and receiver electrodes is only one factor which determines the depth to which the ground is being sampled in any particular measurement. The plots then, when contoured, are not section maps of the electrical properties of the ground under the survey line. The interpretation of the results from any given survey must be carried out using the combined experience gained from field results, model study results and the theoretical investigations. The position of the electrodes when anomalous values are measured is important in the interpretation.

In the field procedure, the interval over which the potential differences are measured is the same as the interval over which the electrodes are moved after a series of potential readings has been made.

One of the advantages of the induced polarization method is that the same equipment can be used for both detailed and reconnaissance surveys merely by changing the distance (X) over which the electrodes are moved each time. In the past, intervals have been used ranging from 25 feet to 2000 feet for (X). In each case, the decision as to the distance (X) and the values of (n) to be used is largely determined by the expected size of the mineral deposit being sought, the size of the expected anomaly and the speed with which it is desired to progress.

The diagram in Figure A demonstrates the method used in plotting the results. Each value of the apparent resistivity, apparent metal factor, and apparent per cent frequency effect is plotted and identified by the position of the four electrodes when the measurement was made. It can be seen that the values measured for the larger values of (n) are plotted farther from the line indicating that the thickness of the layer of the earth that is being tested is greater than for the smaller values of (n); i.e. the depth of the measurement is increased.

The IP measurement is basically obtained by measuring the difference in potential or voltage (ΔV) obtained at two operating frequencies. The voltage is the product of the current through the ground and the apparent resistivity of the ground. Therefore in field situations where the current is very low due to poor electrode contact, or the apparent resistivity is very low, or a combination of the two effects; the value of (ΔV) the change in potential will be too small to be measurable. The symbol "TL" on the data plots indicates this situation.

In some situations spurious noise, either man made or natural, will render it impossible to obtain a reading. The symbol "N" on the data plots indicates a station at which it is too noisy to record a reading. If a reading can be obtained, but for reasons of noise there is some doubt as to its accuracy, the reading is bracketed in the data plot ().

In certain situations negative values of Apparent Frequency Effect are recorded. This may be due to the geologic environment or spurious electrical effects. The actual negative frequency effect value recorded is indicated on the data plot, however, the symbol "NEG" is indicated for the corresponding value of Apparent Metal Factor. In contouring negative values the contour lines are indicated to the nearest positive value in the immediate vicinity of the negative value.

The symbol "NR" indicates that for some reason the operator did not attempt to record a reading although normal survey procedures would suggest that one was required. This may be due to inaccessible topography or other similar reasons. Any symbol other than those discussed above is unique to a particular situation and is described within the body of the report.

PHOENIX GEOPHYSICS LIMITED.

METHOD USED IN PLOTTING DIPOLE-DIPOLE INDUCED POLARIZATION AND RESISTIVITY RESULTS

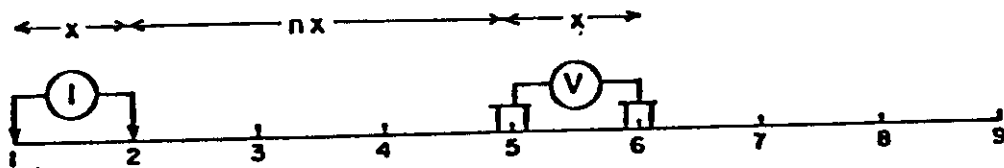

Stations on line

x = Electrode spread length
 n = Electrode separation

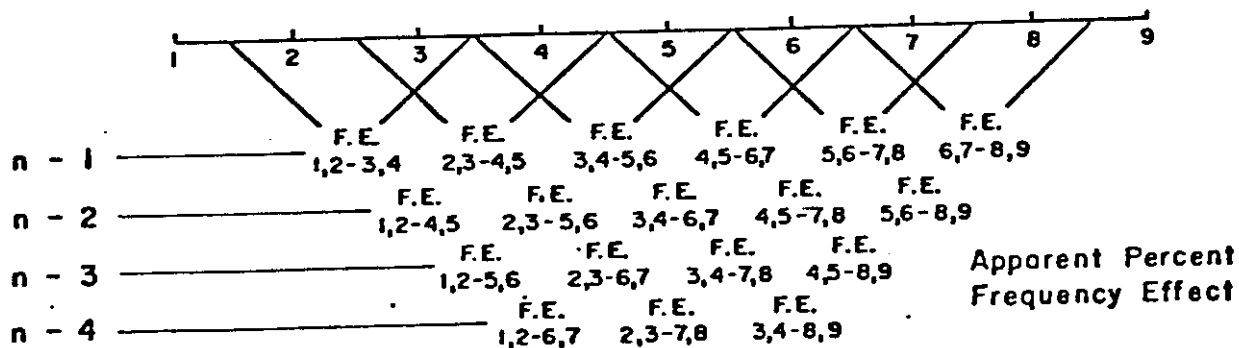
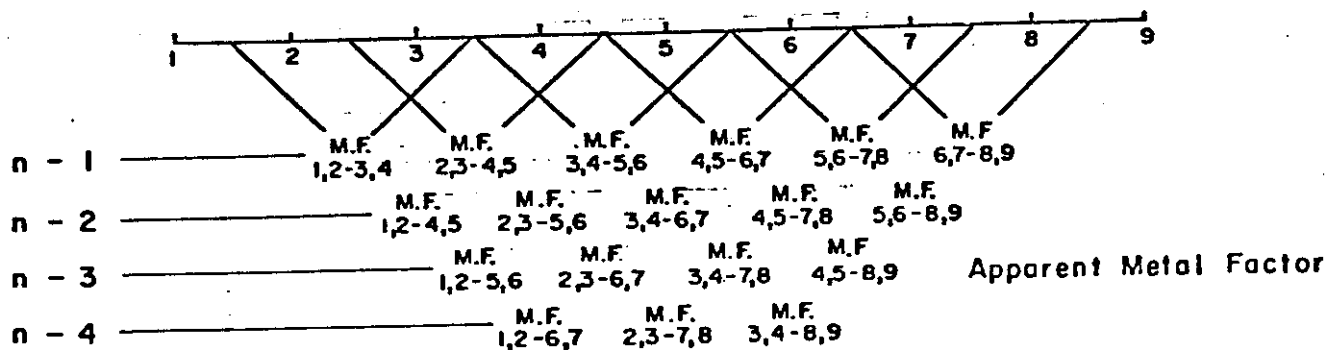
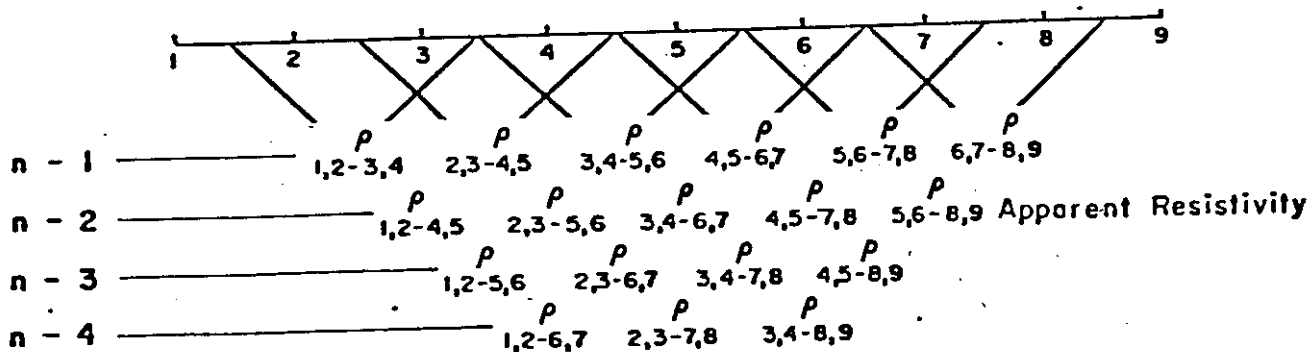

Fig. A

PHOENIX GEOPHYSICS LIMITED

REPORT ON THE
INDUCED POLARIZATION
AND RESISTIVITY SURVEY
LUCKY JOE CLAIMS, GRIDS 1, 2 & 3
N.T.S. 115/0 - 11, 12
YUKON TERRITORY
FOR
RIO TINTO CANADIAN EXPLORATION LTD.

1. INTRODUCTION

An Induced Polarization and Resistivity survey was carried out for Rio Tinto Canadian Exploration Ltd., on the Lucky Joe Claim Group. The claims are located about 33 miles south of Dawson City in the Yukon Territory. The centre of the claims is positioned at about $139^{\circ}30'$ west longitude and $63^{\circ}35'$ north latitude.

Access to the property is by boat up the Yukon River or more conveniently by helicopter from Dawson City.

The purpose of the survey was to delineate zones of metallic sulphide mineralization which have been found to contain interesting associated copper values in the Grid #1 Area.

Field work was carried out under the direction of Crew Leader,

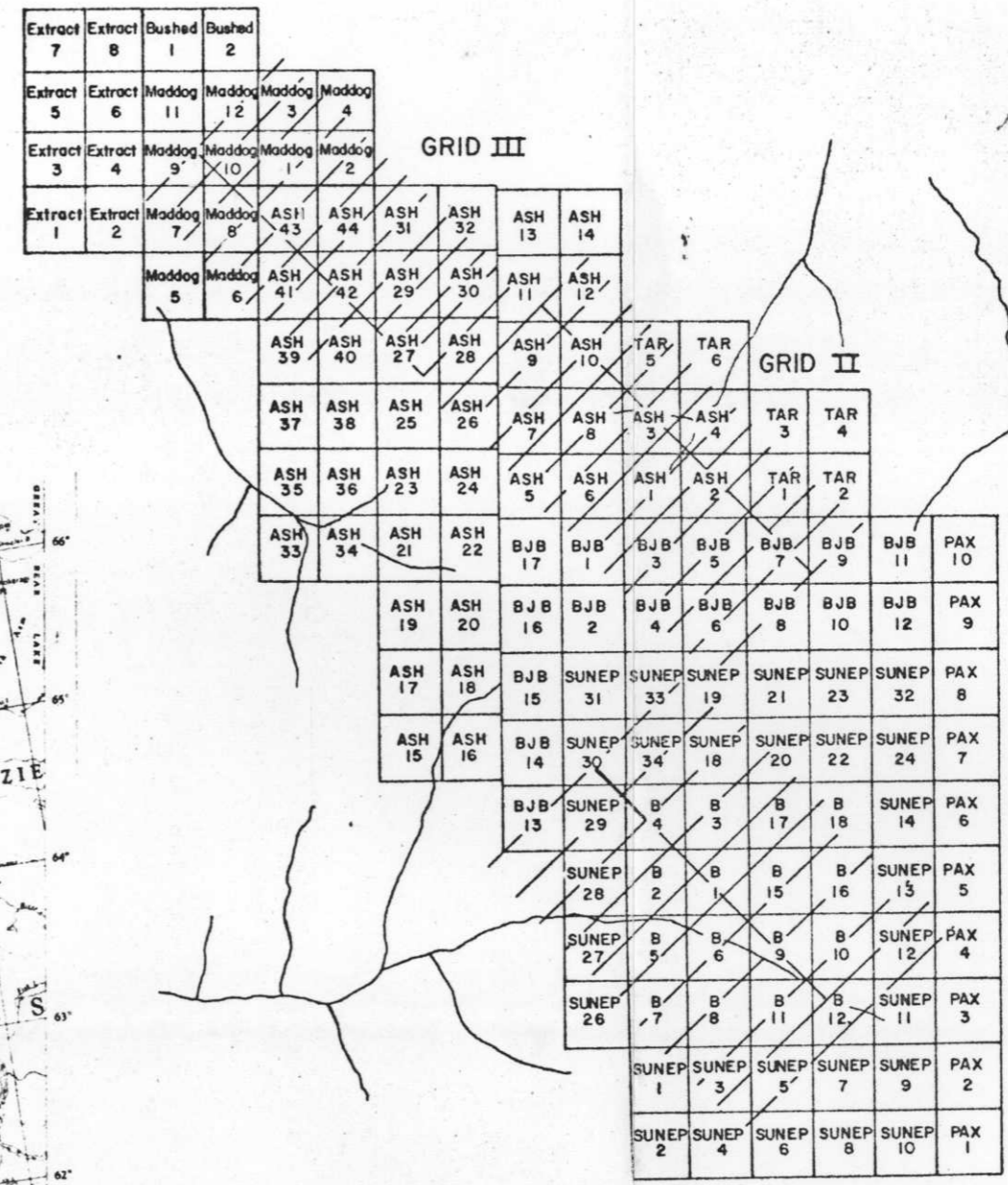
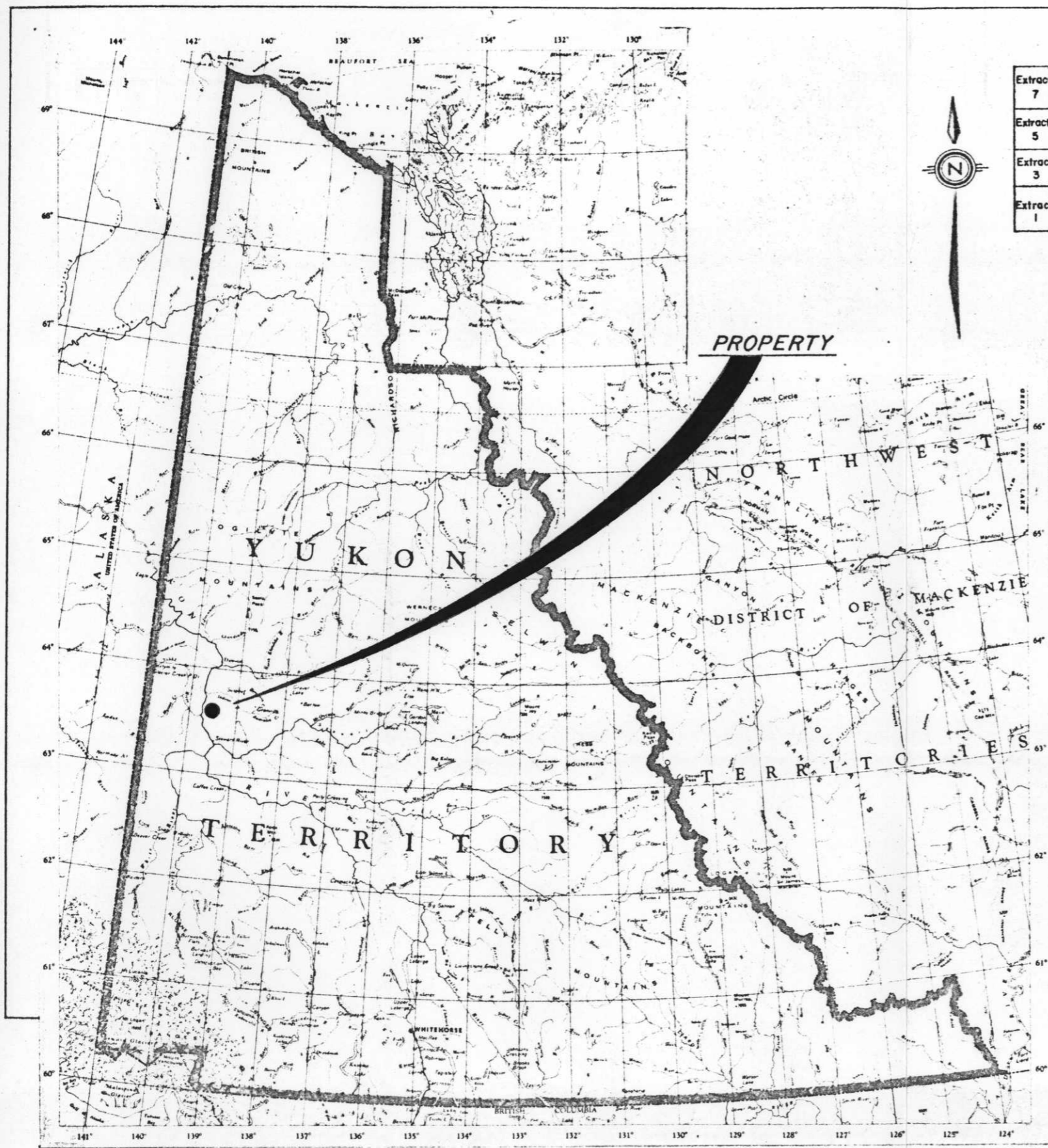

SCALE 1:50,000

N.T.S. 1150/11,12

RIO TINTO CANADIAN EXPLORATION LTD.		
LUCKY JOE OPTION		
PROPERTY LOCATION		
JULY 1976	J.M. /y.m.	DWG. L.- 6385

SCALE One Inch = 80 Miles

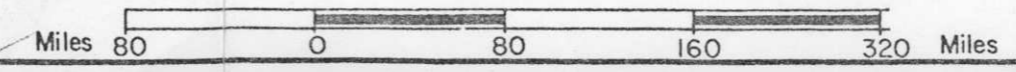

John Marsh, (a certificate of qualification is appended to this report).

Field work was carried out during the latter part of May and early June, 1978. A Phoenix frequency domain IP system Model IPT-1, IPV-1 was used for the survey operating at 0.3 and 5.0 hertz.

2. DESCRIPTION OF THE CLAIMS

The Lucky Joe option consists of the following mining claims:

LIST OF CLAIMS

<u>Claim Names</u>	<u>Tag Numbers</u>	<u>Anniversary</u>
B 1 - 12	Y56956-Y56967	10 Nov. 1982
B 15 - 18	Y56970-Y56973	10 Nov. 1982
BJB 1 - 8	Y99779-Y99886	10 Nov. 1982
BJB 9 - 17	Y99868-Y99876	10 Nov. 1982
SUNEP 1 - 14	Y99745-Y99758	10 Nov. 1982
SUNEP 18 - 24	Y99759-Y99765	10 Nov. 1982
SUNEP 26 - 34	Y99766-Y99774	10 Nov. 1982
ASH 1 - 44	Y99883-Y99926	10 Nov. 1982
PAX 1 - 10	Y99927-Y99936	10 Nov. 1982
TAR 1 - 6	YA29800-YA29805	5 June 1979
MAD DOG 1 - 12	YA29806-YA29817	5 June 1979
N.B. The following 10 Claims were staked after completion of the IP survey.		
EXTRACT 1 - 8	YA31216-YA31223	4 July 1979
BUSHED 1 - 2	YA31224-YA31225	4 July 1979

3. PRESENTATION OF RESULTS

The Induced Polarization and Resistivity survey results are shown on the following data plots in the manner described in the notes preceding this report.

<u>Line</u>	<u>Electrode Interval</u>	<u>Dwg. No.</u>
<u>GRID #1</u>		
0	100 M	IP 5115-1
<u>GRID #2</u>		
14W	100 M	IP 5116-1
12W	100 M	IP 5116-2
10W	100 M	IP 5116-3
8W	100 M	IP 5116-4
6W	100 M	IP 5116-5
4W	100 M	IP 5116-6
2W	100 M	IP 5116-7
0+00	100 M	IP 5116-8
2E	100 M	IP 5116-9
4E	100 M	IP 5116-10
6E	100 M	IP 5116-11
8E	100 M	IP 5116-12
10E	100 M	IP 5116-13
12E	100 M	IP 5116-14
<u>GRID #3</u>		
6W	100 M	IP 5117-1
4W	100 M	IP 5117-2
2W	100 M	IP 5117-3
0+00	100 M	IP 5117-4
2E	100 M	IP 5117-5
4E	100 M	IP 5117-6

<u>Line</u>	<u>Electrode Interval</u>	<u>Dwg. No.</u>
6E	100 M	IP 5117-7
8E	100 M	IP 5117-8

Also enclosed with this report are Dwg. I.P.P. 4041 and Dwg. I.P.P. 4042, plan maps of the Lucky Joe Grid No.2 and Lucky Joe Grid No.3, at a scale of 1:5000 metric. The definite, probable and possible Induced Polarization anomalies are indicated by bars, in the manner shown on the legend, on these plan maps as well as on the data plots. These bars represent the surface projection of the anomalous zones as interpreted from the location of the transmitter and receiver electrodes when the anomalous values were measured.

Since the Induced Polarization measurement is essentially an averaging process, as are all potential methods, it is frequently difficult to exactly pinpoint the source of an anomaly. Certainly, no anomaly can be located with more accuracy than the electrode interval length; i.e. when using 100 M electrode intervals the position of a narrow sulphide body can only be determined to lie between two stations 100 M apart. In order to definitely locate, and fully evaluate, a narrow, shallow source it is necessary to use shorter electrode intervals. In order to locate sources at some depth, larger electrode intervals must be used, with a corresponding increase in the uncertainties of location. Therefore, while the centre of the indicated anomaly probably corresponds fairly well with source, the length of the indicated anomaly along the line should not be taken to represent the exact edges of the anomalous material.

The claim, topographic and grid information shown on Dwg. I.P.P. 4041 and Dwg. I.P.P. 4042, has been taken from maps made available by the staff of Rio Tinto Canadian Exploration Ltd.

4. DESCRIPTION OF GEOLOGY

The area was mapped at a scale of 1 inch to 4 miles by the G.S.C. in 1934 and 1935 (G.S.C. Map 711A; Bostock, 1942). This work shows the property to be situated over a north-south trending belt of Yukon Group gneiss and schist, sandwiched between two large bodies of gneissic granite. Outcrop and float noted during the current survey suggest this work to be reasonably accurate.

5. DISCUSSION OF RESULTS

Resistivity levels were found to be moderate to high under the three grids surveyed. Most Induced Polarization (IP) anomalies correlate with a moderate resistivity low.

A magnetometer survey was carried out by Riocanex over the three grids. Grid #1 shows a 1000 - 2000 gamma anomaly immediately south of the IP anomaly. The magnetic picture was essentially flat under Grid #2. Grid #3 shows a weak to moderate magnetic anomaly correlating with part of the Zone "A" IP anomaly. Since Zone "A" is more extensive than the magnetic anomaly, the IP source of this zone must also include non-magnetic metallic mineralization.

a) Grid #1

A time domain IP survey and a diamond drilling program was carried out within Grid #1 in 1975. Line 0+00 was resurveyed by Phoenix in order to provide a basis for comparison of the time domain and frequency domain IP data. Additionally, three diamond drill holes provide information

concerning the mineralization in the vicinity of this IP anomaly.

The comparison shows a considerable difference in resistivity level between the two surveys. The Phoenix levels are from 2.2 to 6.0 times higher than those recorded by Riocanex. The central section of Line 0+00 between 2+00N and 4+00S shows a reasonably consistent difference averaging about 2.45. The north section of the line displays greater differences ranging from 3.3 to 6.0 times. The resistivity pattern is similar except for the north section. A report from the field suggests that there is a problem with line location at the north end with regard to the two surveys. This could account for the poor correlation with resistivity levels.

The chargeabilities recorded by the Riocanex survey average 6.9 times higher than the percentage frequency effects (P.F.E.) recorded by Phoenix. The relationship of chargeability to P.F.E. is a function both of the integration period and frequency difference. The important consideration is the ratio of anomaly magnitude to background value. In general, the two methods compare favourably in this respect, and the patterns are quite similar.

The mineralized section outlined by the diamond drilling lies within the area of highest IP effects. The best copper values occur near the top of the mineralized section. The greatest concentration of sulphides occurs just north of, and stratigraphically below, this copper zone. However, there is little difference in magnitude of the IP effect within the anomaly. This probably results from the moderate depth to the top of this anomalous source.

b) Grid #2

The copper-bearing biotite, muscovite schist horizon, shows a dip

variation from about 45° under Grid #1 to an undulating, near-horizontal attitude under Grid #2 and Grid #3. This condition, combined with moderate local relief, results in depth variations to the target host formation. Locally, younger quartzite, gneiss and schist overlie the copper-bearing biotite, muscovite schist. The IP survey outlines apparent parallel anomalous zones, separated by weaker or blank sections. In fact the metallic mineralization in the host formation may be continuous between the zones with the intervening sections below the detection limit of the IP survey.

Line 0+00, which lies within a topographic low, shows the IP anomaly to be continuous. Elsewhere, due to local cover by younger formations, the IP response is discontinuous, resulting in apparent anomaly zoning.

This same condition described above would be expected to affect the geochemical anomaly response. Much of the area of the IP anomaly, correlates with copper geochemical anomalies; however, this geochemistry is locally discontinuous.

ZONE "A"

Zone "A" straddles the base line and can be traced from Line 12E to Line 8W. On most grid lines, a moderate depth of 50-100 metres is indicated.

The strongest IP response and best anomaly definition were recorded between Line 6W and Line 4E. This portion of the zone correlates in part with a copper geochemical anomaly and warrants further investigation.

Zone B, Zone C and Zone D may be one zone with the apparent effects resulting from elevation changes.

ZONE "B"

This zone is located at the south end of the grid from Line 6W to Line 12W; it is incomplete to the south. The depth to the source is shallow, with the possible exception of the very weak response on Line 6W. The IP response is weak and anomaly definition is poor. Correlation with the copper geochemical anomaly is good.

ZONE "C"

Moderately deep IP anomalies extending from Line 4W to 2E show weak response but are reasonably well defined. The apparent offset to the northeast from Zone B and Zone D, could be due to local relief.

ZONE "D"

Zone "D" occurs at the southwest edge of the grid from Line 2E to Line 10E. It is incomplete to the SW on all lines except Line 10E. The IP response is very weak and moderate depth to the source is indicated on all grid lines. Part of this zone correlates with anomalous copper geochemistry.

c) Grid #3

The comments made for Grid #2, regarding the influence of topography and formation dip on the depth to the favourable host formation, also apply to Grid #3. The IP survey has outlined two apparent parallel zones designated Zone A and Zone B. In fact, the metallic mineralization may be continuous between zones, but it could be below the detection limit of the IP survey.

ZONE "A"

Zone "A" is a weak magnitude, well defined IP anomaly that is

located in the vicinity of the base line. It occurs within a moderate level resistivity environment. Depth to the source is moderate on most lines except Line 2E and Line 4E, where it appears shallow. This could be explained by the lower elevation in the stream valley resulting in little or no depth to the top of the source.

The anomaly is strongest and best defined on Line 8E; here it correlates in part with copper geochemistry.

A magnetometer survey outlined a weak magnetic high of 150 - 1000 gammas correlating with the IP zone on Line 4E, Line 2E, Line 0+00 and Line 2W.

ZONE "B"

Zone "B" is weak in magnitude and poorly defined on most survey lines. Depth to the source is from 50 - 100 metres. The strongest IP effects were recorded on Line 6E where the anomaly is incomplete to the north.

There is no correlating magnetic anomaly and a copper geochemical high corresponds in part with Zone "B".

6. SUMMARY AND CONCLUSIONS

An Induced Polarization and Resistivity survey has been carried out over parts of Grid #1, Grid #2 and Grid #3 on the Lucky Joe Property.

An IP survey was carried out over Grid #1 by Riocanex in 1975. Line 0+00 was resurveyed by Phoenix for comparison purposes. Both IP effects and resistivity varied considerably in magnitude; however, the overall anomaly patterns and anomaly locations compared favourably.

Magnetometer surveying by Riocanex outlined different magnetic conditions on each grid. Grid #1 shows a moderate magnetic high immediately south of

the IP anomaly. Grid #2 was relatively flat magnetically. Grid #3 has a weak magnetic high that correlates with part of the Zone "A" IP anomaly.

The IP anomaly magnitudes vary from weak to moderate and they occur in a moderate resistivity level environment. Most IP anomalies show some depth to the source.

The IP anomalies within Grid #2 and Grid #3 have been correlated into several parallel zones. The potentially favourable biotite, muscovite schist formation is believed to be relatively flat-lying with only small variations in attitude. However, small variations in attitude in an area of moderate local relief can result in varying thicknesses of younger, covering rock and in varying depths to the host formation. The apparent IP zoning may outline areas where the host horizon is within the detection range of this IP survey. The mineralization causing the IP anomalies, could be continuous down-dip between the parallel zones.

Interesting IP anomalies occur in an area of favourable geology and show reasonable correlation with copper geochemical anomalies. Both Grid #2 and Grid #3 warrant further drill testing for possible commercial accumulations of copper mineralization. Since the strongest IP anomalies may not contain the largest copper concentrations, it will be necessary to consider also, the geological and geochemical conditions when choosing drill site locations.

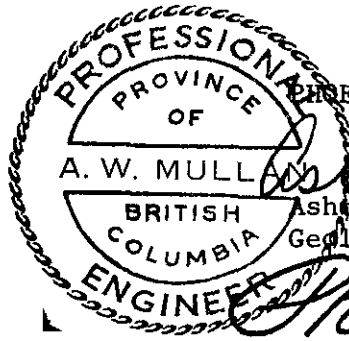

PHENIX GEOPHYSICS LIMITED

Ashton W. Mullan
Ashton W. Mullan, P.Eng.
Geologist

Philip G. Hallof
Philip G. Hallof, Ph.D., P.Eng.
Geophysicist



Specifications

Power Sources	: Internal DC power module containing 8 45V dry cell batteries, or internal AC power module with external 1 KVA, 2 KVA or 3 KVA motor generator.	DC POWER MODULE (BPS-1)
Ammeter Ranges	: 30 mA, 100 mA, 300 mA, 1A, 3A and 10A full scale.	Output Voltage
Meter Display	: A meter function switch selects the display of current level, regulation status, input frequency, output voltage, control battery voltage or line voltage.	: 8 x 45V dry cell batteries (Eveready 482, Mallory 202 or equivalent) are switched in series or parallel to provide output voltages of 90V, 180V, and 360V.
Current Regulation	: The change in output current is less than 0.2% for a 10% change in input voltage or electrode impedance.	Output Power
Output Waveform	: Either DC, single frequency, two frequencies simultaneously, or time domain (50% duty cycle). Frequencies of 0.078, 0.156, 0.313, 1.25, 2.5, and 5.0 Hz are standard, whereas 0.062, 0.125, 0.25, 1.0, 2.0, and 4.0 Hz are optionally available. The simultaneous transmission mode has 0.313 and 5.0 Hz as standard, whereas 0.156 and 2.5 Hz are optional.	: Recommended maximum output power is 30 watts. Absolute maximum output power is 100 watts.
Frequency Stability	: $\pm 1\%$ from -40° to +60°C is standard. A precision time base is optionally available for coherent detection and phase IP measurements.	Battery Life
Protection	: Current is turned off automatically if it exceeds 150% full scale or is less than 5% full scale.	: Normal field operation, with low output power results in an average battery life expectancy of one month. Operation with the absolute maximum output power results in much shorter battery life.
Case	: Non-conductive, high impact resistant plastic.	Control Supply
Dimensions	: 20 x 40 x 55 cm (9 x 16 x 22 inches).	: 4 x 6V lantern batteries (Eveready 409, Mallory 908 or equivalent) connected in series/parallel are used to provide the 40 to 70 mA required for the control circuitry. Average battery life expectancy is six months.
Weight	: 14 kg (31 lb) with DC power module. 16 kg (35 lb) with AC power module.	Operating Temperature
Standard Accessories	: Pack frame, manual. At least one of the two possible power modules is required. The AC power module in turn requires one of the external 1KVA, 2KVA or 3KVA motor generators and a connecting cable.	: 0°C to +60°C.
		AC POWER MODULE (AC-3)
		Output Voltage
		: 0V, 75V, 150V, 300V, 600V and 1200V.
		Output Power
		: Maximum continuous output power is 3 kw. This requires the 3KVA motor generator.
		Input Power
		: 350 to 1000 Hz, 60V (45V to 78V) 3 phase is standard. 120V (90V to 156V) and/or single phase may be link selected inside the module.
		Current Regulation
		: Achieved by feedback to the alternator of the motor generator unit.
		Operating Temperature
		: -40°C to +60°C.
		Thermal Protection
		: Thermostat turns off at 65°C and turns back on at 55°C internal temperature.



PHOENIX GEOPHYSICS LIMITED

Geophysical Consulting and Contracting, Instrument Manufacture, Sale and Lease.

Head Office: 200 Yorkland Blvd. Willowdale, Ont., Canada, M2J 1R6. Tel: (416) 493-6350
1424 - 355 Burrard St. Vancouver, B.C., Canada, V6C 2G8. Tel: (604) 684-2285
2430 N. Huachuca Dr., Tucson, Arizona, U.S.A. 85705. Tel: (602) 884-8542

IPV-1

Variable Frequency IP Receiver

Specifications

Input Impedance	: 2 Megohms	Damping	: Minimum damping is used for the high frequency voltage level adjustment. The damping for the FE measurement is continuously selectable.
Input Protection	: The input is protected from excessive voltages by a 10,000 ohm fuse resistor.	Calibration	: An internal 0.05 ohm $\pm 1.0\%$ resistor allows precise calibration of the system under all conditions.
Operating Frequencies	: \pm DC, 0.156, 0.313, 1.25, 2.5, and 5.0 Hz are standard. \pm DC, 0.125, 0.25, 1.0, 2.0 and 4.0 Hz are optionally available.	Instrument Noise	: 0.1% of reading for 1mv and all higher voltage levels. 0.2% of reading for 100 microvolt voltage level. 1.0% of reading for 10 microvolt voltage level.
Frequency Selection	: A front panel switch is used to select F1 or F2. These two frequencies may be set internally to any of the six available frequencies.	Operating Temperature	: -40°C to +60°C.
Voltage Ranges	: 1mv, 10mv, 100mv, 1v, and 10v full scale.	Temperature Drift	: The voltage drift is less than 2.0% and the FE drift is less than 0.1% over the entire operating temperature range.
Voltage Display	: A ten-turn precision dial potentiometer is used to balance the input signal. Since the readability of the dial is 0.025% of full scale, adequate resolution is maintained with voltage levels as low as a few microvolts.	Batteries	: Any 12V to 27 DC power supply may be used. Two 9V transistor radio batteries connected in series will provide one month normal field operation (battery drain is 4.5 mA).
Polarizability Display	: After the input voltage is balanced, the transmitter and receiver are switched to low frequency. The meter used for balancing now automatically displays FE in percent. Resolution is 0.1% over the range -5.0 to +20%. The same meter is used as a battery test.	Case	: Non-conductive, high impact resistant plastic.
Filters	: A double pole notch filter attenuates 50-60 Hz by 60 db. A low pass filter attenuates frequencies above the selected operating frequency by 18 db per octave. A telluric filter attenuates all frequencies below 0.125 Hz by 12 db per octave.	Dimensions	: With cover - 10 x 13 x 22 cm (4 x 5 x 9 in.).
		Weight	: 1.1 kg (2.5 lb) including cover, batteries and carrying strap.



PHOENIX GEOPHYSICS LIMITED

Geophysical Consulting and Contracting, Instrument Manufacture, Sale and Lease.

Head Office: 200 Yorkland Blvd. Willowdale, Ont., Canada, M2J 1R6. Tel: (416) 493-6350
1424 - 355 Burrard St. Vancouver, B.C., Canada, V6C 2G8. Tel: (604) 684-2285
2430 N. Huachuca Dr., Tucson, Arizona, U.S.A. 85705. Tel: (602) 884-8542

RIO TINTO CANADIAN EXPL. LTD.
 LUCKY JOE CREEK PROPERTY, GRID - 1
 DAWSON CITY AREA, YUKON TERRITORY

8S 7S 6S 5S 4S 3S 2S 1S 0 1N 2N 3N 4N 5N 6N 7N 8N 9N 10N

RESISTIVITY (APP) OHM METRES

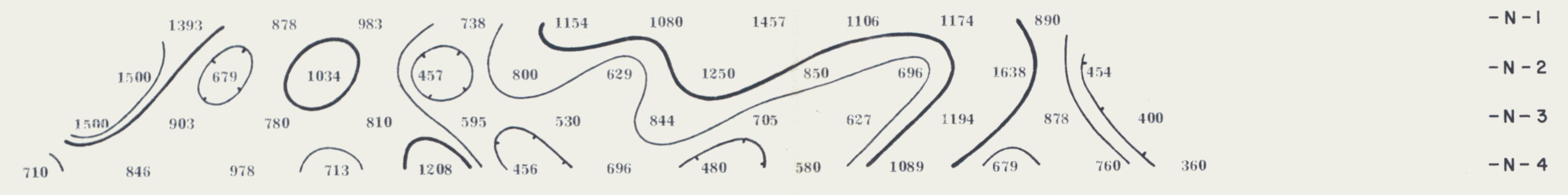

8S 7S 6S 5S 4S 3S 2S 1S 0 1N 2N 3N 4N 5N 6N 7N 8N 9N 10N

METAL FACTOR (APP)

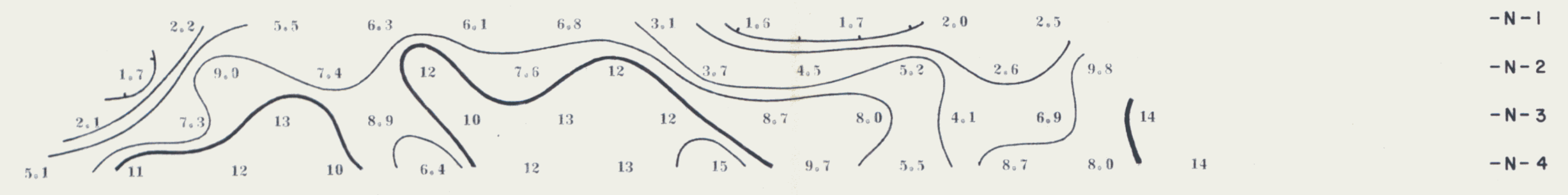

8S 7S 6S 5S 4S 3S 2S 1S 0 1N 2N 3N 4N 5N 6N 7N 8N 9N 10N

FREQUENCY EFFECT (APP) IN %

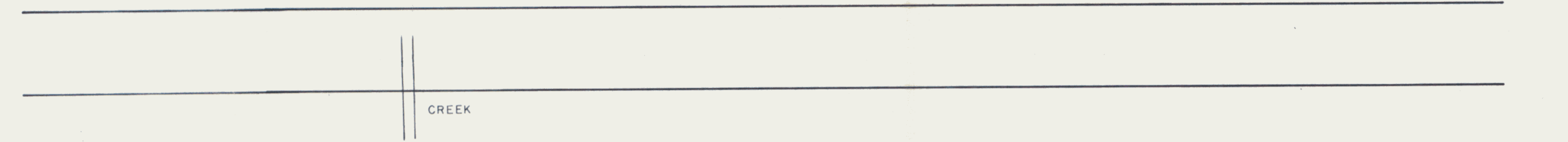
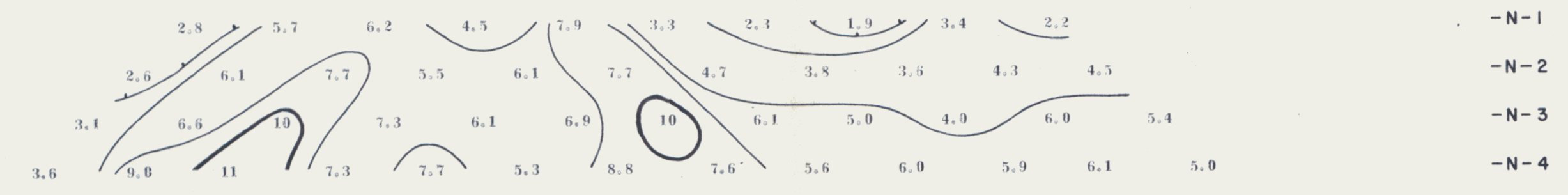

LINE NO. - 0 - (TEST LINE)

ELECTRODE CONFIGURATION

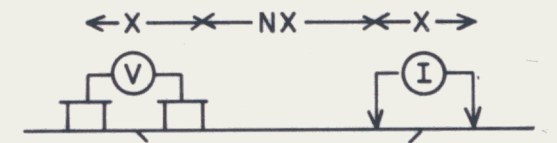

PLOTTING POINT X = 100 m.

SURFACE PROJECTION OF ANOMALOUS ZONE

- DEFINITE
- PROBABLE
- POSSIBLE

FREQUENCIES 0.3 - 5.0 HZ.

DATE SURVEYED JUNE 1978

NOTE - CONTOURS AT LOGARITHMIC INTERVALS 1, -1.5, -2, -3, -5, -7.5, -10

APPROVED OF
Richard H. Hall
 BRITISH COLUMBIA
 ENGINEER
 DATE _____

Expiry Date: February 25, 1979

PHOENIX GEOPHYSICS LIMITED
 INDUCED POLARIZATION AND RESISTIVITY SURVEY

PHOENIX GEOPHYSICS LIMITED
INDUCED POLARIZATION AND RESISTIVITY SURVEY
PLAN MAP

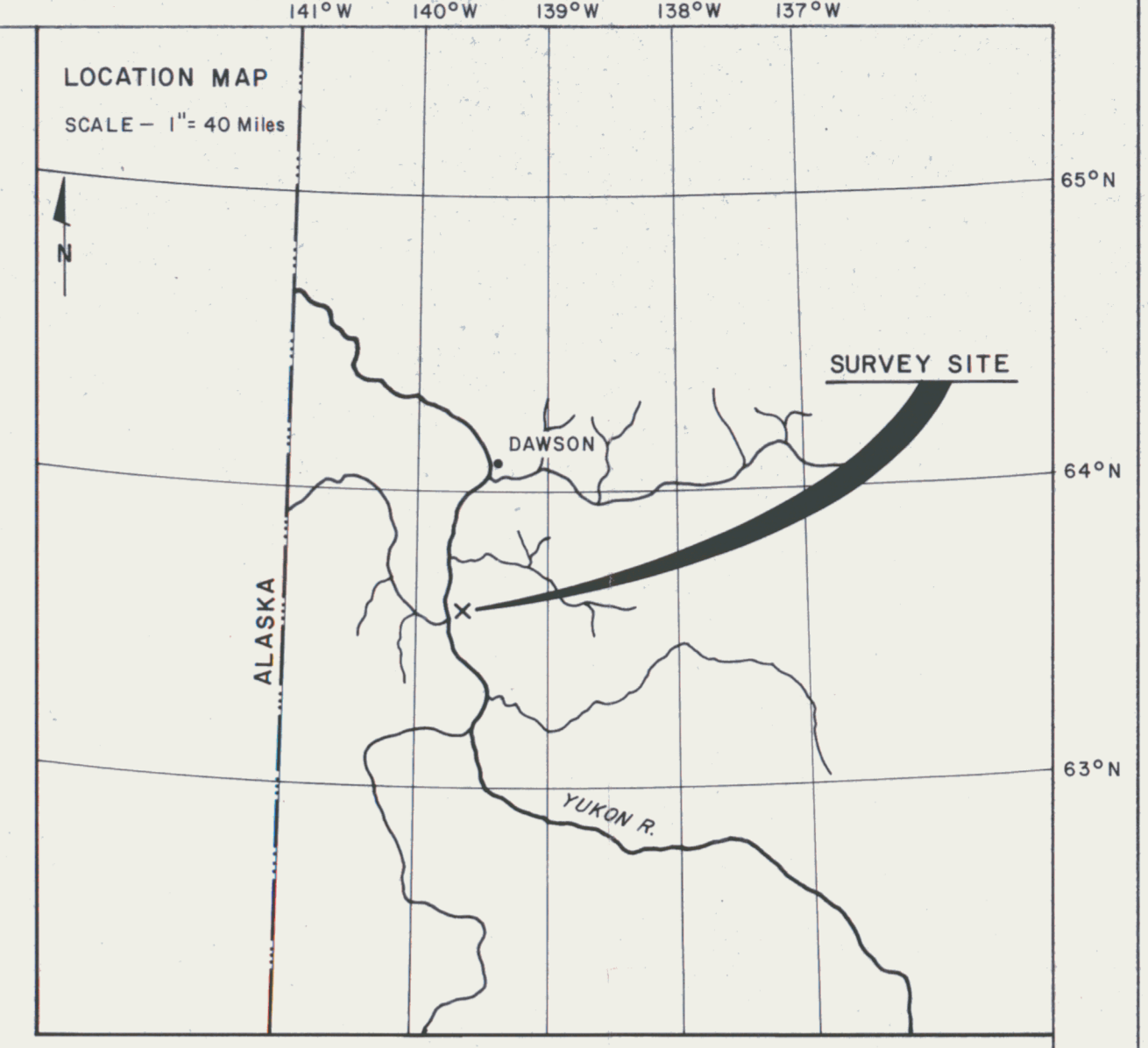
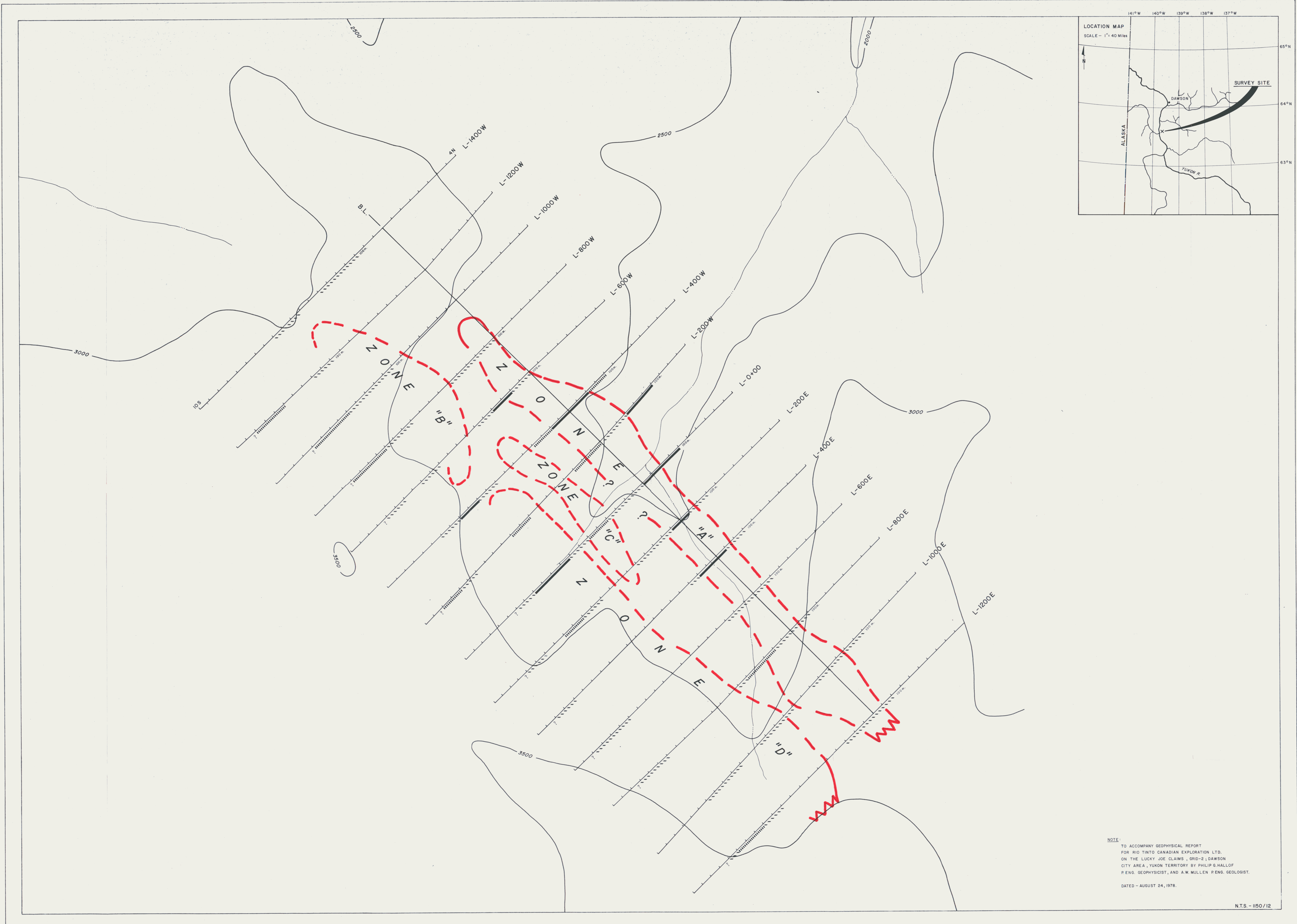

NOTE:
TO ACCOMPANY GEOPHYSICAL REPORT
FOR RIO TINTO CANADIAN EXPLORATION LTD.
ON THE LUCKY JOE CLAIMS, GRID-2, DAWSON
CITY AREA, YUKON TERRITORY BY PHILIP G. HALLOF
P. ENG. GEOPHYSICIST, AND A.W. MULLEN P. ENG. GEOLOGIST.
DATED - AUGUST 24, 1978.

N.T.S. - 1150/12

N
 SURFACE PROJECTION
OF ANOMALOUS ZONE
 DEFINITE
 PROBABLE
 POSSIBLE
 NUMBER AT END OF ANOMALIES
INDICATE SPREAD USED.

RIO TINTO CANADIAN EXPL. LTD.
 LUCKY JOE CREEK PROPERTY, GRID-2
 DAWSON CITY AREA, YUKON TERRITORY



ANOMALOUS I.P. ZONE

DRAWN BY
 PHILIP G. HALLOF
 P. ENG. GEOPHYSICIST
 24/8/78
 EXPIRY DATE: FEBRUARY 25, 1979

DWG. NO. - I.P.P. - 4042

PHOENIX GEOPHYSICS LIMITED

INDUCED POLARIZATION AND RESISTIVITY SURVEY

PLAN MAP

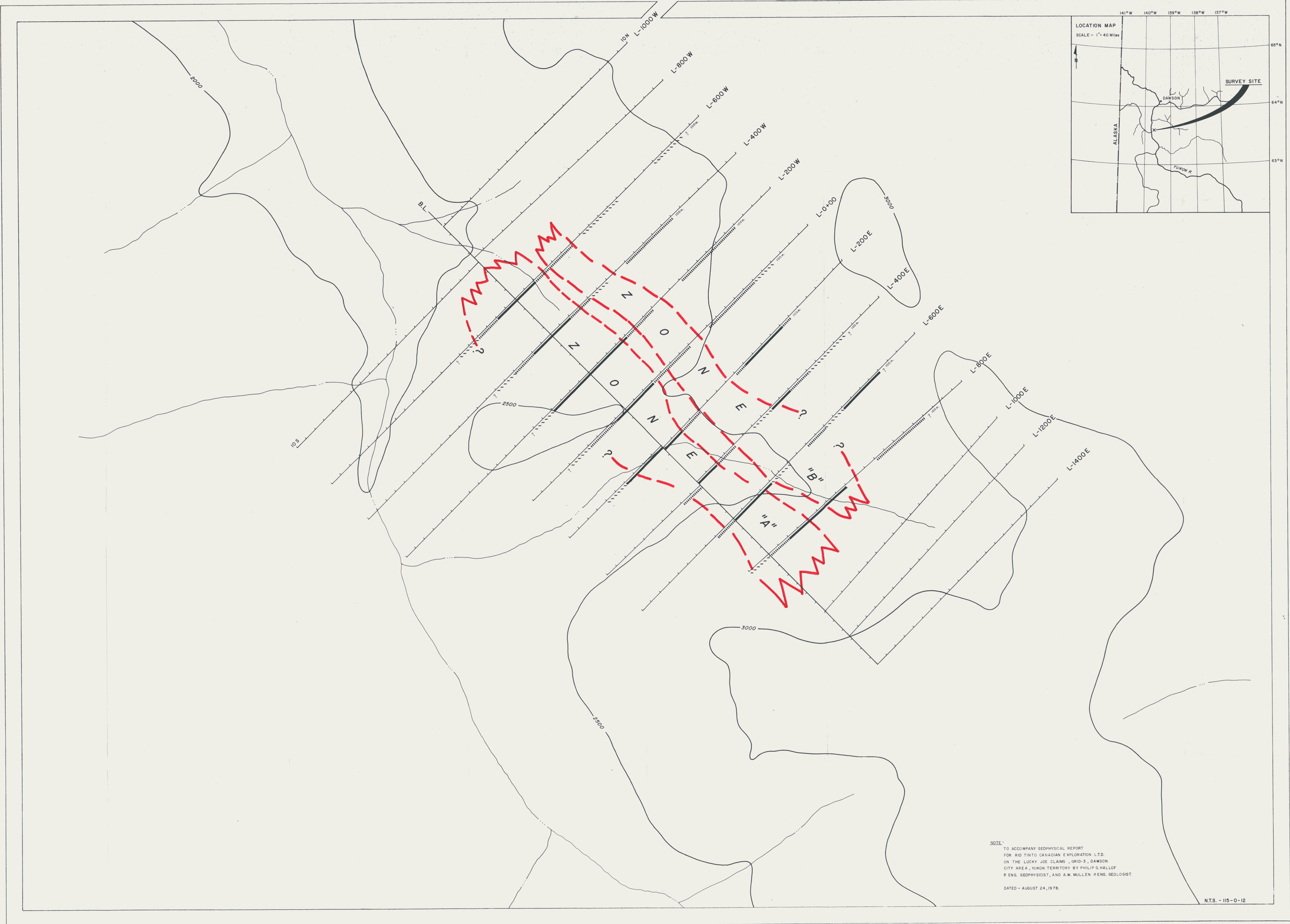
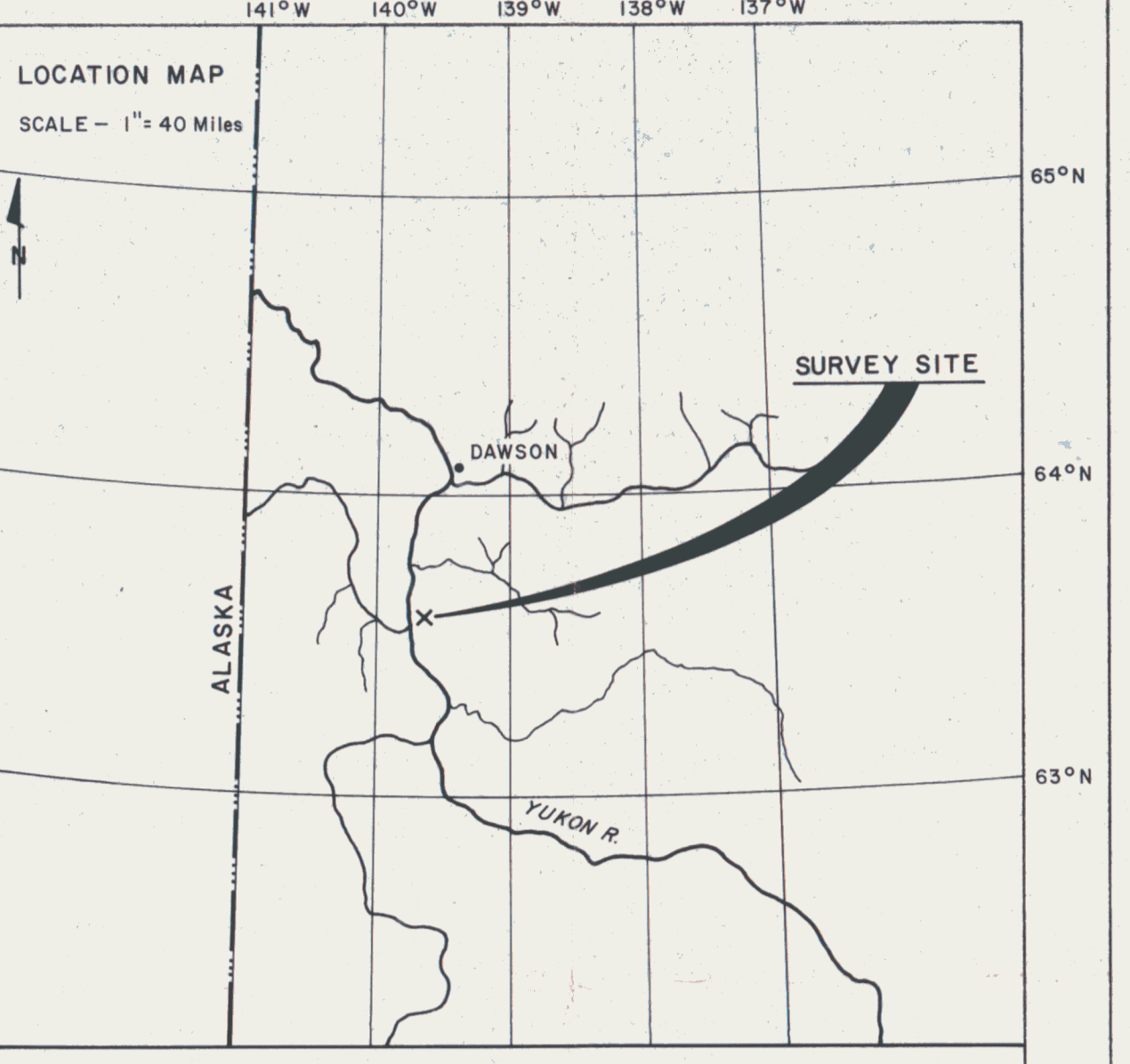

NOTE:
TO ACCOMPANY GEOPHYSICAL REPORT
FOR RIO TINTO CANADIAN EXPLORATION LTD.
ON THE LUCKY JOE CLAIMS, GRID-3, DAWSON
CITY AREA, YUKON TERRITORY BY PHILIP G. HALLOP
P. ENG. GEOPHYSICIST, AND A.W. MULLEN P. ENG. GEOLOGIST
DATED - AUGUST 24, 1978.

N.T.S. - 115-0-12



SURFACE PROJECTION
OF ANOMALOUS ZONE

DEFINITE

PROBABLE

POSSIBLE

NUMBER AT END OF ANOMALIES
INDICATE SPREAD USED.

RIO TINTO CANADIAN EXPL. LTD.
LUCKY JOE CREEK PROPERTY, GRID-3
DAWSON CITY AREA, YUKON TERRITORY

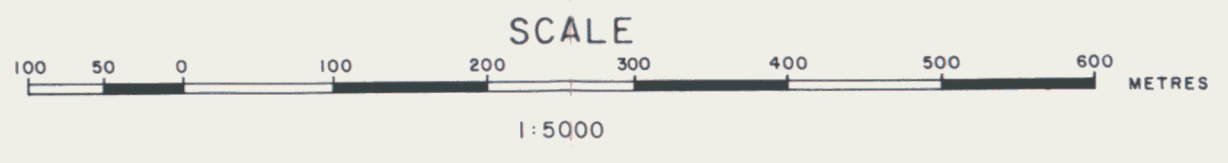

ANOMALOUS I.P. ZONE

DRAWN: R.C.N.
DATE: FEBRUARY 25, 1978
PHILIP G. HALLOP
P. ENG. GEOPHYSICIST
A.W. MULLEN
P. ENG. GEOLOGIST
Epiry Date: February 25, 1979

RIO TINTO CANADIAN EXPL. LTD.
 LUCKY JOE CREEK PROPERTY , GRID - 2
 DAWSON CITY AREA , YUKON TERRITORY

LINE NO.- 1400 W

ELECTRODE CONFIGURATION

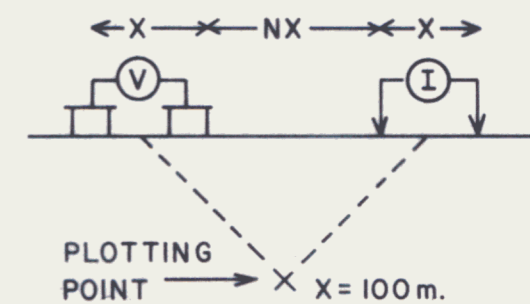

SURFACE PROJECTION OF ANOMALOUS ZONE

DEFINITE
 PROBABLE
 POSSIBLE

FREQUENCIES 0.3 - 5.0 HZ.

DATE SURVEYED JUNE 1978

APPROVED

Philip St. Hallop
 P. G. HALLOP
 BRITISH COLUMBIA
 ENGINEER

NOTE - CONTOURS AT LOGARITHMIC INTERVALS 1, -1.5, -2, -3, -5, -7.5, -10

DATE

Expiry Date: February 25, 1979

PHOENIX GEOPHYSICS LIMITED
 INDUCED POLARIZATION AND RESISTIVITY SURVEY

10S 9S 8S 7S 6S 5S 4S 3S 2S 1S 0 1N 2N 3N 4N 5N

RESISTIVITY (APP) OHM METRES

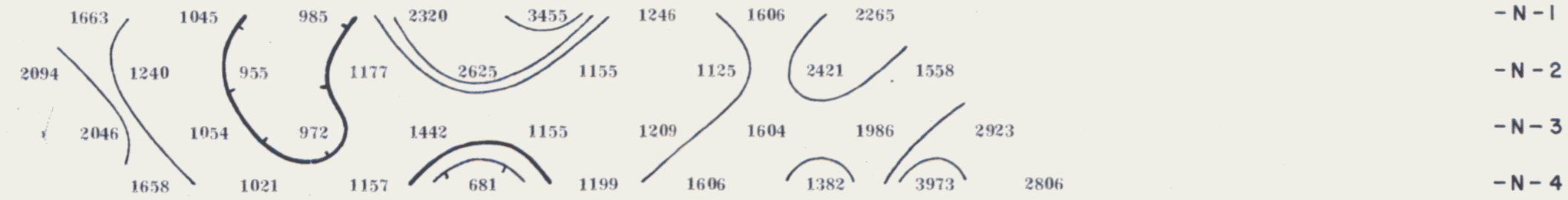

10S 9S 8S 7S 6S 5S 4S 3S 2S 1S 0 1N 2N 3N 4N 5N

METAL FACTOR (APP)

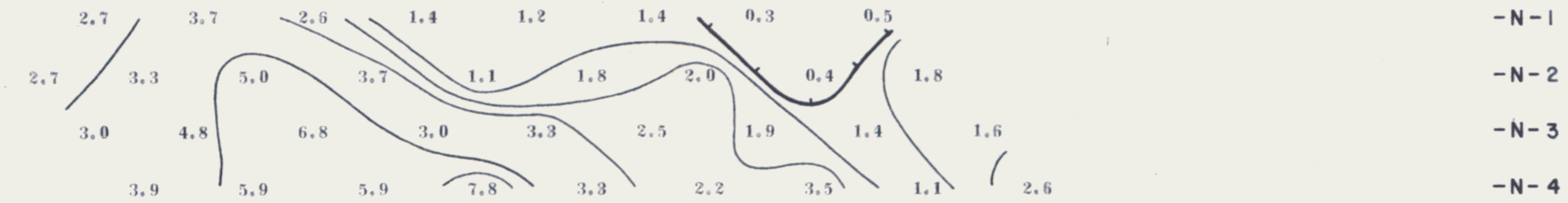

10S 9S 8S 7S 6S 5S 4S 3S 2S 1S 0 1N 2N 3N 4N 5N

FREQUENCY EFFECT (APP) IN %

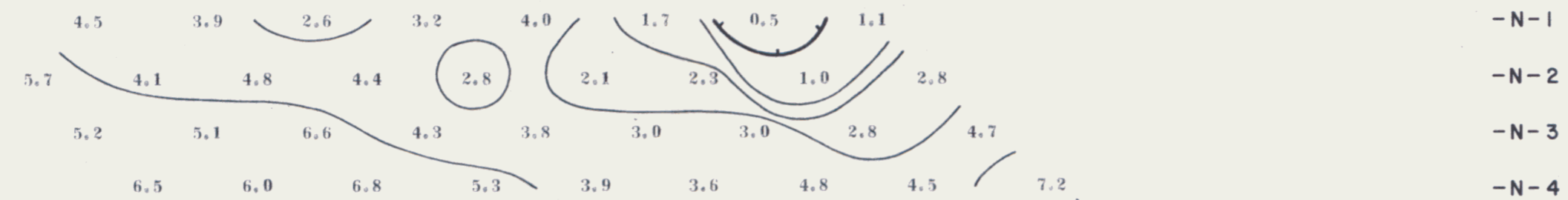

1800 Y
1600 Y
1400 Y
1200 Y
1000 Y
800 Y

TOPOGRAPHY

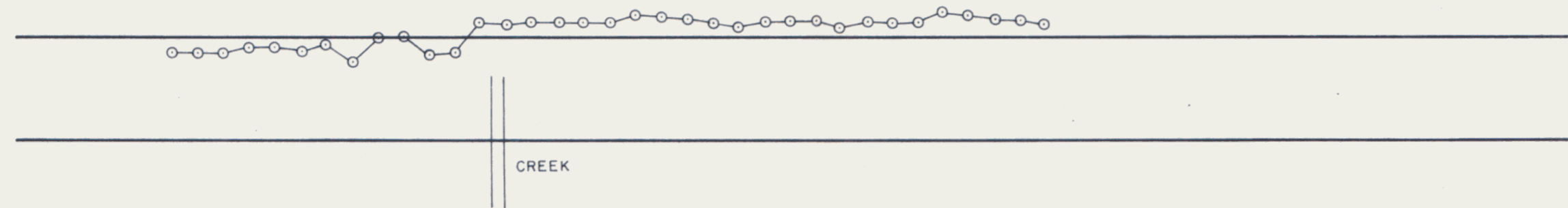

CREEK

RIO TINTO CANADIAN EXPL. LTD.
 LUCKY JOE CREEK PROPERTY, GRID-2
 DAWSON CITY AREA, YUKON TERRITORY

RESISTIVITY (APP.) OHM METRES

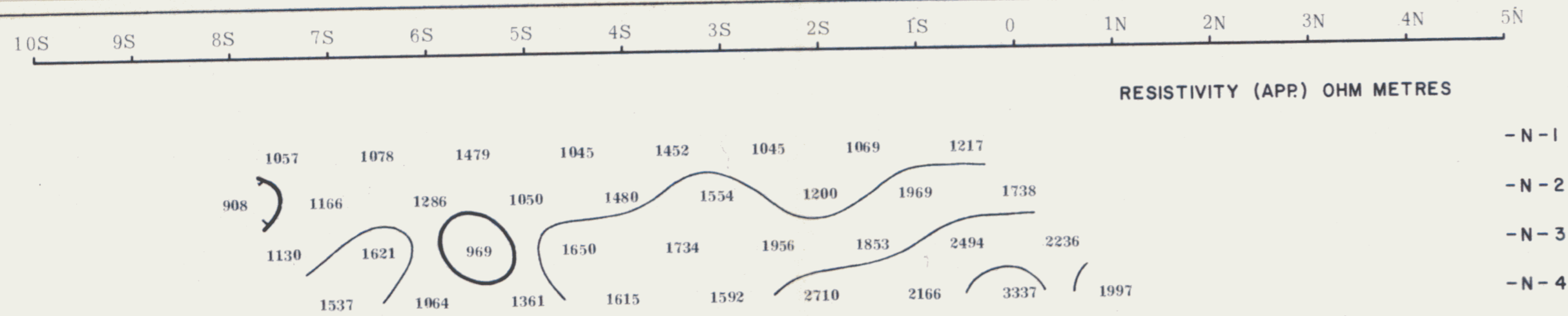

METAL FACTOR (APP.)

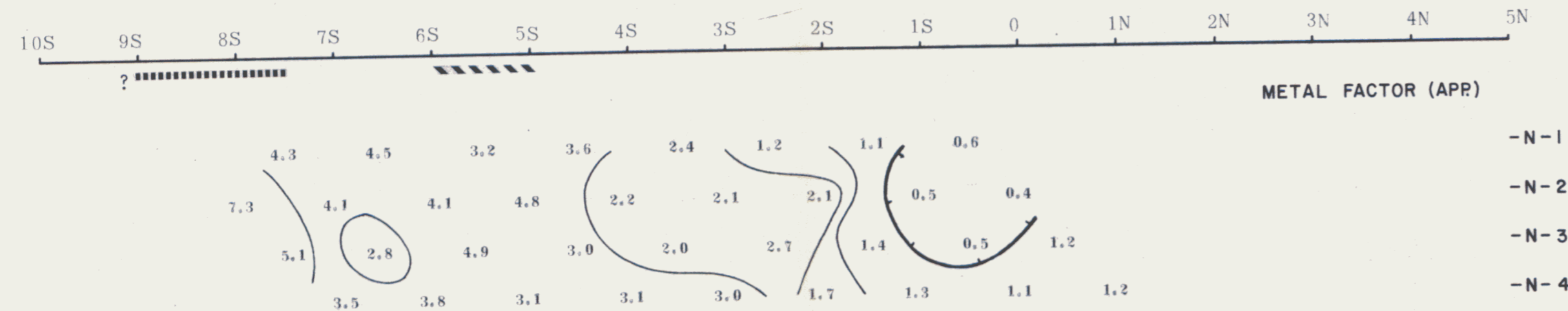

FREQUENCY EFFECT (APP.) IN %

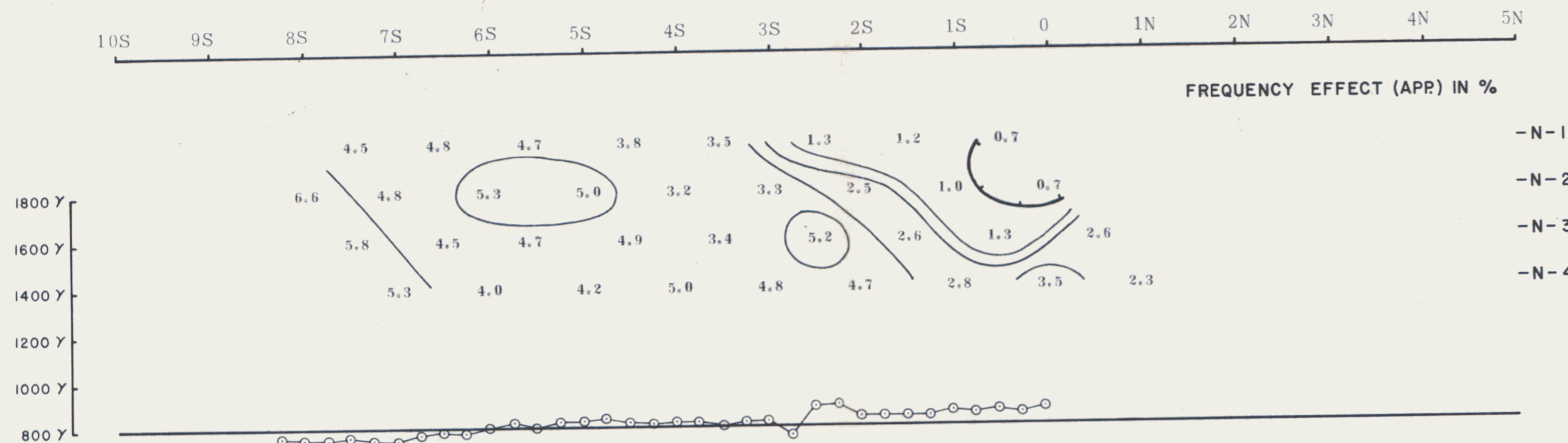

TOPOGRAPHY

LINE NO.- 1200W

ELECTRODE CONFIGURATION

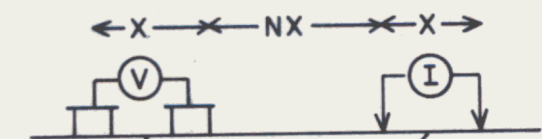

PLOTTING POINT X = 100m.

SURFACE PROJECTION OF ANOMALOUS ZONE

DEFINITE
 PROBABLE
 POSSIBLE

FREQUENCIES 0.3-5.0 HZ.

DATE SURVEYED JUNE 1978

APPROVED

Philip G. Hall
 P. G. HALLOP
 BRITISH COLUMBIA
 ENGINEER

NOTE - CONTOURS AT LOGARITHMIC INTERVALS 1, -1.5, -2, -3, -5, -7.5, -10

DATE

Expiry Date: February 25, 1979

PHOENIX GEOPHYSICS LIMITED
 INDUCED POLARIZATION AND RESISTIVITY SURVEY

RIO TINTO CANADIAN EXPL. LTD.
 LUCKY JOE CREEK PROPERTY , GRID - 2
 DAWSON CITY AREA , YUKON TERRITORY

10S 9S 8S 7S 6S 5S 4S 3S 2S 1S 0 1N 2N 3N 4N 5N

RESISTIVITY (APP.) OHM METRES

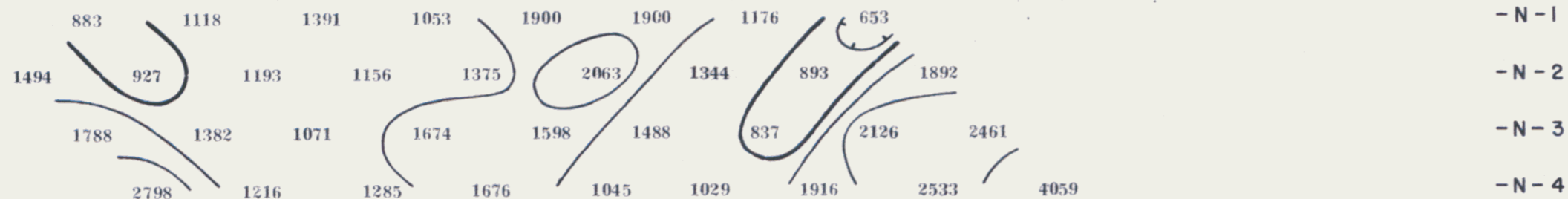

10S 9S 8S 7S 6S 5S 4S 3S 2S 1S 0 1N 2N 3N 4N 5N

METAL FACTOR (APP.)

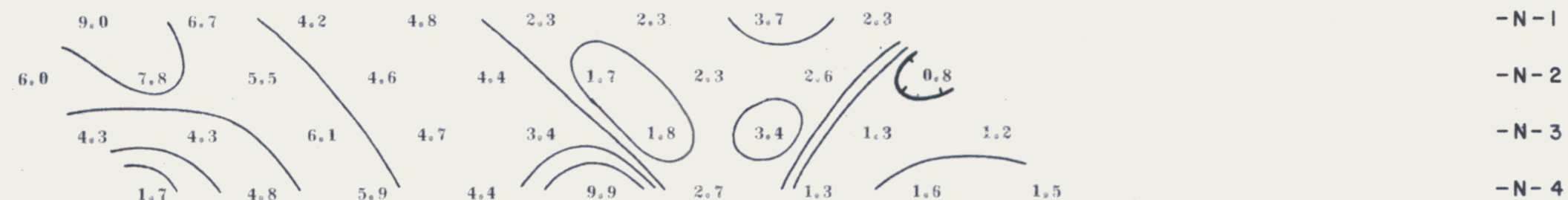

10S 9S 8S 7S 6S 5S 4S 3S 2S 1S 0 1N 2N 3N 4N 5N

FREQUENCY EFFECT (APP.) IN %

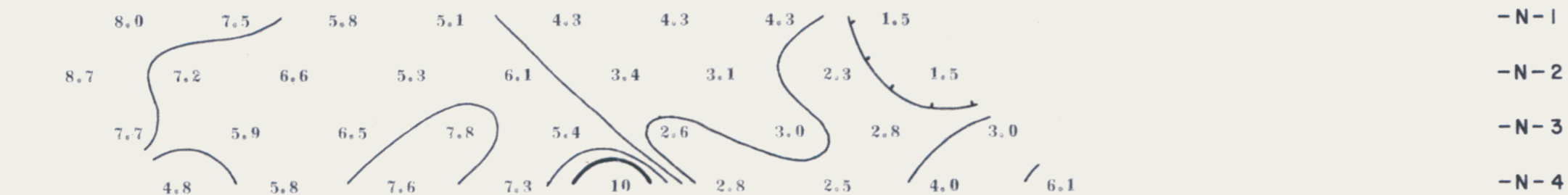

1800 Y
1600 Y
1400 Y
1200 Y
1000 Y
800 Y

TOPOGRAPHY

LINE NO.- 1000 W

ELECTRODE CONFIGURATION

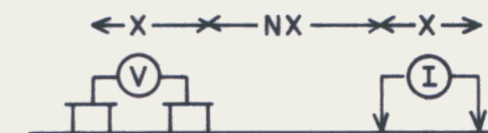

PLOTTING POINT X = 100 m.

SURFACE PROJECTION OF ANOMALOUS ZONE

DEFINITE
 PROBABLE
 POSSIBLE

FREQUENCIES 0.3-5.0 HZ.

DATE SURVEYED JUNE 1978

APPROVED

Philip St. John
 P. G. HALLOP
 BRITISH COLUMBIA
 ENGINEER

DATE

Expiry Date: February 25, 1979

NOTE - CONTOURS AT LOGARITHMIC INTERVALS 1, -1.5, -2, -3, -5, -7.5, -10

PHOENIX GEOPHYSICS LIMITED
 INDUCED POLARIZATION AND RESISTIVITY SURVEY

RIO TINTO CANADIAN EXPL. LTD.
 LUCKY JOE CREEK PROPERTY , GRID - 2
 DAWSON CITY AREA , YUKON TERRITORY

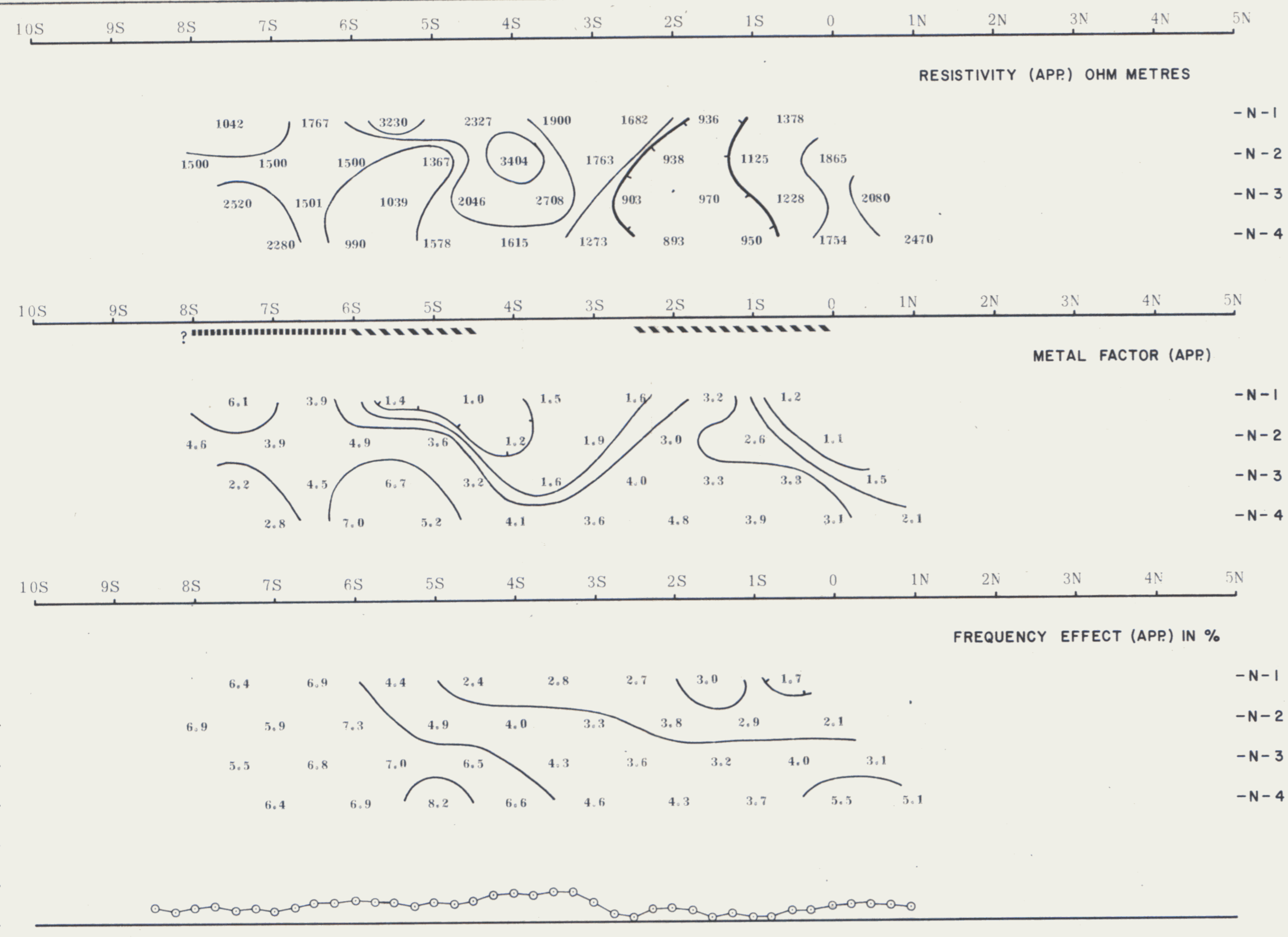

LINE NO.- 800W

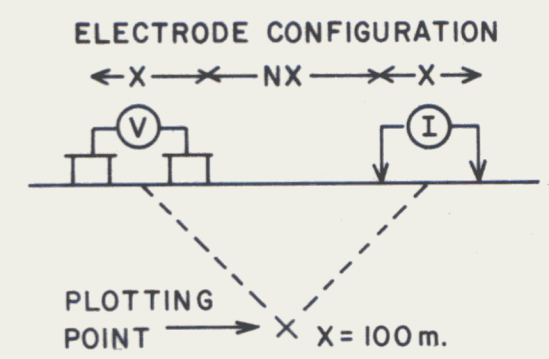

SURFACE PROJECTION OF ANOMALOUS ZONE

DEFINITE

PROBABLE

POSSIBLE

FREQUENCIES 0.3-5.0 HZ.

DATE SURVEYED JUNE 1978

APPROVED OF

 P. G. HALLOF
 BRITISH COLUMBIA
 ENGINEER

NOTE - CONTOURS AT LOGARITHMIC INTERVALS 1, -1.5, -2, -3, -5, -7.5, -10

Expiry Date: February 25, 1978

PHOENIX GEOPHYSICS LIMITED
 INDUCED POLARIZATION AND RESISTIVITY SURVEY

RIO TINTO CANADIAN EXPL. LTD.

LUCKY JOE CREEK PROPERTY , GRID - 2

DAWSON CITY AREA , YUKON TERRITORY

LINE NO.- 600W

ELECTRODE CONFIGURATION

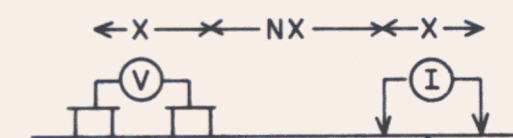

PLOTTING POINT → X = 100 m.

SURFACE PROJECTION OF ANOMALOUS ZONE

DEFINITE **—————**
 PROBABLE **.....**
 POSSIBLE **///////**

FREQUENCIES 0.3 - 5.0 HZ.

DATE SURVEYED JUNE 1978

APPROVED

Philip St. Hall
 P. G. HALLOF
 BRITISH COLUMBIA
 ENGINEER

NOTE - CONTOURS AT LOGARITHMIC INTERVALS 1, -1.5, -2, -3, -5, -7.5, -10

DATE

Expiry Date: February 25, 1979

PHOENIX GEOPHYSICS LIMITED

INDUCED POLARIZATION AND RESISTIVITY SURVEY

10S 9S 8S 7S 6S 5S 4S 3S 2S 1S 0 1N 2N 3N 4N 5N

RESISTIVITY (APP.) OHM METRES

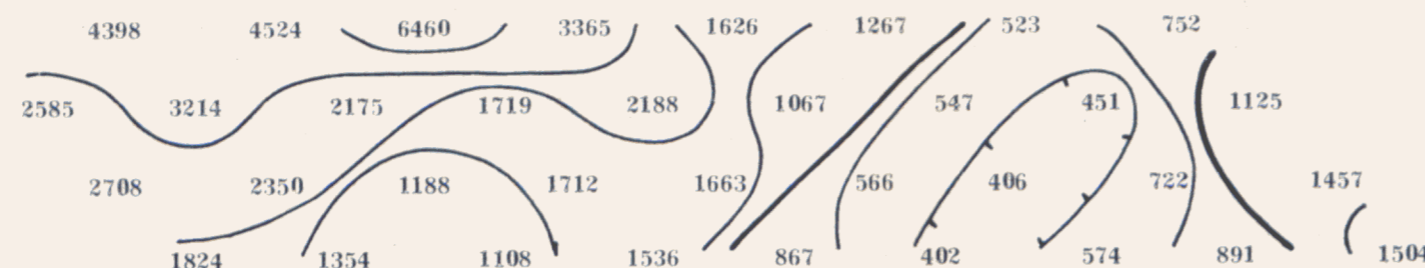

-N-1
-N-2
-N-3
-N-4

10S 9S 8S 7S 6S 5S 4S 3S 2S 1S 0 1N 2N 3N 4N 5N

METAL FACTOR (APP.)

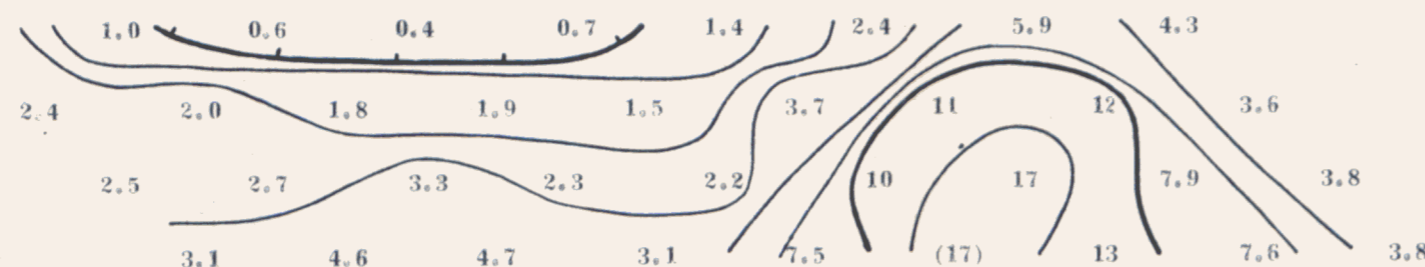

-N-1
-N-2
-N-3
-N-4

10S 9S 8S 7S 6S 5S 4S 3S 2S 1S 0 1N 2N 3N 4N 5N

FREQUENCY EFFECT (APP.) IN %

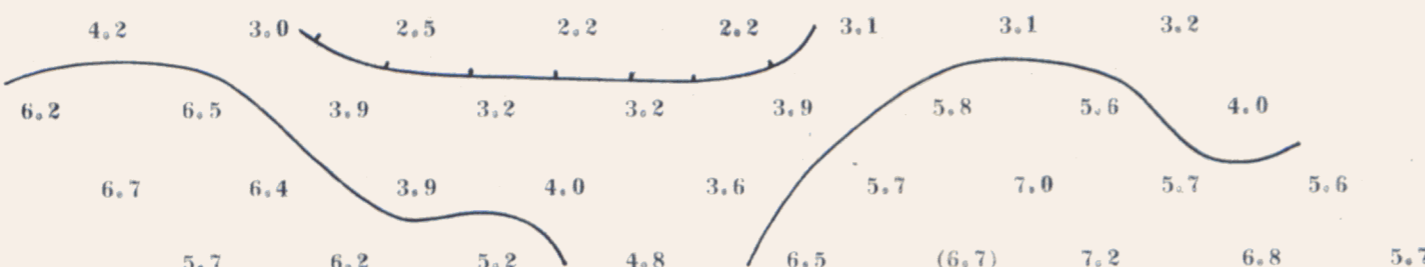

-N-1
-N-2
-N-3
-N-4

1800 Y
1600 Y
1400 Y
1200 Y
1000 Y
800 Y

TOPOGRAPHY

CREEK

RIO TINTO CANADIAN EXPL. LTD.

LUCKY JOE CREEK PROPERTY, GRID-2

DAWSON CITY AREA, YUKON TERRITORY

LINE NO.- 400W

ELECTRODE CONFIGURATION

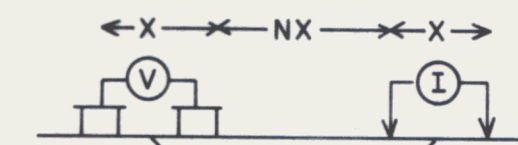

PLOTTING POINT X=100m.

SURFACE PROJECTION OF ANOMALOUS ZONE

DEFINITE
 PROBABLE
 POSSIBLE

FREQUENCIES 0.3-5.0 HZ.

DATE SURVEYED JUNE 1978

APPROVED

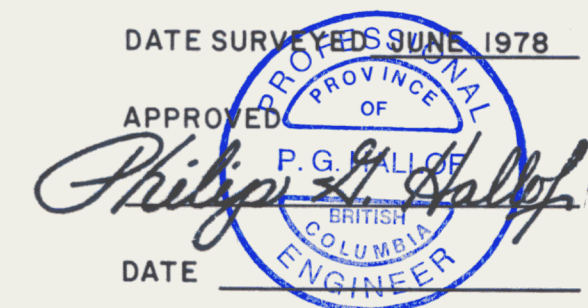

NOTE - CONTOURS AT LOGARITHMIC INTERVALS 1, -1.5, -2, -3, -5, -7.5, -10

DATE

Expiry Date: February 25, 1979

PHOENIX GEOPHYSICS LIMITED

INDUCED POLARIZATION AND RESISTIVITY SURVEY

10S 9S 8S 7S 6S 5S 4S 3S 2S 1S 0 1N 2N 3N 4N 5N 6N

RESISTIVITY (APP) OHM METRES

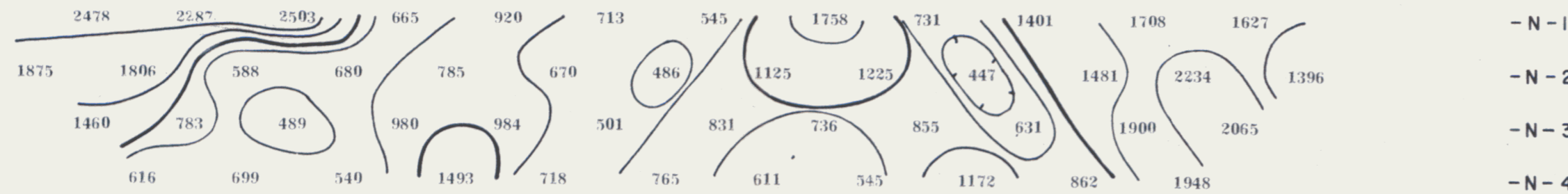

10S 9S 8S 7S 6S 5S 4S 3S 2S 1S 0 1N 2N 3N 4N 5N 6N

METAL FACTOR (APP)

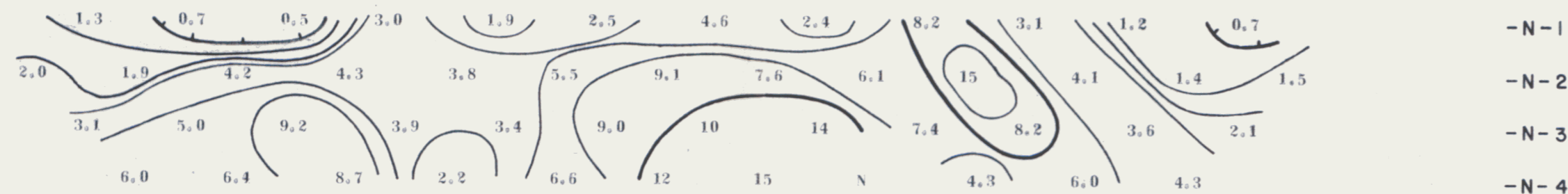

10S 9S 8S 7S 6S 5S 4S 3S 2S 1S 0 1N 2N 3N 4N 5N 6N

FREQUENCY EFFECT (APP) IN %

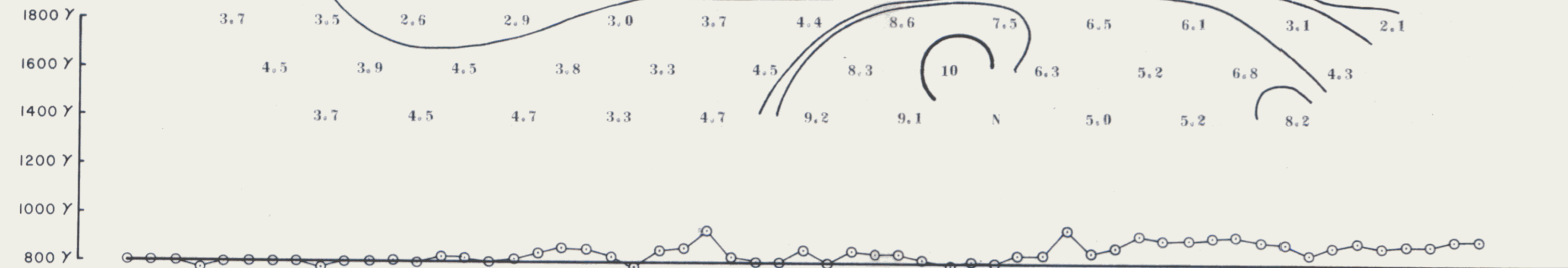
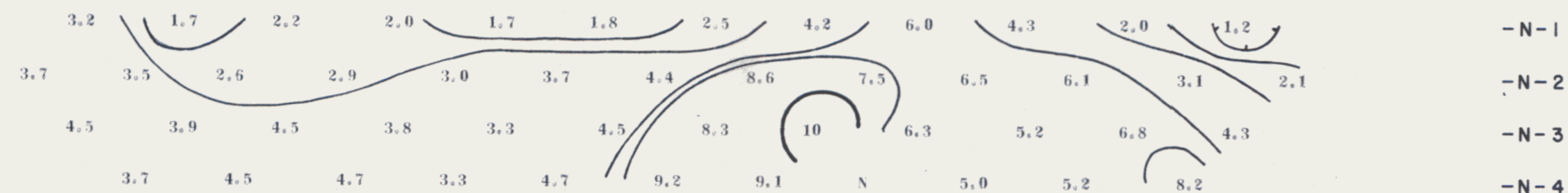

TOPOGRAPHY

CREEK

10S 9S 8S 7S 6S 5S 4S 3S 2S 1S 0 1N 2N 3N 4N 5N 6N

RESISTIVITY (APP) OHM METRES



10S 9S 8S 7S 6S 5S 4S 3S 2S 1S 0 1N 2N 3N 4N 5N 6N

METAL FACTOR (APP)

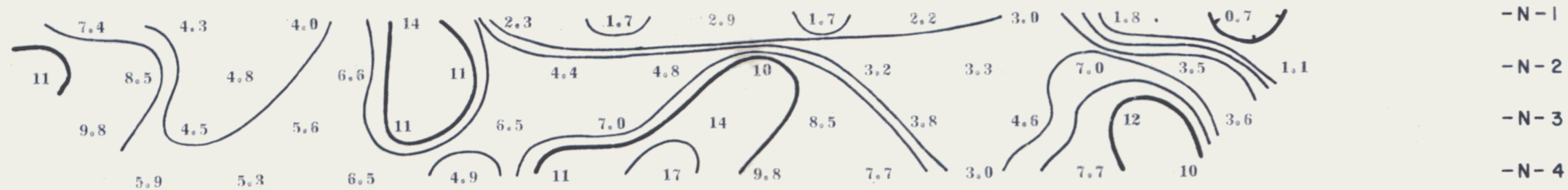

10S 9S 8S 7S 6S 5S 4S 3S 2S 1S 0 1N 2N 3N 4N 5N 6N

FREQUENCY EFFECT (APP) IN %

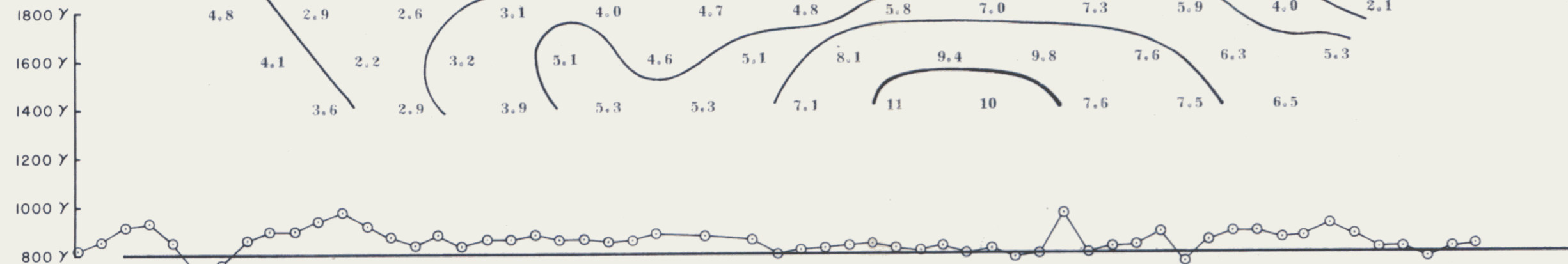
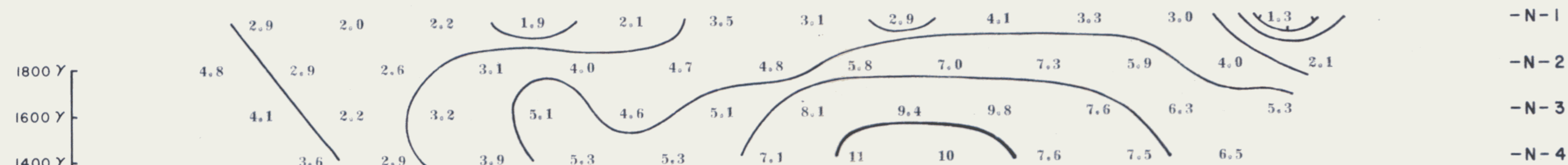

TOPOGRAPHY

CREEK

RIO TINTO CANADIAN EXPL. LTD.
 LUCKY JOE CREEK PROPERTY , GRID - 2
 DAWSON CITY AREA , YUKON TERRITORY

LINE NO.- 200 W

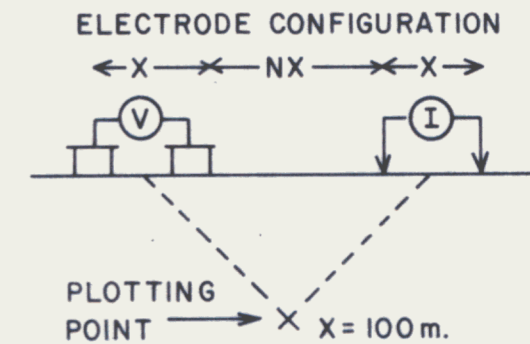

SURFACE PROJECTION OF ANOMALOUS ZONE

DEFINITE
 PROBABLE
 POSSIBLE

FREQUENCIES 0.3-5.0 HZ.

DATE SURVEYED JUNE 1978

APPROVED

Philip St. Hall
 P.G.H. HALLOF
 BRITISH COLUMBIA
 ENGINEER

NOTE - CONTOURS AT LOGARITHMIC INTERVALS 1, -1.5, -2, -3, -5, -7.5, -10

DATE

Expiry Date: February 25, 1979

PHOENIX GEOPHYSICS LIMITED
 INDUCED POLARIZATION AND RESISTIVITY SURVEY

RIO TINTO CANADIAN EXPL. LTD.

LUCKY JOE CREEK PROPERTY , GRID - 2

DAWSON CITY AREA , YUKON TERRITORY

LINE NO.- 00

ELECTRODE CONFIGURATION

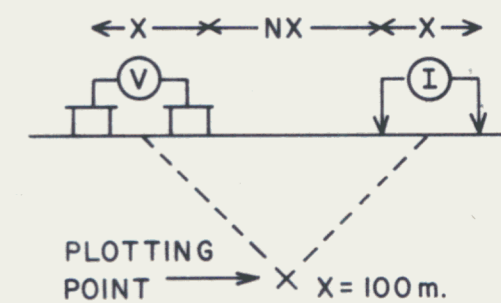

SURFACE PROJECTION OF ANOMALOUS ZONE

DEFINITE **—————**
 PROBABLE **.....**
 POSSIBLE **///////**

FREQUENCIES 0.3 - 5.0 HZ.

DATE SURVEYED JUNE 1978

APPROVED OF

Philip St. Hallop
 P. G. HALLOP
 BRITISH COLUMBIA
 ENGINEER

NOTE - CONTOURS AT LOGARITHMIC INTERVALS 1, -1.5, -2, -3, -5, -7.5, -10

DATE

Expiry Date: February 25, 1979

PHOENIX GEOPHYSICS LIMITED

INDUCED POLARIZATION AND RESISTIVITY SURVEY

10S 9S 8S 7S 6S 5S 4S 3S 2S 1S 0 1N 2N 3N 4N 5N

RESISTIVITY (APP.) OHM METRES

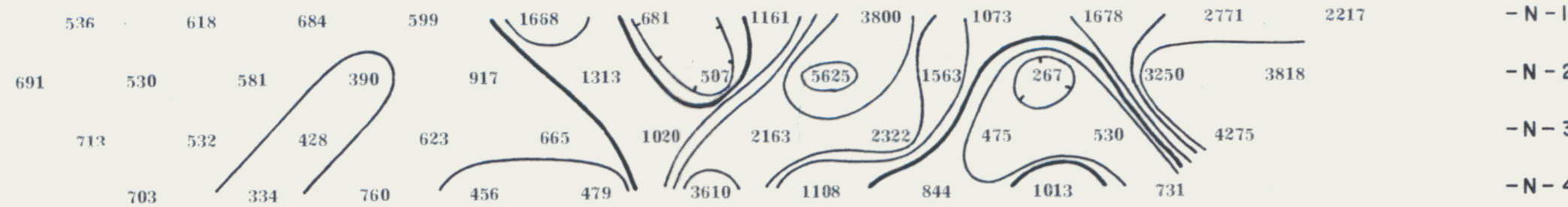

10S 9S 8S 7S 6S 5S 4S 3S 2S 1S 0 1N 2N 3N 4N 5N

METAL FACTOR (APP.)

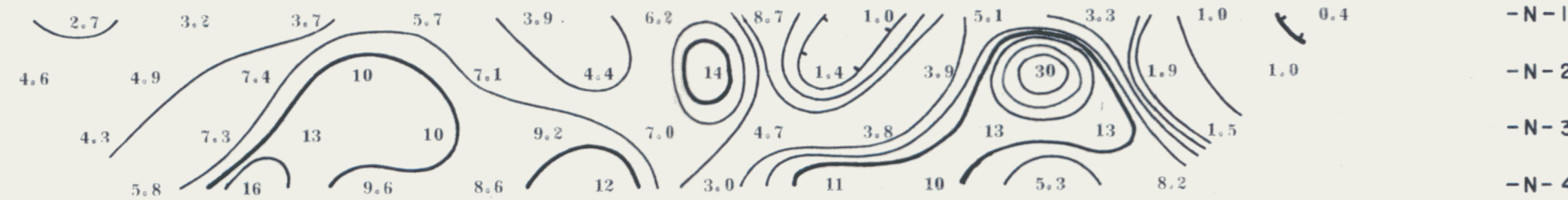

10S 9S 8S 7S 6S 5S 4S 3S 2S 1S 0 1N 2N 3N 4N 5N

FREQUENCY EFFECT (APP.) IN %

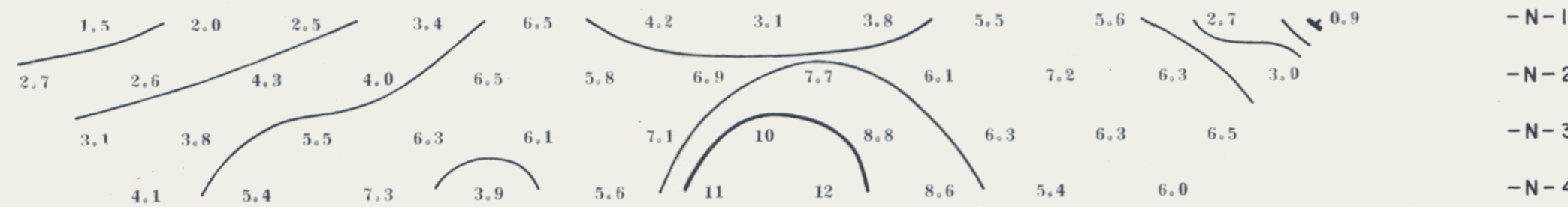

1800 Y
1600 Y
1400 Y
1200 Y
1000 Y
800 Y

TOPOGRAPHY



CREEK

RIO TINTO CANADIAN EXPL. LTD.
 LUCKY JOE CREEK PROPERTY , GRID - 2
 DAWSON CITY AREA , YUKON TERRITORY

10+50S 9+50S 8+50S 7+50S 6+50S 5+50S 4+50S 3+50S 2+50S 1+50S 0+50S 0+50N 1+50N 2+50N 3+50N 4+50N 5+50N

RESISTIVITY (APP) OHM METRES

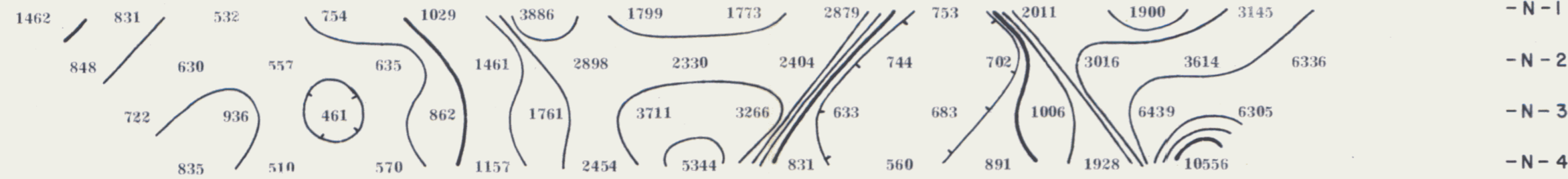

10+50S 9+50S 8+50S 7+50S 6+50S 5+50S 4+50S 3+50S 2+50S 1+50S 0+50S 0+50N 1+50N 2+50N 3+50N 4+50N 5+50N

METAL FACTOR (APP)

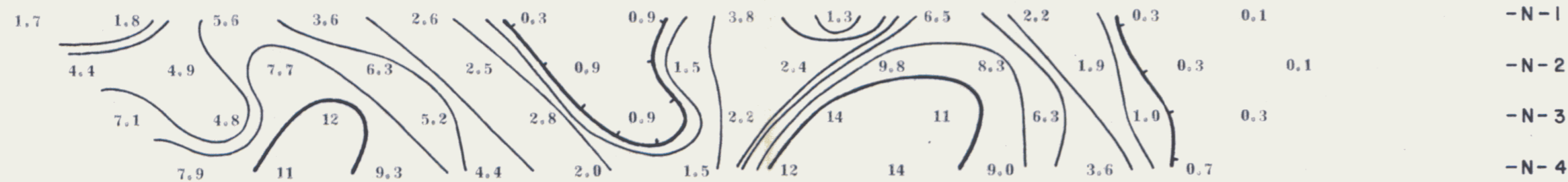

10+50S 9+50S 8+50S 7+50S 6+50S 5+50S 4+50S 3+50S 2+50S 1+50S 0+50S 0+50N 1+50N 2+50N 3+50N 4+50N 5+50N

FREQUENCY EFFECT (APP) IN %

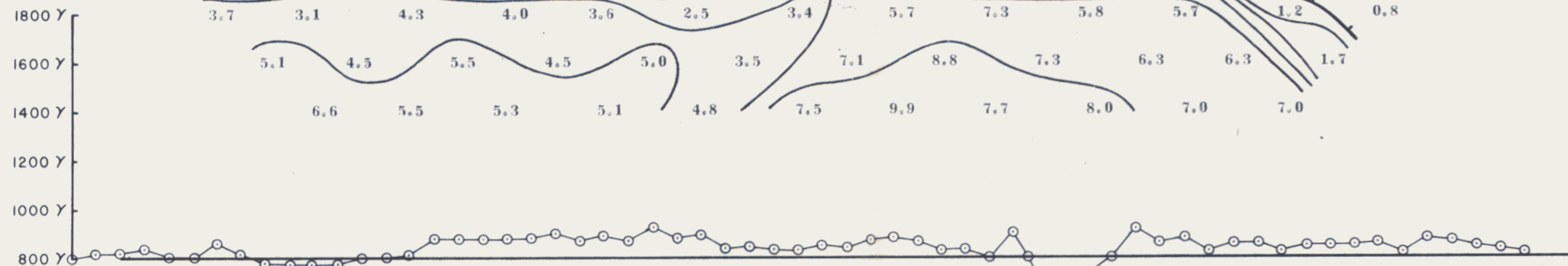
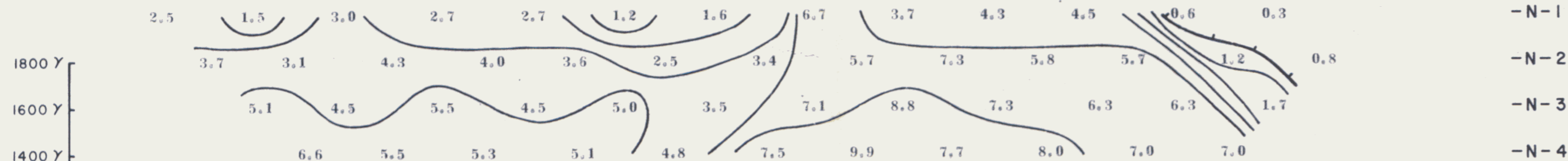

LINE NO.- 200 E

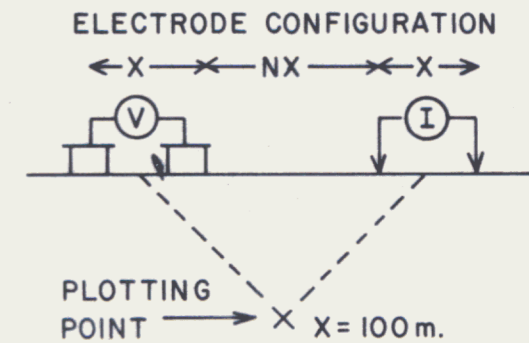

SURFACE PROJECTION OF ANOMALOUS ZONE

DEFINITE

PROBABLE

POSSIBLE

FREQUENCIES 0.3-5.0 HZ.

DATE SURVEYED JUNE 1978

APPROVED OF

Philip St. Hall
 P. G. HALLOF
 BRITISH COLUMBIA
 ENGINEER

NOTE - CONTOURS AT LOGARITHMIC INTERVALS 1,-1.5,-2,-3,-5,-7.5,-10

Expiry Date: February 25, 1979

PHOENIX GEOPHYSICS LIMITED
 INDUCED POLARIZATION AND RESISTIVITY SURVEY

RIO TINTO CANADIAN EXPL. LTD.

LUCKY JOE CREEK PROPERTY, GRID-2

DAWSON CITY AREA, YUKON TERRITORY

10S 9S 8S 7S 6S 5S 4S 3S 2S 1S 0 1N 2N 3N 4N 5N

RESISTIVITY (APP) OHM METRES

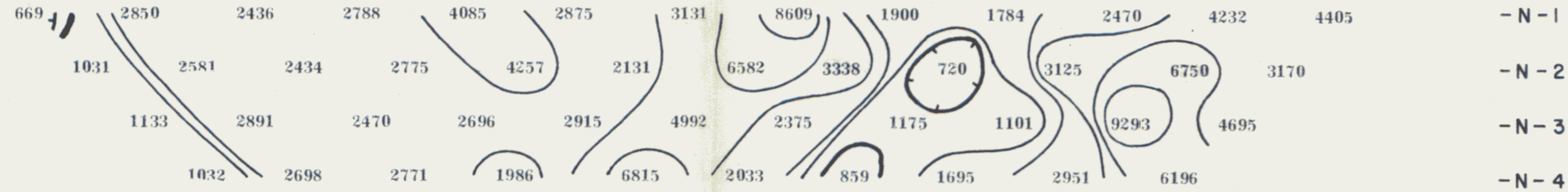

10S 9S 8S 7S 6S 5S 4S 3S 2S 1S 0 1N 2N 3N 4N 5N

METAL FACTOR (APP)

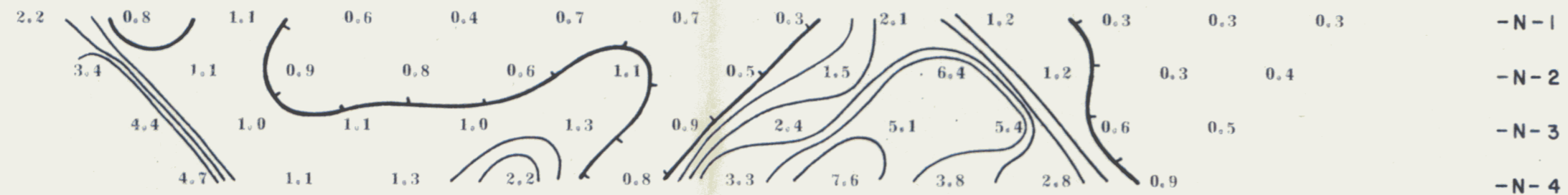

10S 9S 8S 7S 6S 5S 4S 3S 2S 1S 0 1N 2N 3N 4N 5N

FREQUENCY EFFECT (APP) IN %

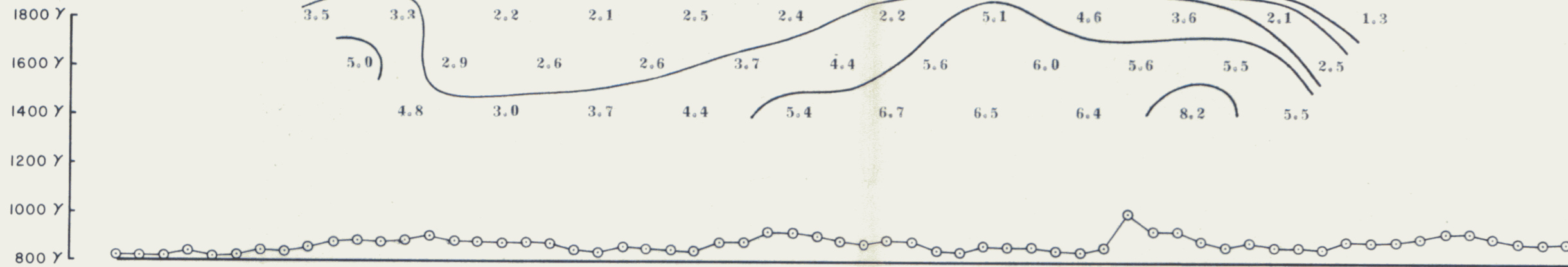
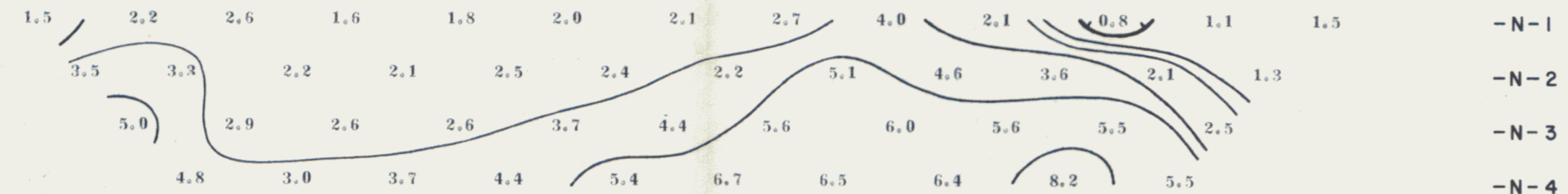

TOPOGRAPHY

CREEK

LINE NO.- 400E

ELECTRODE CONFIGURATION

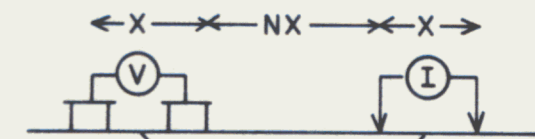

PLOTTING POINT X=100m.

SURFACE PROJECTION OF ANOMALOUS ZONE

DEFINITE
 PROBABLE
 POSSIBLE

FREQUENCIES 0.3-5.0 HZ.

DATE SURVEYED JUNE 1978

APPROVED

Philip S. Hall
 P. G. HALL
 BRITISH COLUMBIA
 ENGINEER

NOTE - CONTOURS AT LOGARITHMIC INTERVALS 1, -1.5, -2, -3, -5, -7.5, -10

DATE

Expiry Date: February 25, 1978

PHOENIX GEOPHYSICS LIMITED

INDUCED POLARIZATION AND RESISTIVITY SURVEY

RIO TINTO CANADIAN EXPL. LTD.
 LUCKY JOE CREEK PROPERTY , GRID - 2
 DAWSON CITY AREA , YUKON TERRITORY

LINE NO.- 600 E

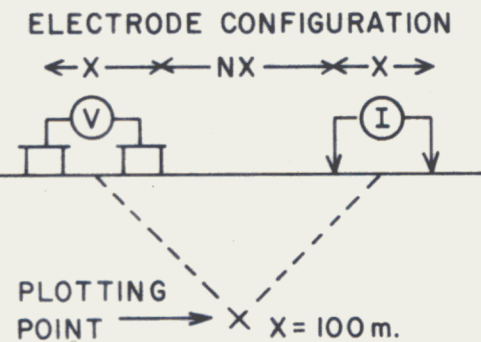

SURFACE PROJECTION OF ANOMALOUS ZONE

DEFINITE **—————**
 PROBABLE **.....**
 POSSIBLE **///////**

FREQUENCIES 0.3-5.0 HZ.

DATE SURVEYED JUNE 1978

APPROVED

Philip L. Hall
 P. L. HALL
 PROFESSIONAL ENGINEER
 BRITISH COLUMBIA

DATE

Expiry Date: February 25, 1978

NOTE - CONTOURS AT LOGARITHMIC INTERVALS 1, -1.5, -2, -3, -5, -7.5, -10

PHOENIX GEOPHYSICS LIMITED
 INDUCED POLARIZATION AND RESISTIVITY SURVEY

10S 9S 8S 7S 6S 5S 4S 3S 2S 1S 0 1N 2N 3N 4N 5N

RESISTIVITY (APP) OHM METRES

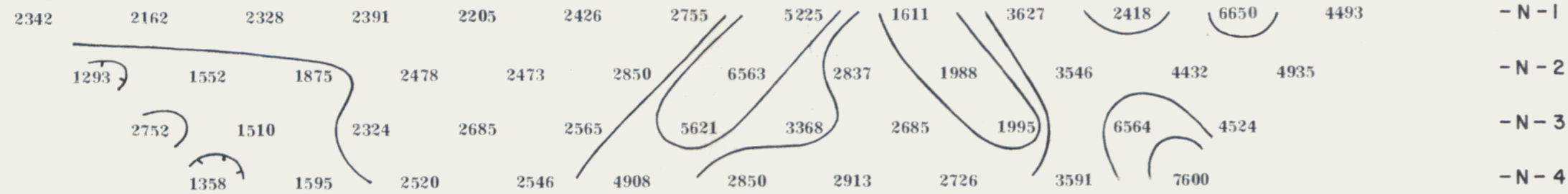

10S 9S 8S 7S 6S 5S 4S 3S 2S 1S 0 1N 2N 3N 4N 5N

METAL FACTOR (APP)

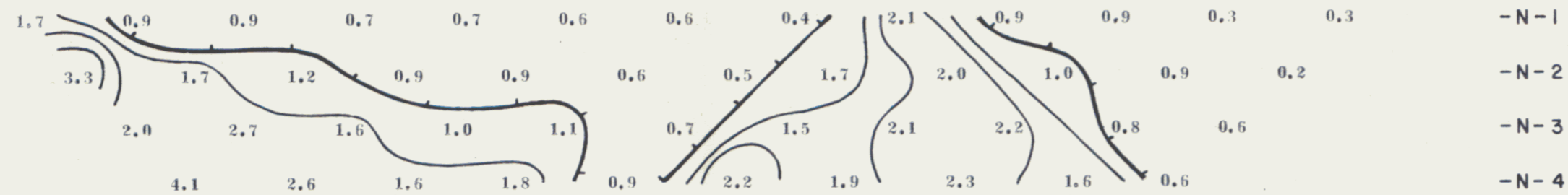

10S 9S 8S 7S 6S 5S 4S 3S 2S 1S 0 1N 2N 3N 4N 5N

FREQUENCY EFFECT (APP) IN %

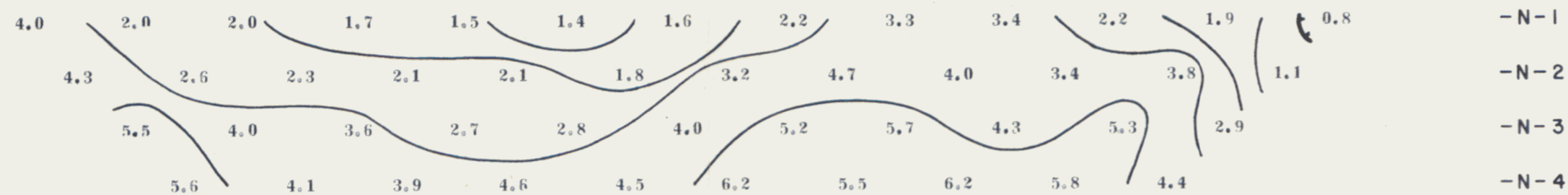

1800 Y
1600 Y
1400 Y
1200 Y
1000 Y
800 Y

TOPOGRAPHY

CREEK

RIO TINTO CANADIAN EXPL. LTD.

LUCKY JOE CREEK PROPERTY, GRID-2

DAWSON CITY AREA, YUKON TERRITORY

10S 9S 8S 7S 6S 5S 4S 3S 2S 1S 0 1N 2N 3N 4N 5N

RESISTIVITY (APP) OHM METRES

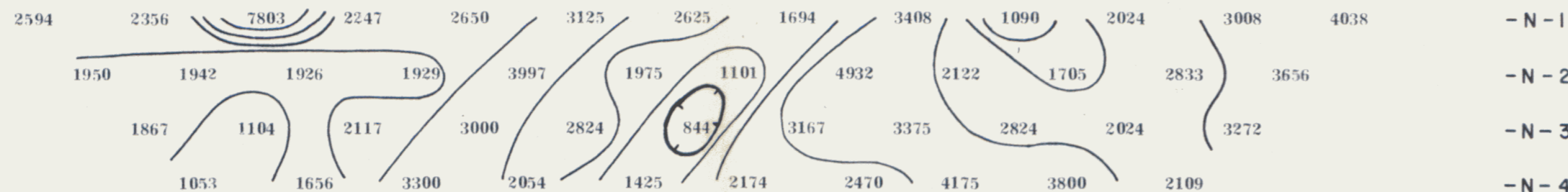

10S 9S 8S 7S 6S 5S 4S 3S 2S 1S 0 1N 2N 3N 4N 5N

METAL FACTOR (APP)

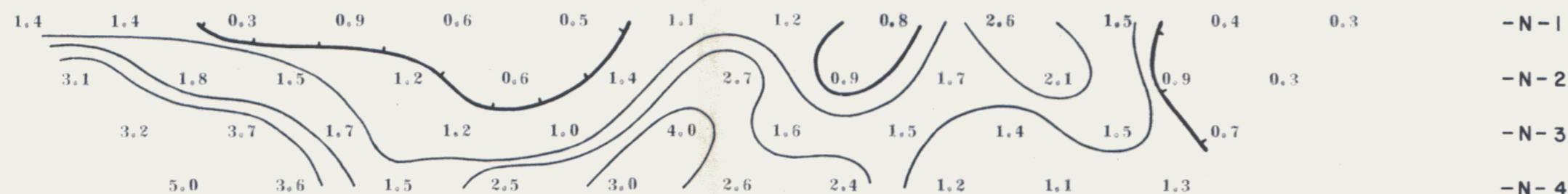

10S 9S 8S 7S 6S 5S 4S 3S 2S 1S 0 1N 2N 3N 4N 5N

FREQUENCY EFFECT (APP) IN %

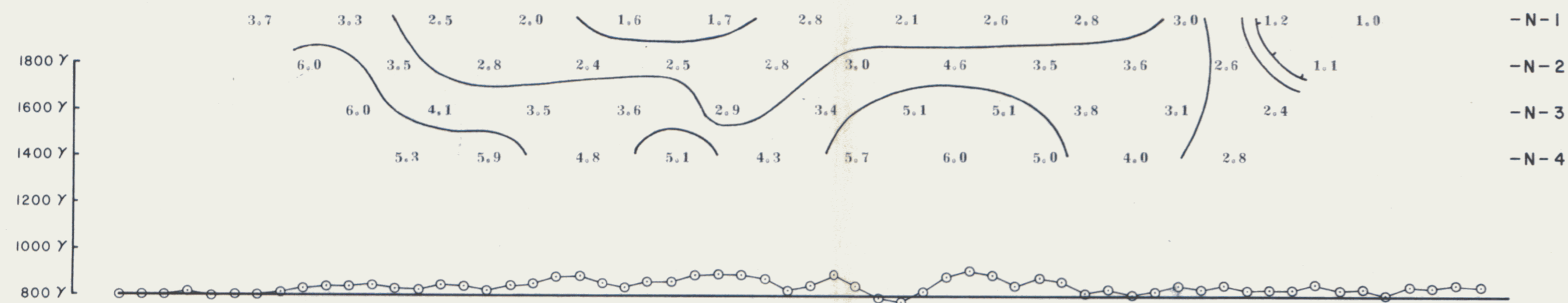

TOPOGRAPHY

CREEK

LINE NO.- 800 E

ELECTRODE CONFIGURATION

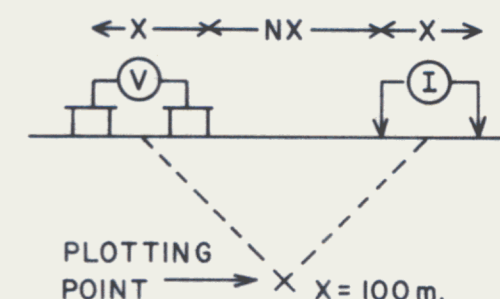

SURFACE PROJECTION OF ANOMALOUS ZONE

DEFINITE

PROBABLE

POSSIBLE

FREQUENCIES 0.3-5.0 HZ.

DATE SURVEYED JUNE 1978

APPROVED

Philip A. Hall
P. G. HALLOP
PROFESSIONAL ENGINEER
OF BRITISH COLUMBIA

DATE

NOTE - CONTOURS AT LOGARITHMIC INTERVALS 1, -1.5, -2, -3, -5, -7.5, -10

Expiry Date: February 25, 1979

PHOENIX GEOPHYSICS LIMITED

INDUCED POLARIZATION AND RESISTIVITY SURVEY

RIO TINTO CANADIAN EXPL. LTD.
 LUCKY JOE CREEK PROPERTY, GRID - 2
 DAWSON CITY AREA, YUKON TERRITORY

10S 9S 8S 7S 6S 5S 4S 3S 2S 1S 0 1N 2N 3N 4N 5N

RESISTIVITY (APP) OHM METRES

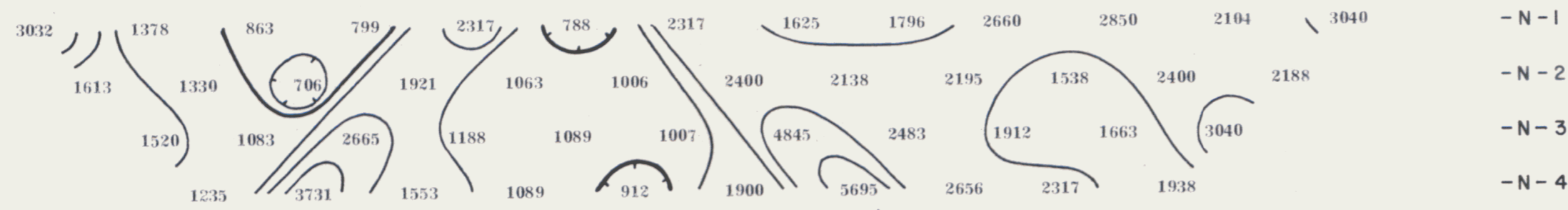

-N-1
 -N-2
 -N-3
 -N-4

10S 9S 8S 7S 6S 5S 4S 3S 2S 1S 0 1N 2N 3N 4N 5N

METAL FACTOR (APP)

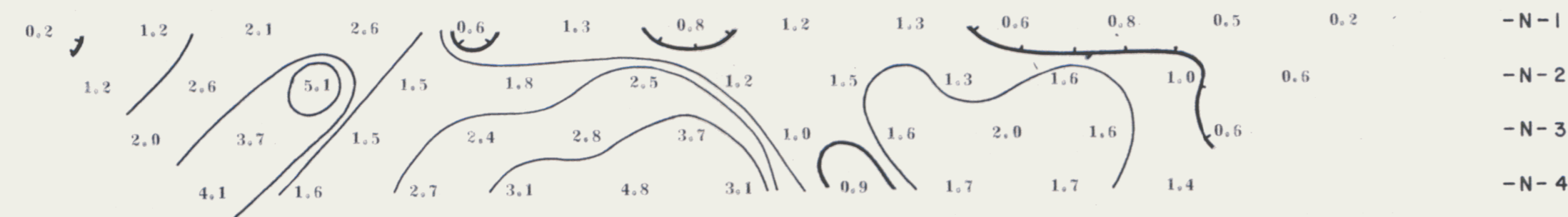

-N-1
 -N-2
 -N-3
 -N-4

10S 9S 8S 7S 6S 5S 4S 3S 2S 1S 0 1N 2N 3N 4N 5N

FREQUENCY EFFECT (APP) IN %

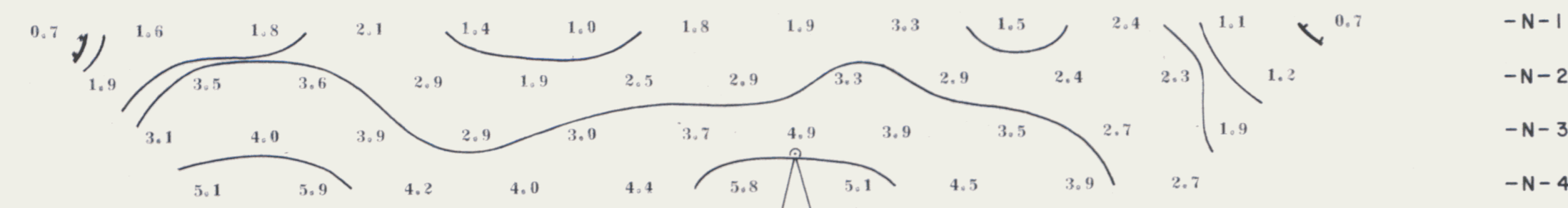

-N-1
 -N-2
 -N-3
 -N-4

1800 Y
 1600 Y
 1400 Y
 1200 Y
 1000 Y
 800 Y

TOPOGRAPHY

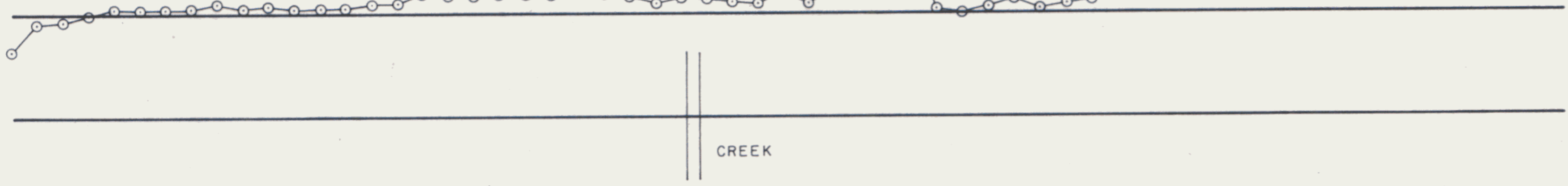

LINE NO.- 1000E

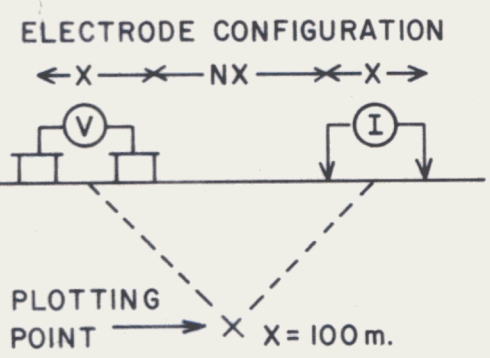

SURFACE PROJECTION OF ANOMALOUS ZONE
 DEFINITE —————
 PROBABLE ·········
 POSSIBLE - - - - -

FREQUENCIES 0.3-5.0 HZ.

DATE SURVEYED JUNE 1978

PROFESSIONAL
 PROVINCE OF
 APPROVED OF
Philip S. Hall
 P. G. HALL
 BRITISH COLUMBIA
 ENGINEER
 DATE

NOTE - CONTOURS AT LOGARITHMIC INTERVALS 1, -1.5, -2, -3, -5, -7.5, -10

Expiry Date: February 25, 1979

PHOENIX GEOPHYSICS LIMITED
 INDUCED POLARIZATION AND RESISTIVITY SURVEY

RIO TINTO CANADIAN EXPL. LTD.
 LUCKY JOE CREEK PROPERTY, GRID-2
 DAWSON CITY AREA, YUKON TERRITORY

LINE NO.- 1200E

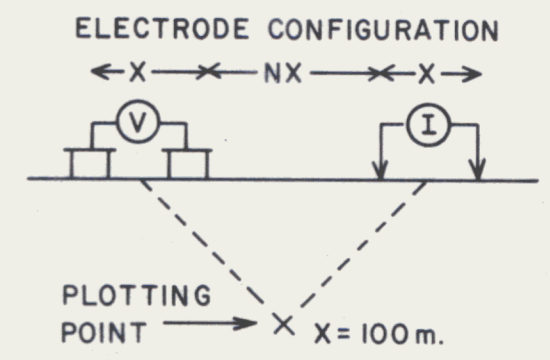

SURFACE PROJECTION OF ANOMALOUS ZONE

DEFINITE

PROBABLE

POSSIBLE

FREQUENCIES 0.3-5.0 HZ.

DATE SURVEYED JUNE 1978

NOTE - CONTOURS AT LOGARITHMIC INTERVALS 1, -1.5, -2, -3, -5, -7.5, -10

APPROVED OF

 P. G. HALLOF
 BRITISH COLUMBIA
 ENGINEER
 DATE _____
 Expiry Date: February 25, 1979

PHOENIX GEOPHYSICS LIMITED
 INDUCED POLARIZATION AND RESISTIVITY SURVEY

10S 9S 8S 7S 6S 5S 4S 3S 2S 1S 0 1N 2N 3N 4N 5N

RESISTIVITY (APP) OHM METRES

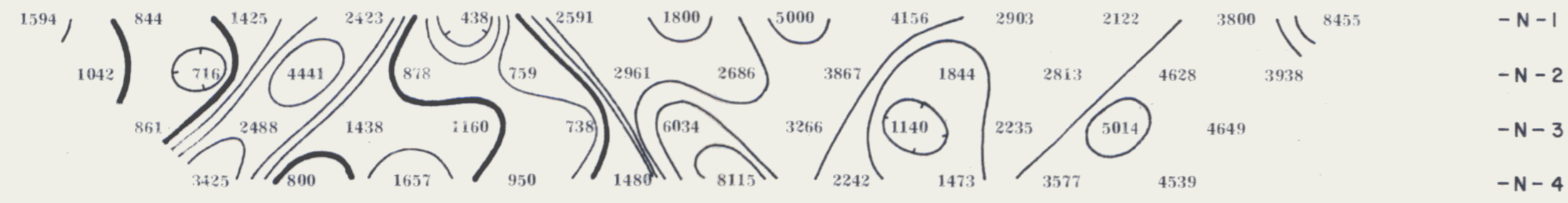

10S 9S 8S 7S 6S 5S 4S 3S 2S 1S 0 1N 2N 3N 4N 5N

METAL FACTOR (APP)

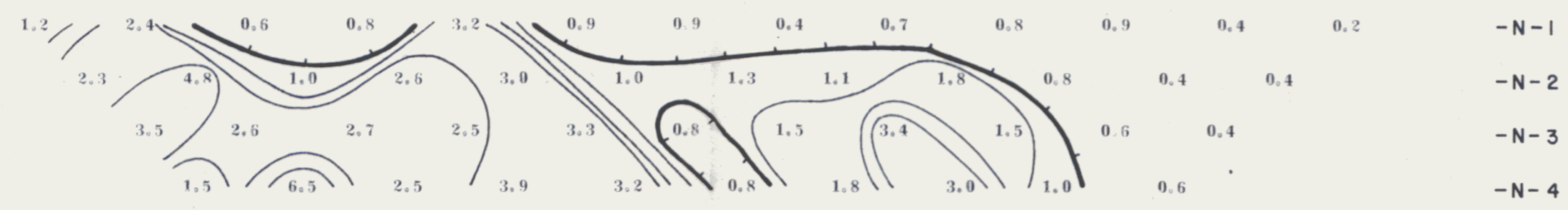

10S 9S 8S 7S 6S 5S 4S 3S 2S 1S 0 1N 2N 3N 4N 5N

FREQUENCY EFFECT (APP) IN %

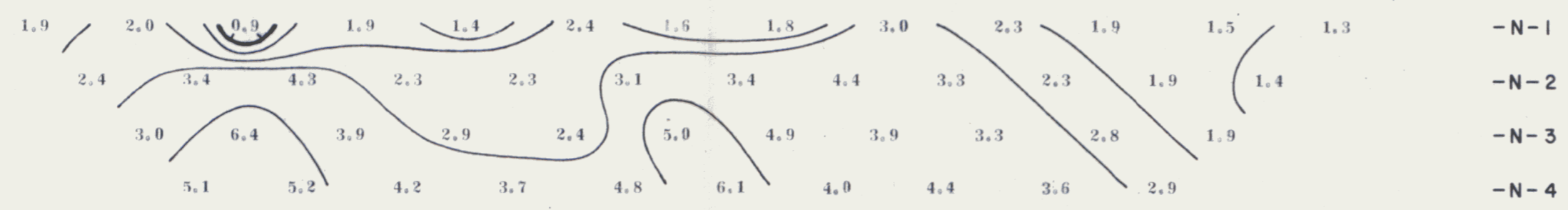

1800 Y
1600 Y
1400 Y
1200 Y
1000 Y
800 Y

TOPOGRAPHY

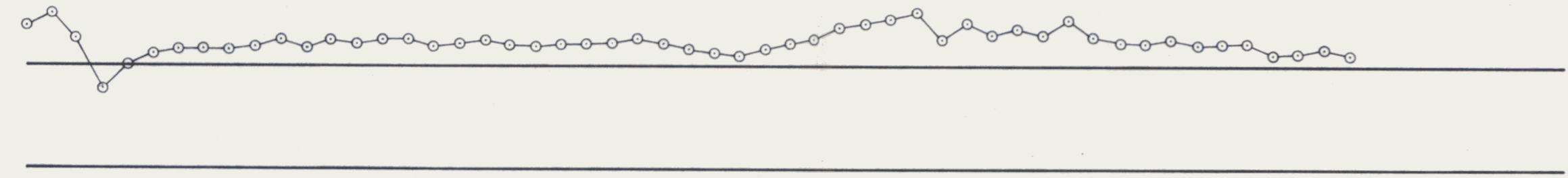

RIO TINTO CANADIAN EXPL. LTD.

LUCKY JOE CREEK PROPERTY, GRID - 3

DAWSON CITY AREA, YUKON TERRITORY

LINE NO. - 600 W

ELECTRODE CONFIGURATION

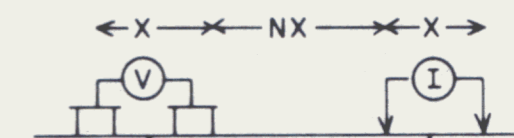

PLOTTING POINT X=100m.

SURFACE PROJECTION OF ANOMALOUS ZONE

DEFINITE
 PROBABLE
 POSSIBLE

FREQUENCIES 0.3 - 5.0 HZ.

DATE SURVEYED JUNE 1978

APPROVED OF

Philip G. Hallop
 P. G. HALLOP
 BRITISH COLUMBIA
 ENGINEER

NOTE - CONTOURS AT LOGARITHMIC INTERVALS 1, -1.5, -2, -3, -5, -7.5, -10

Expiry Date: February 25, 1979

PHOENIX GEOPHYSICS LIMITED

INDUCED POLARIZATION AND RESISTIVITY SURVEY

5S 4S 3S 2S 1S 0 1N 2N 3N 4N 5N 6N 7N 8N 9N 10N

RESISTIVITY (APP) OHM METRES

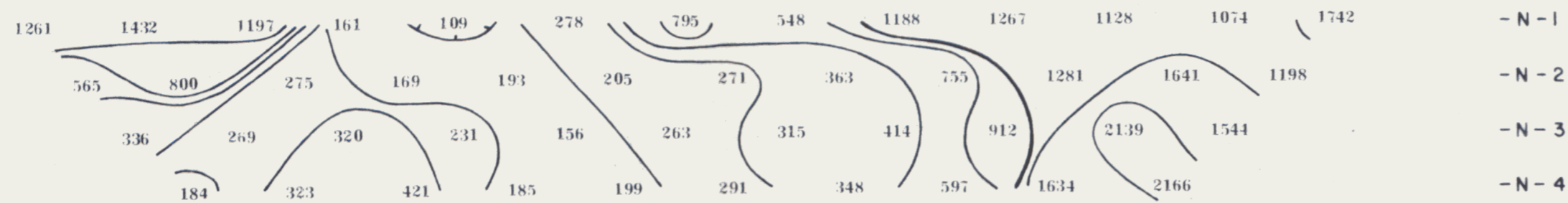

5S 4S 3S 2S 1S 0 1N 2N 3N 4N 5N 6N 7N 8N 9N 10N

METAL FACTOR (APP)

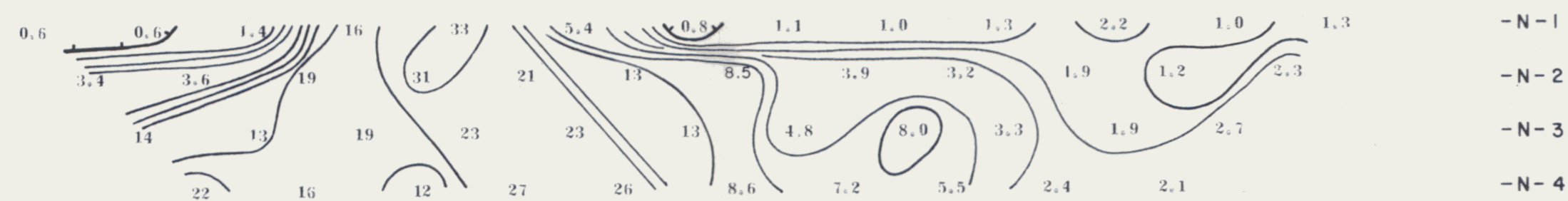

5S 4S 3S 2S 1S 0 1N 2N 3N 4N 5N 6N 7N 8N 9N 10N

FREQUENCY EFFECT (APP) IN %

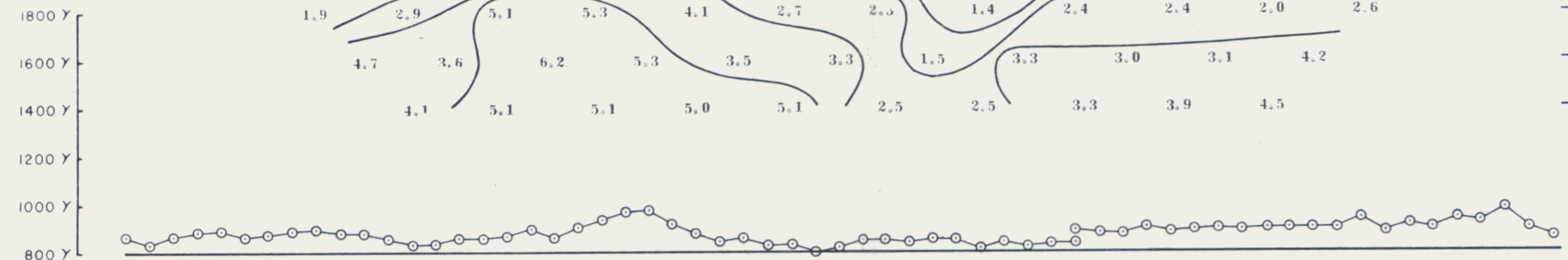
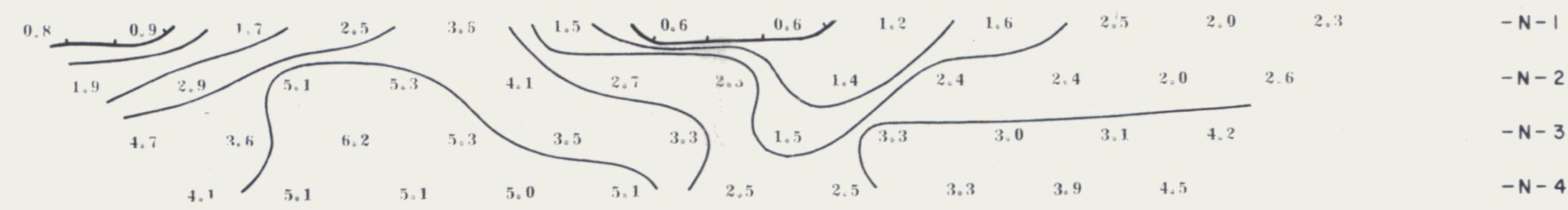

TOPOGRAPHY



RIO TINTO CANADIAN EXPL. LTD.
 LUCKY JOE CREEK PROPERTY , GRID - 3
 DAWSON CITY AREA , YUKON TERRITORY

5S 4S 3S 2S 1S 0 1N 2N 3N 4N 5N 6N 7N 8N 9N 10N

RESISTIVITY (APP) OHM METRES

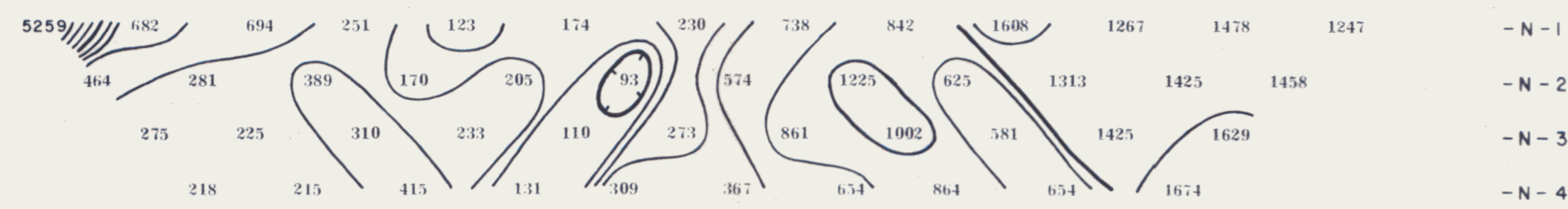

5S 4S 3S 2S 1S 0 1N 2N 3N 4N 5N 6N 7N 8N 9N 10N

METAL FACTOR (APP)

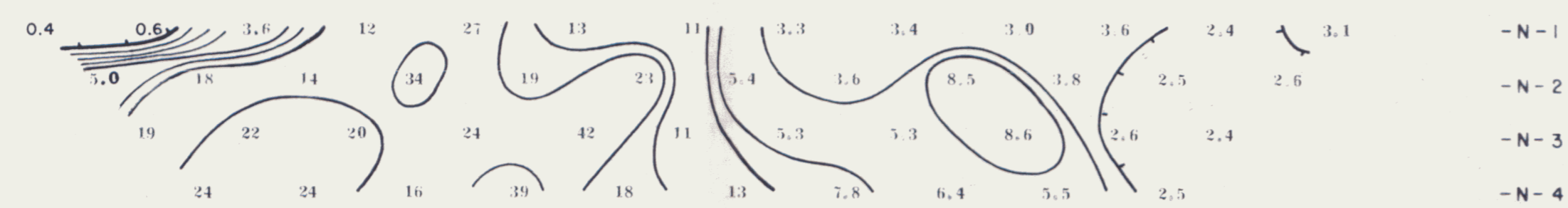

5S 4S 3S 2S 1S 0 1N 2N 3N 4N 5N 6N 7N 8N 9N 10N

FREQUENCY EFFECT (APP) IN %

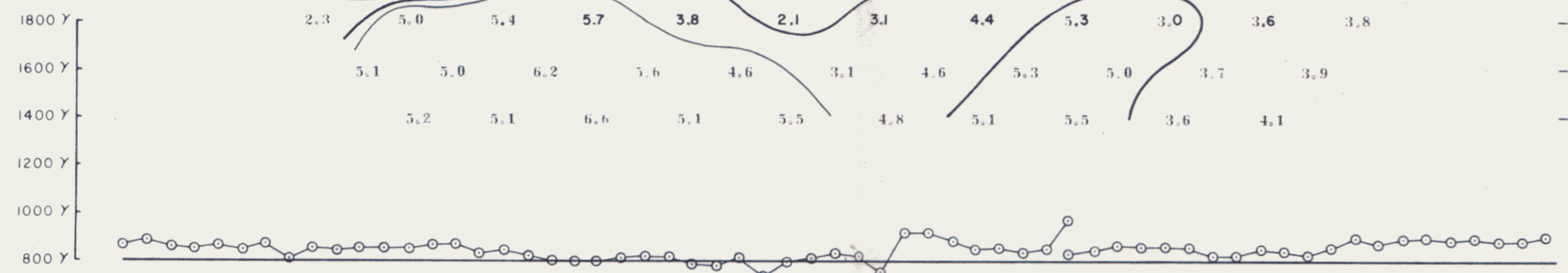
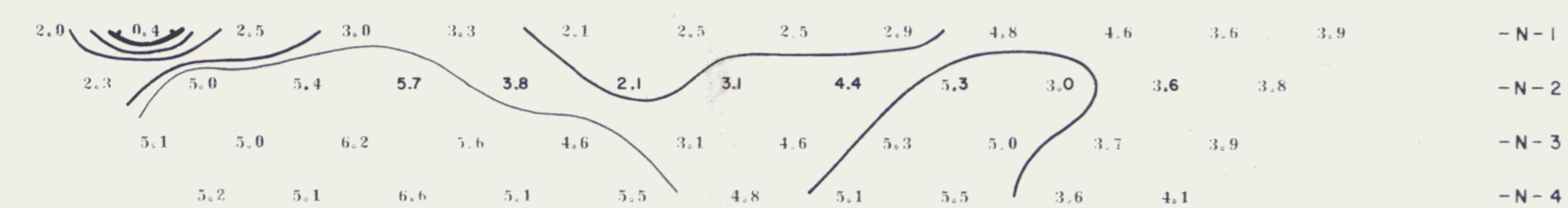

LINE NO.- 400W

ELECTRODE CONFIGURATION

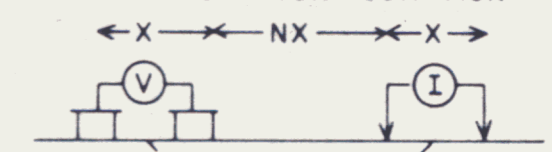

PLOTTING POINT X = 100 m.

SURFACE PROJECTION OF ANOMALOUS ZONE

DEFINITE
 PROBABLE
 POSSIBLE

FREQUENCIES 0.3 - 5.0 HZ.

DATE SURVEYED JUNE 1978

APPROVED

Philip S. Hall
 P. G. HALLOP
 BRITISH COLUMBIA ENGINEER

NOTE - CONTOURS AT LOGARITHMIC INTERVALS 1, -1.5, -2, -3, -5, -7.5, -10

DATE

Expiry Date: February 25, 1979

PHOENIX GEOPHYSICS LIMITED
 INDUCED POLARIZATION AND RESISTIVITY SURVEY

RIO TINTO CANADIAN EXPL. LTD.
 LUCKY JOE CREEK PROPERTY , GRID - 3
 DAWSON CITY AREA , YUKON TERRITORY

LINE NO.- 200W

ELECTRODE CONFIGURATION

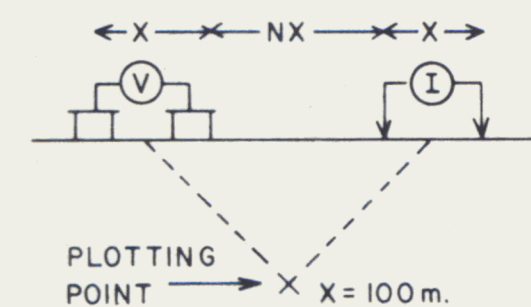

SURFACE PROJECTION OF ANOMALOUS ZONE

DEFINITE
 PROBABLE
 POSSIBLE

FREQUENCIES 0.3-5.0 HZ.

DATE SURVEYED JUNE 1978

APPROVED OF

 CHIEF OF PARTY
 BRITISH COLUMBIA
 PROFESSIONAL ENGINEER
 DATE _____

NOTE - CONTOURS AT LOGARITHMIC INTERVALS 1, -1.5, -2, -3, -5, -7.5, -10

Expiry Date: February 25, 1979

PHOENIX GEOPHYSICS LIMITED
 INDUCED POLARIZATION AND RESISTIVITY SURVEY

5S 4S 3S 2S 1S 0 1N 2N 3N 4N 5N 6N 7N 8N 9N 10N

RESISTIVITY (APP) OHM METRES

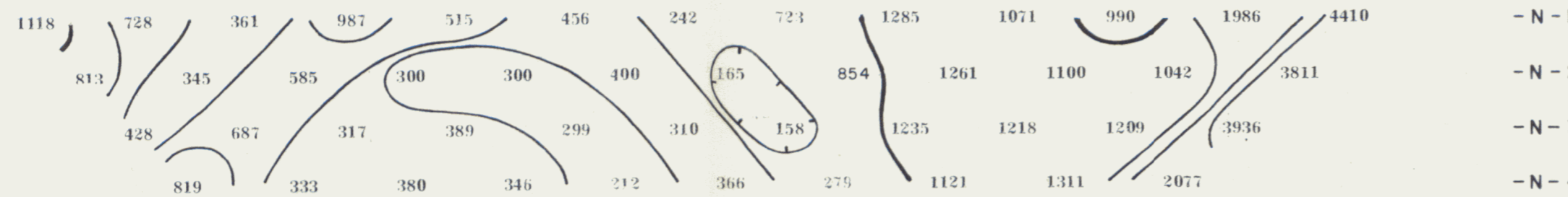

5S 4S 3S 2S 1S 0 1N 2N 3N 4N 5N 6N 7N 8N 9N 10N

METAL FACTOR (APP)

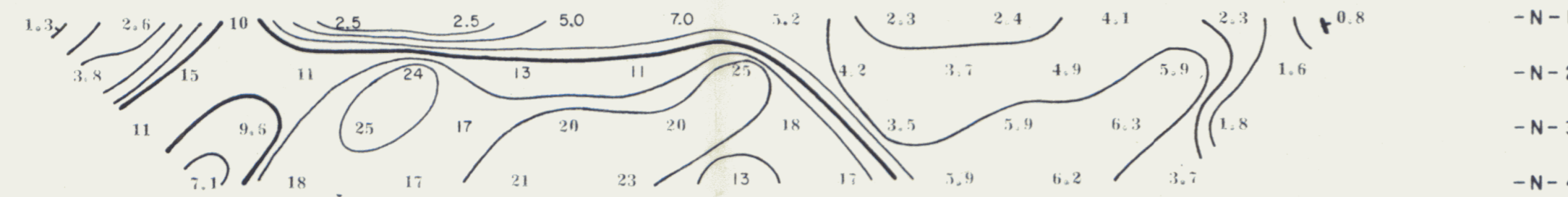

5S 4S 3S 2S 1S 0 1N 2N 3N 4N 5N 6N 7N 8N 9N 10N

FREQUENCY EFFECT (APP) IN %

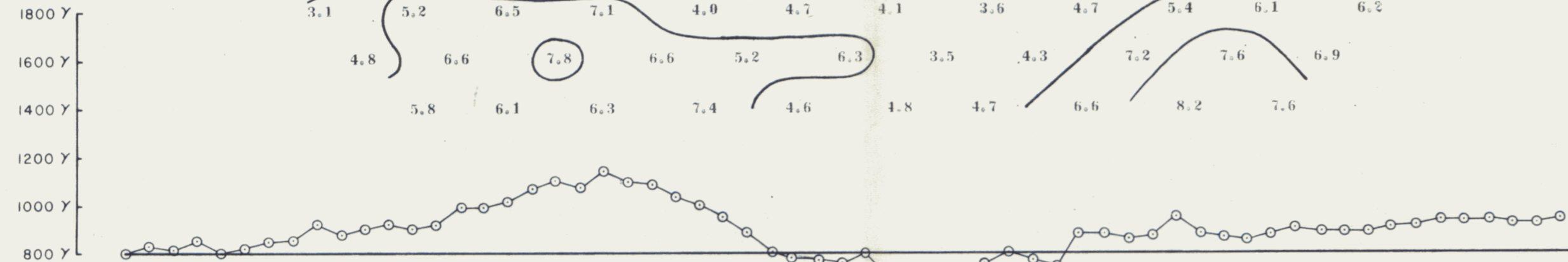
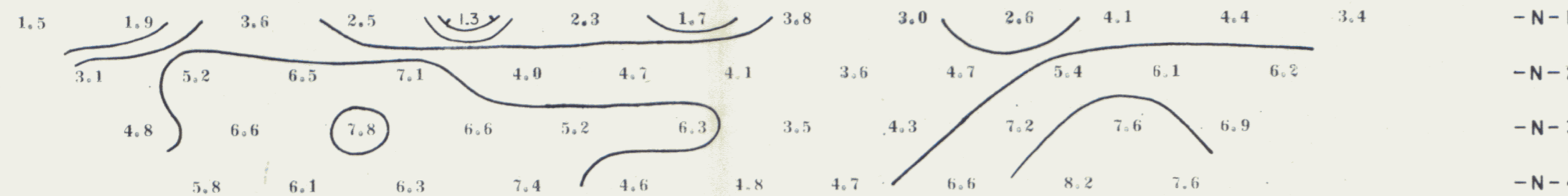

TOPOGRAPHY

CREEK

RIO TINTO CANADIAN EXPL. LTD.

LUCKY JOE CREEK PROPERTY, GRID-3

DAWSON CITY AREA, YUKON TERRITORY

5S 4S 3S 2S 1S 0 1N 2N 3N 4N 5N 6N 7N 8N 9N 10N

RESISTIVITY (APP) OHM METRES

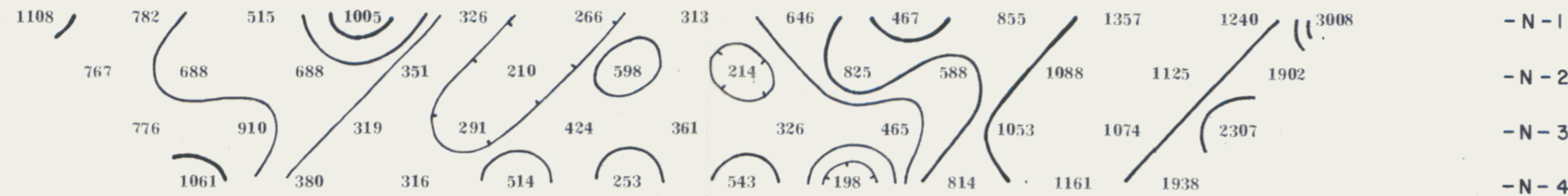

5S 4S 3S 2S 1S 0 1N 2N 3N 4N 5N 6N 7N 8N 9N 10N

METAL FACTOR (APP)

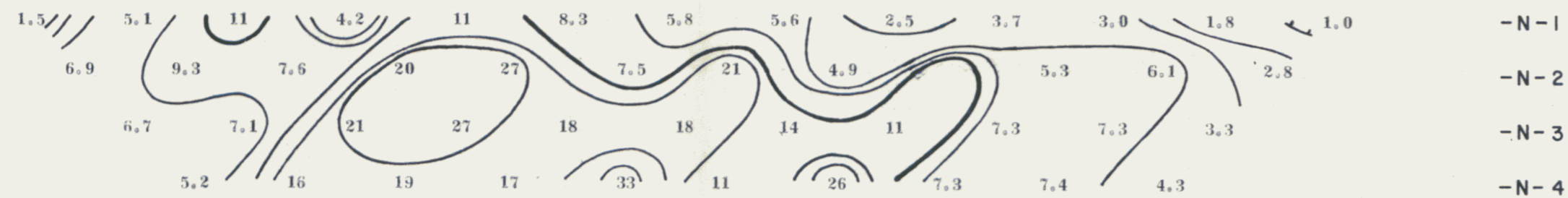

5S 4S 3S 2S 1S 0 1N 2N 3N 4N 5N 6N 7N 8N 9N 10N

FREQUENCY EFFECT (APP) IN %

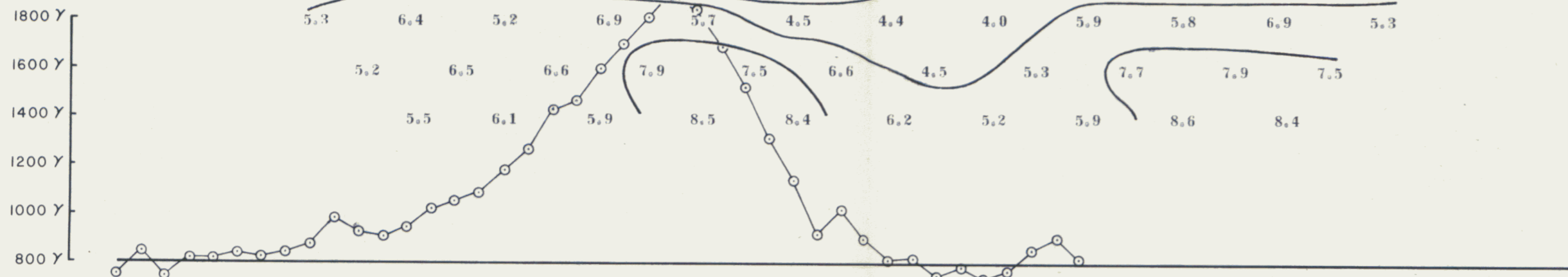
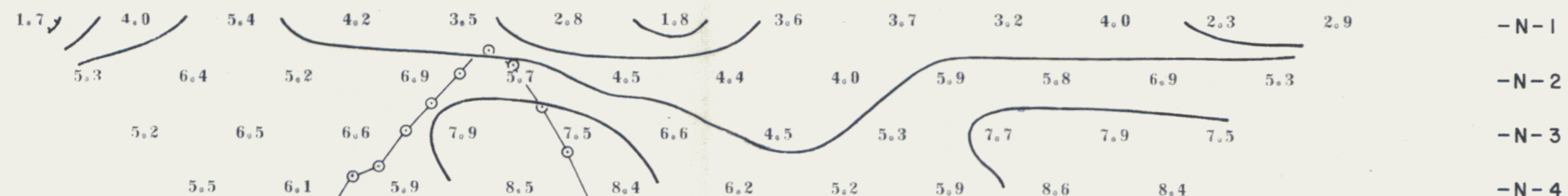

TOPOGRAPHY

LINE NO.- 00

ELECTRODE CONFIGURATION

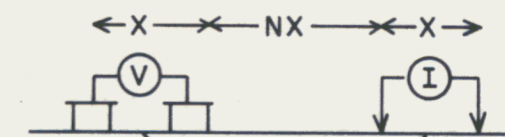

PLOTTING POINT X X = 100 m.

SURFACE PROJECTION OF ANOMALOUS ZONE

DEFINITE
 PROBABLE
 POSSIBLE

FREQUENCIES 0.3-5.0 HZ.

DATE SURVEYED JUNE 1978

APPROVED

Philip S. Hall
 P. G. HALL
 BRITISH COLUMBIA
 ENGINEER

NOTE - CONTOURS AT LOGARITHMIC INTERVALS 1, -1.5, -2, -3, -5, -7.5, -10

DATE

Expiry Date: February 25, 1979

PHOENIX GEOPHYSICS LIMITED

INDUCED POLARIZATION AND RESISTIVITY SURVEY

RIO TINTO CANADIAN EXPL. LTD.
 LUCKY JOE CREEK PROPERTY, GRID-3
 DAWSON CITY AREA, YUKON TERRITORY

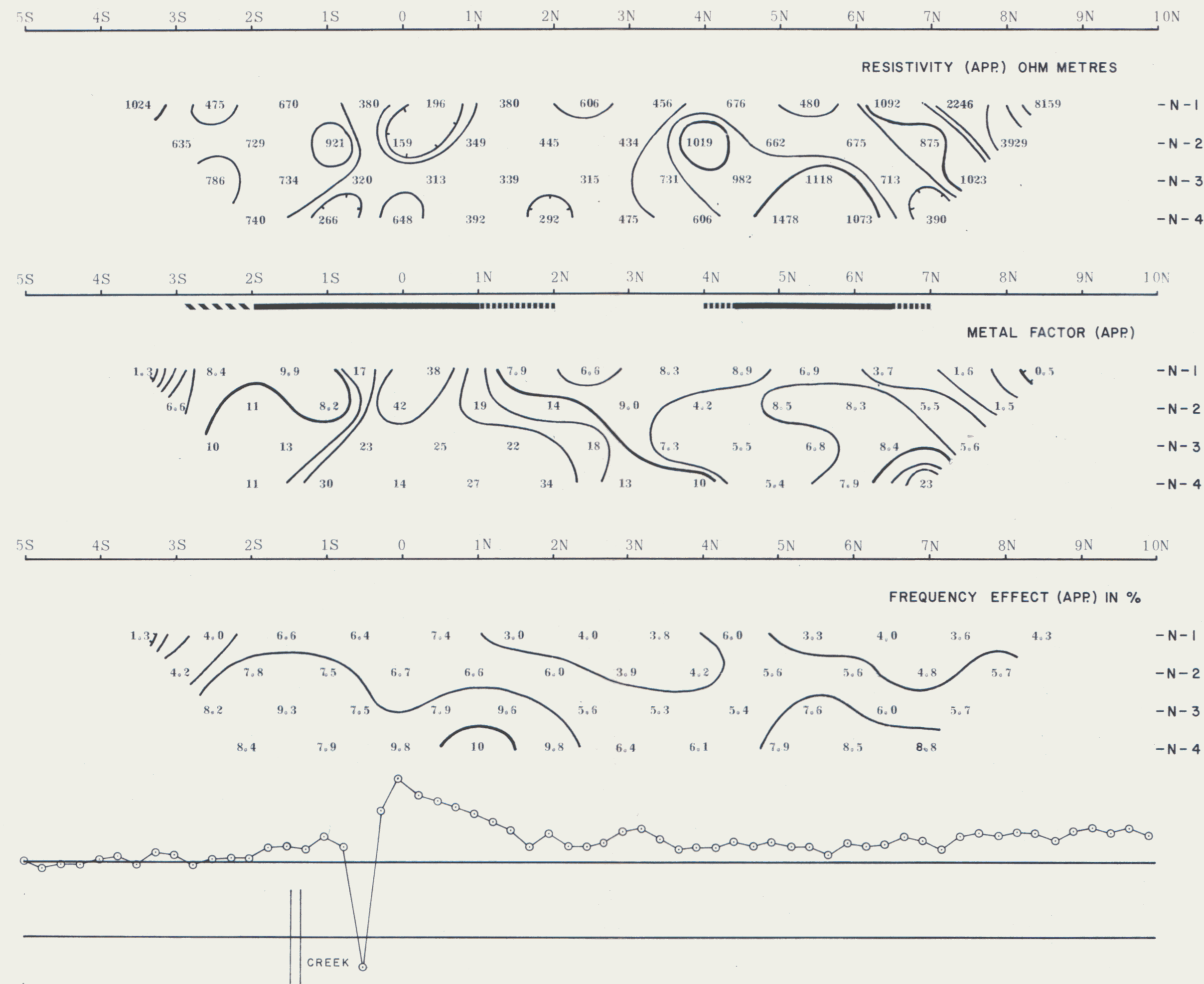

LINE NO.- 200E

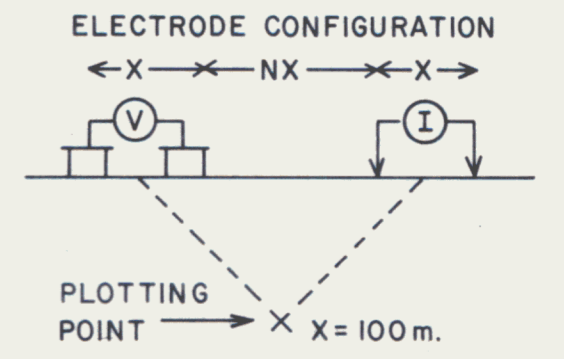

SURFACE PROJECTION OF ANOMALOUS ZONE

DEFINITE

PROBABLE

POSSIBLE

FREQUENCIES 0.3-5.0 HZ.

DATE SURVEYED JUNE 1978

APPROVED OF

 P. G. HALLOF
 BRITISH COLUMBIA
 ENGINEER

NOTE - CONTOURS AT LOGARITHMIC INTERVALS 1, -1.5, -2, -3, -5, -7.5, -10

Expiry Date: February 25, 1979

PHOENIX GEOPHYSICS LIMITED
 INDUCED POLARIZATION AND RESISTIVITY SURVEY

RIO TINTO CANADIAN EXPL. LTD.
 LUCKY JOE CREEK PROPERTY , GRID - 3
 DAWSON CITY AREA , YUKON TERRITORY

5S 4S 3S 2S 1S 0 1N 2N 3N 4N 5N 6N 7N 8N 9N 10N

RESISTIVITY (APP) OHM METRES

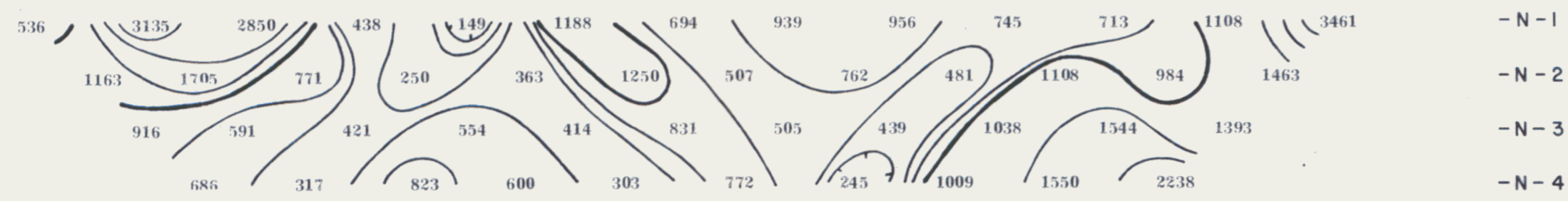

5S 4S 3S 2S 1S 0 1N 2N 3N 4N 5N 6N 7N 8N 9N 10N

METAL FACTOR (APP)

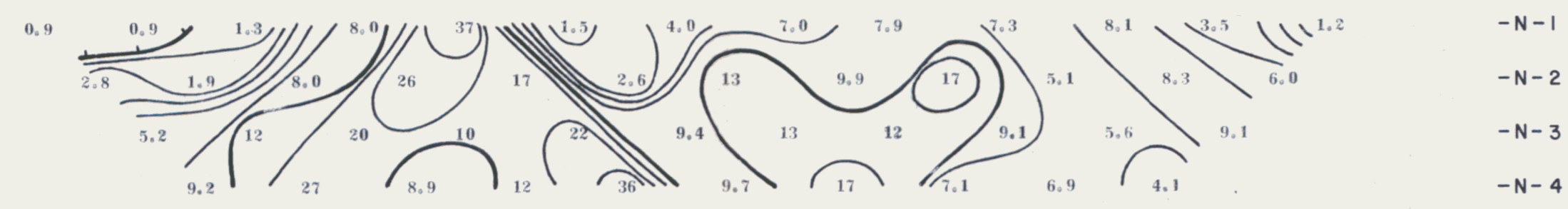

5S 4S 3S 2S 1S 0 1N 2N 3N 4N 5N 6N 7N 8N 9N 10N

FREQUENCY EFFECT (APP) IN %

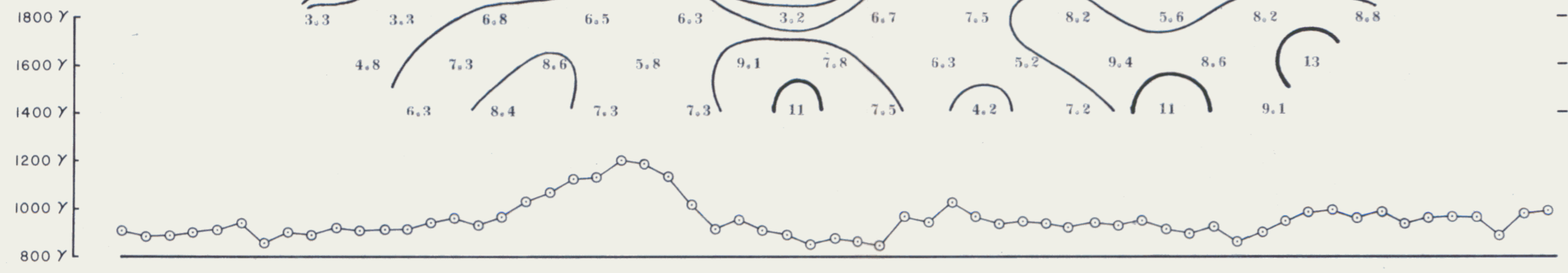
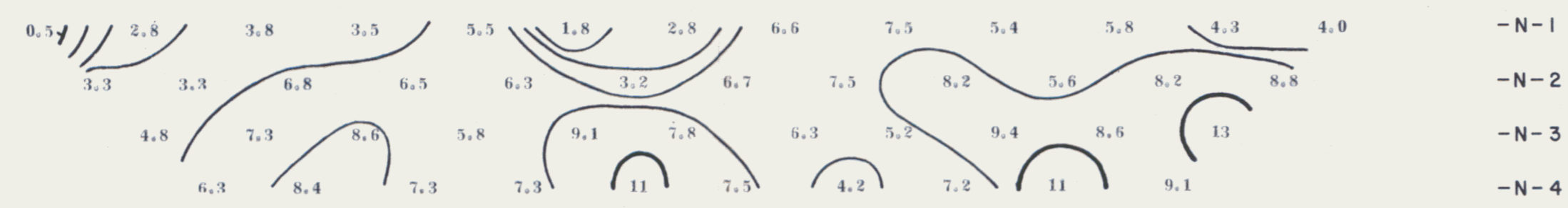

TOPOGRAPHY

CREEK

LINE NO.- 400E

ELECTRODE CONFIGURATION

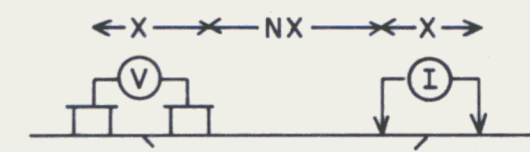

PLOTTING POINT X = 100m.

SURFACE PROJECTION OF ANOMALOUS ZONE

DEFINITE
 PROBABLE
 POSSIBLE

FREQUENCIES 0.3-5.0 HZ.

DATE SURVEYED JUNE 1978

APPROVED

Philip L. Hallop
 P.G. HALLOP
 BRITISH COLUMBIA
 ENGINEER

DATE

Expiry Date: February 25, 1978

NOTE - CONTOURS AT LOGARITHMIC INTERVALS 1, -1.5, -2, -3, -5, -7.5, -10

PHOENIX GEOPHYSICS LIMITED

INDUCED POLARIZATION AND RESISTIVITY SURVEY

RIO TINTO CANADIAN EXPL. LTD.
 LUCKY JOE CREEK PROPERTY, GRID - 3
 DAWSON CITY AREA, YUKON TERRITORY

LINE NO.- 600E

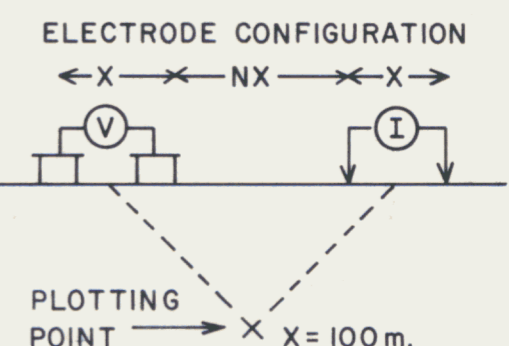

SURFACE PROJECTION OF ANOMALOUS ZONE

DEFINITE

PROBABLE

POSSIBLE

FREQUENCIES 0.3-5.0 HZ.

DATE SURVEYED JUNE 1978

APPROVED

Philip L. Hall
 P. G. HALL
 BRITISH COLUMBIA
 ENGINEER

NOTE - CONTOURS AT LOGARITHMIC INTERVALS 1, -1.5, -2, -3, -5, -7.5, -10

DATE

Expiry Date: February 25, 1979

PHOENIX GEOPHYSICS LIMITED
 INDUCED POLARIZATION AND RESISTIVITY SURVEY

5S 4S 3S 2S 1S 0 1N 2N 3N 4N 5N 6N 7N 8N 9N 10N

RESISTIVITY (APP) OHM METRES

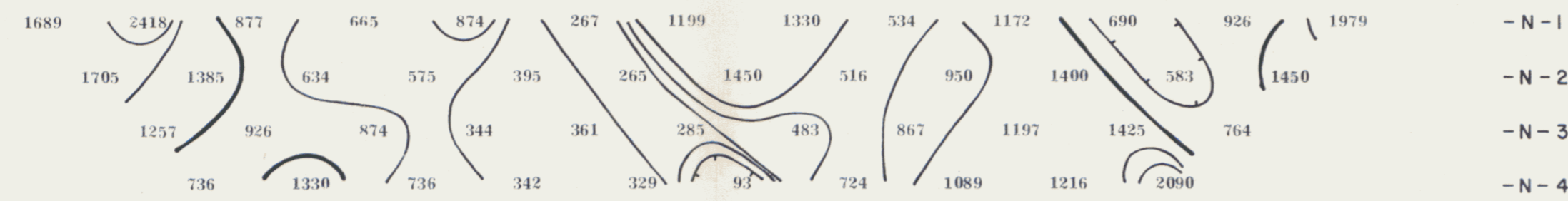

5S 4S 3S 2S 1S 0 1N 2N 3N 4N 5N 6N 7N 8N 9N 10N

METAL FACTOR (APP)

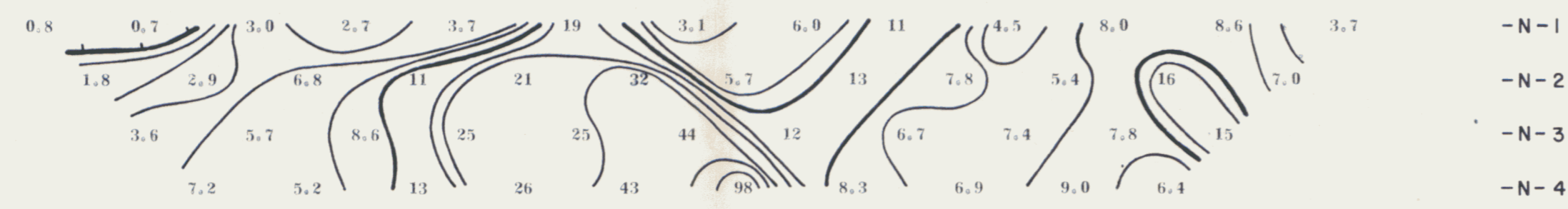

5S 4S 3S 2S 1S 0 1N 2N 3N 4N 5N 6N 7N 8N 9N 10N

FREQUENCY EFFECT (APP) IN %

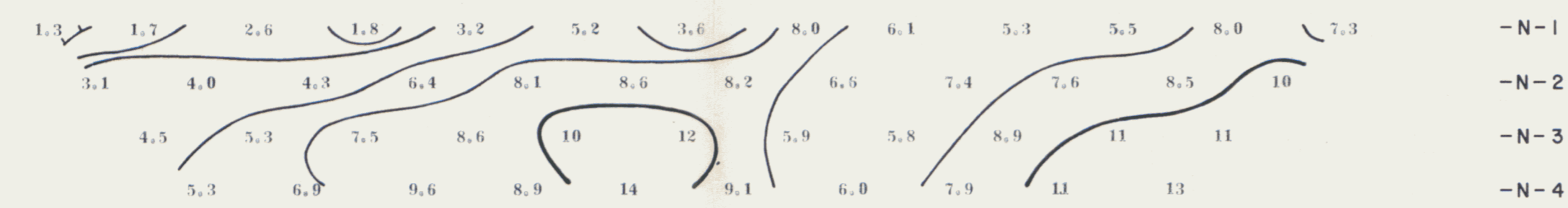

1800 Y
1600 Y
1400 Y
1200 Y
1000 Y
800 Y

TOPOGRAPHY

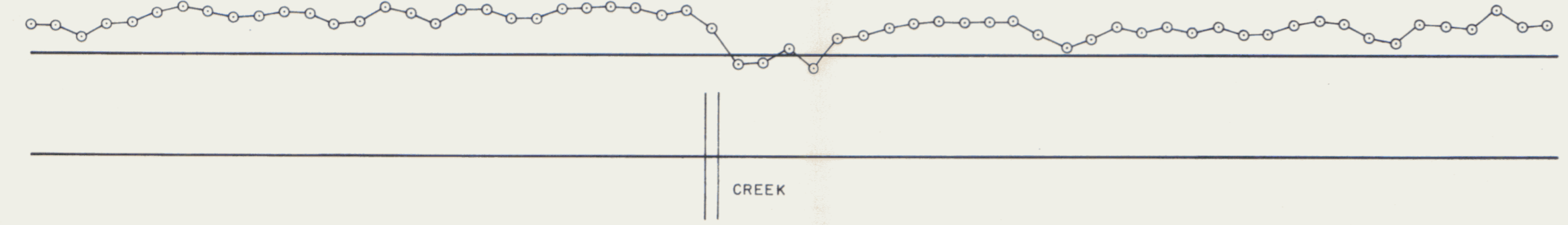

RIO TINTO CANADIAN EXPL. LTD.
 LUCKY JOE CREEK PROPERTY , GRID - 3
 DAWSON CITY AREA , YUKON TERRITORY

5S 4S 3S 2S 1S 0 1N 2N 3N 4N 5N 6N 7N 8N 9N 10N

RESISTIVITY (APP) OHM METRES

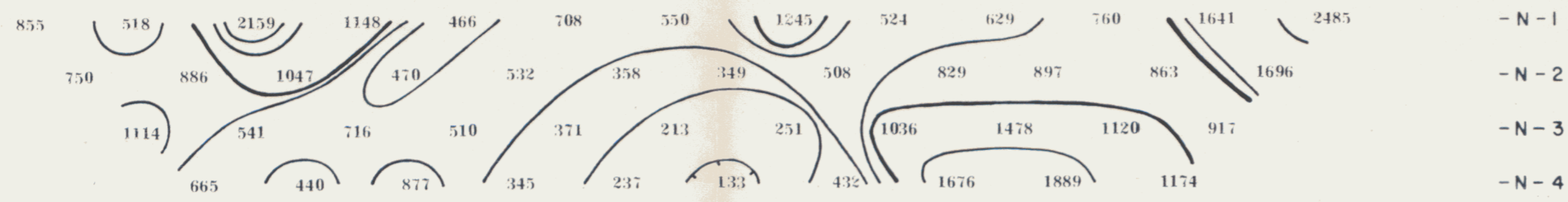

5S 4S 3S 2S 1S 0 1N 2N 3N 4N 5N 6N 7N 8N 9N 10N

METAL FACTOR (APP)

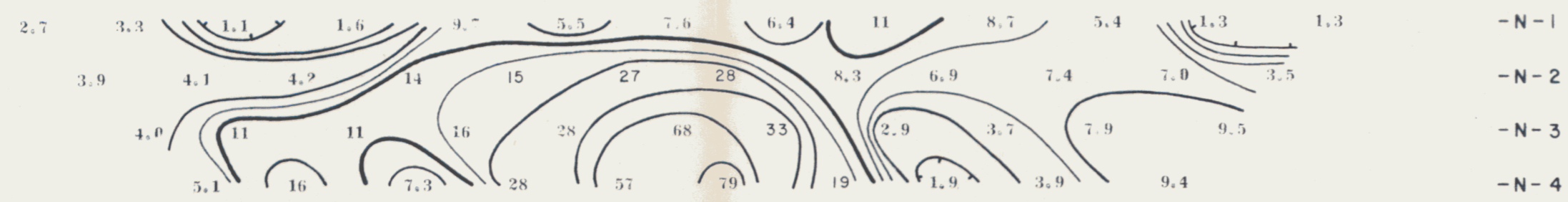

5S 4S 3S 2S 1S 0 1N 2N 3N 4N 5N 6N 7N 8N 9N 10N

FREQUENCY EFFECT (APP) IN %

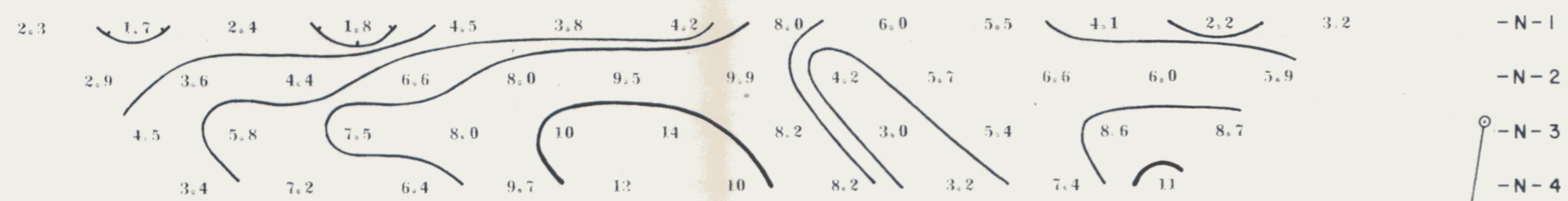

1800 Y
1600 Y
1400 Y
1200 Y
1000 Y
800 Y



TOPOGRAPHY



LINE NO.- 800E

ELECTRODE CONFIGURATION

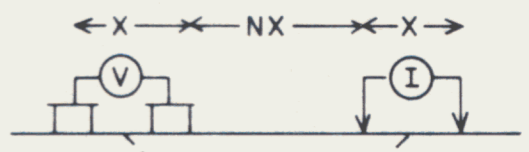

PLOTTING POINT X = 100m.

SURFACE PROJECTION OF ANOMALOUS ZONE

- DEFINITE
- PROBABLE
- POSSIBLE

FREQUENCIES 0.3-5.0 HZ.

DATE SURVEYED 1978

APPROVED

Philip H. Hallop
 P. HALLOP
 BRITISH COLUMBIA
 ENGINEER

NOTE - CONTOURS AT LOGARITHMIC INTERVALS 1, -1.5, -2, -3, -5, -7.5, -10

DATE

Expiry Date: February 25, 1979

PHOENIX GEOPHYSICS LIMITED
 INDUCED POLARIZATION AND RESISTIVITY SURVEY