

D. C. MALCOLM, P. ENG.
CONSULTING GEOLOGIST

TELEPHONE 731-7208

2290 WEST 23RD AVENUE
VANCOUVER 8, B.C.

March 2, 1973

Scurry Rainbow Oil Limited
Mining Division
Calgary, Alberta

Dear Sirs:-

The Clark deposit is unique in having high silver values in a lead-zinc replacement. The lower Cambrian disturbed limestone belt in which it occurs has been extensively explored from Washington to the Pelly River in the Yukon and contains most of Canada's silver-lead-zinc producers.

The McQuesten-Beaver River belt is known to contain 7 unexplored or partly explored replacements. It has been well mapped geologically and extensively sampled by Government geochemical and geophysical surveys. It should be explored.

The key to finding mines in this environment is in geological understanding of the deposits.

I would recommend detailed studies and geological mapping of the main Clark deposit and of galena showings which outcrop on Line 8 west 12 south, 52 west 16 north and float at 7 east on the base line. These studies should be extended to the Tom Group and to the replacements on the Beaver River.

I would recommend underground exploration on the main deposit to allow cheaper work on the downward extensions of the replacement and the vein fault which controls it.

GENERAL EXPLORATION

The Beltian or upper Pre-Cambrian and lower Cambrian limestone belt has been extensively searched for silver-lead-zinc deposits in British Columbia and the Yukon Territories for many years. This belt contains most of the silver-lead-zinc mines in Canada.

The Clark deposit is in this same belt in the Mayo District and contains higher silver values than is usual in these replacements. There are six other replacements in the district but despite this and extensive geochemical, geophysical and geological surveys by the Government the area is relatively unexplored.

With a camp at the Clark deposit using aircraft and helicopters based at Mayo the Clark Lake limestones could be readily explored for new replacements.

PROPERTY EXPLORATION

The Clark deposit is a silver-lead-zinc-replacement in brecciated limestone controlled by one or more vein faults. The limestone is folded and overlain by quartzite. The detailed geology of the claims is not known.

The replacement is very irregular and difficult to explore from the surface due to the topography, the quartzite, the lack of surface outcrops of limestone and the oxidized condition of the sulphides at the surface. Geochemical and geophysical surveys show good anomalies but surface drilling may not locate the sulphides they reflect.

A relatively short (1,200') drift along the vein-fault which controls the replacements could outline vein deposits along the fault and would provide a location for extensive drilling in the limestones.

Experience has shown that underground work on replacement silver-lead-zinc deposits generally increases the tonnage of the deposits and the knowledge of their structural controls.

Detailed surface mapping of the claims and a re-study of drill cores is a prerequisite to any further work on the claims or in the area.

Yours truly,

D. C. Malcolm
PROFESSIONAL
D. C. MALCOLM, P. Eng.
Consulting Geologist
D. C. MALCOLM
BRITISH
COLUMBIA
ENGINEER



3100

3200

3300

3400

3500

3600

3700

3800

3900

CONTACT

Scale 1" = 100'

3600

3400

3200

3000

Quartzite

Quartzite

Scale 1"=100'

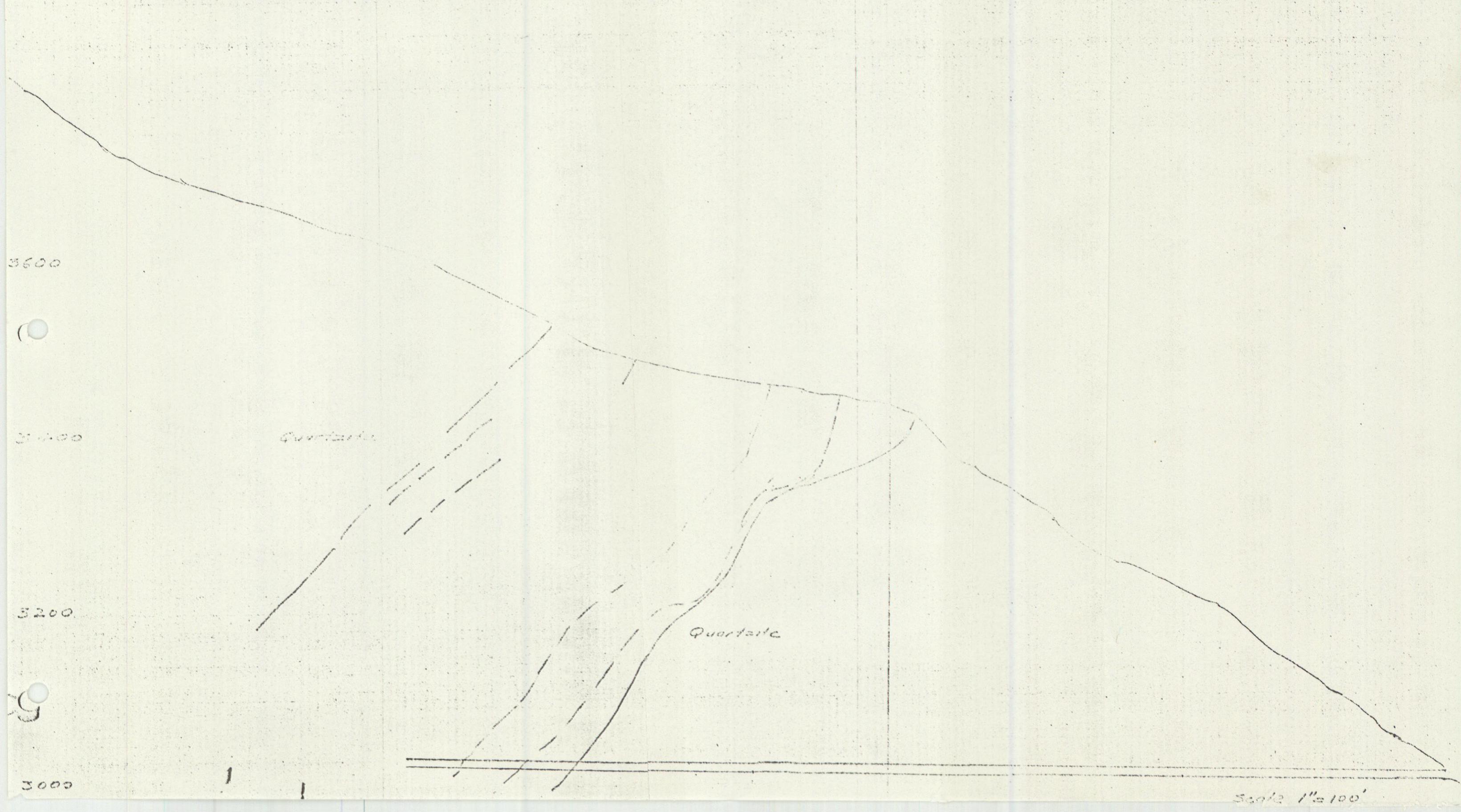

GENERAL EXPLORATION

1. Review of literature, study of air photographs, geochemical surveys and geophysical surveys of the area. This should include study of claim maps and a visit to Ottawa to discuss the area with geologists and Mines Branch officials.

2. Mapping and examination of known showings, using helicopters, in the area and strip flying of limestones by aircraft. This should show gossan zones and structures controlling the known deposits.

3. Geologists and prospectors should map and examine anomalous soil areas, gossans and favorable areas in the limestones camping on the areas and based in Clark Lake camp.

4. Options or staking properties of potential and bulldozer trenching.

ESTIMATED COSTS

One geologist	\$10,000.00
One prospector	6,000.00
Aircraft costs	20,000.00
Labor & helpers	5,000.00
Transportation & supplies	5,000.00
Contingencies	<u>4,000.00</u>
TOTAL	<u><u>\$50,000.00</u></u>

CLARK DEPOSIT

1. Geological mapping of the claims and re-logging of all drill holes should be done. A stratigraphic section and outcrops maps should be made of the properties.
2. Contacts should be projected underground possibly using Seismic surveys and structural maps showing faulting, folding and surface traces of the limestone beds should be done.
3. Visits should be made to the mines in the area to find operating costs and the availability of mining and milling equipment. Contractors should be interviewed.
4. A portal should be bulldozed with access roads to the winter road and to the Clark Camp. Surveys should be made with permanent stations between the surface and the portal.
5. The adit should be driven by contractors to the intersection on DD 13 along the vein fault. Drill slashes should be made at 200 foot intervals. Underground drilling should be done.

If this work is successful feasibility studies should be made for production.

Geology & Supervision	\$ 10,000.00
Transportation & Supplies	5,000.00
Camp Costs	5,000.00
Bulldozing	10,000.00
Surveying	2,000.00
Drilling 3,000 Ft. @ \$10/Ft.	30,000.00
Drifting 1,200 Ft. @ \$75/Ft.	90,000.00
Contingencies	<u>18,000.00</u>
TOTAL	<u>\$170,000.00</u>

BULLION MOUNTAIN MINING CO. LTD. (N.P.L.)

CLARK CLAIMS - YUKON TERRITORY

SUMMARY

The Clark claims cover a silver-lead-zinc replacement deposit in Lower Cambrian limestone in the Mayo District of the Yukon.

In 1971 diamond drilling over an area 200 by 300 feet showed good values and tonnages to a depth of 100 feet. Geological, geochemical and gravity surveys gave most encouraging results over a much larger area.

In 1972 extensive diamond drilling extended the original replacement to a depth of 500 feet over a length of 750 feet for widths up to 35 feet.

Three blocks are estimated to contain 477,000 tons averaging: 10.3 oz. silver, 7.95% lead and 4.45% zinc.

The drilling showed thicknesses of brecciated limestone of 600 feet and mapping has shown folded limestones in a mile by 3 mile area on the Scougale Creek to Rankin Creek area.

Detailed gravity and Induced Polarization surveys have indicated anomalous areas in both the limestone and quartzite. Geochemical work has indicated new anomalies.

GEOLOGY

Mapping, in 1972, has shown the Cambrian or older limestones are folded in an overturned anticline striking easterly and dipping southward with synclinal structures in areas underlain by quartzite.

These folds were involved in overthrusts, rock flowage, brecciation and numerous northeast and northwest striking faults. The limestone is extensive and trenching and mapping have shown it at Rankin Creek and for 6 miles west of this Creek in the McQueston-Scougale valley.

The brecciated limestone is mineralized over large areas by pyrrhotite with minor sphalerite. North 20 to 30° east striking steeply dipping faults contain galena bearing quartz veins in the quartzite and irregular galena replacements in limestone on major and minor fold axes. Some similar replacements occur in the quartzite. A similar deposit occurs on the Paul Group on Scougale Creek.

WORK DONE

The irregular replacements are difficult to follow both on the surface where they are oxidized and covered by quartzite boulders and at depth where long holes are necessary to locate them.

In 1972 diamond drilling extended the original deposit along strike and down dip. There are, at present, 3 mineable blocks as follows:

1. Surface Pit Block

127,650 tons, 6.95^{oz.} silver, 6.75% lead and 5.61% zinc.

2. Main Block

285,750 tons, 9.07 oz. silver, 6.88% lead and 3.59% zinc.

3. Top Block

63,750 tons: 22.9 oz. silver, 15.30% lead and 6.24% zinc.

These total 477,000 tons averaging: 10.28 oz. silver, 7.97% lead and 4.45% zinc.

The down dip extension is open and the extensions east and west have not been located despite extensive drilling.

A detailed gravity survey was made in 1972 and this showed marked anomalies. Some diamond drilling was done to test three of these but no new replacements were found.

An Induced Polarization survey was made and this showed anomalies both in the limestone and quartzite areas. No testing has been done on these but drilling is being considered at present.

In 1971 widespread geochemical anomalies were found a mile west of the central ore body. Three diamond drill holes were drilled but they showed only oxidized material containing pyrite and sphalerite. They have not been sampled.

Further geochemical sampling has been done for over 3 miles to the west and anomalous lead and zinc values were found.

Detailed work is necessary to further outline these results.

Geochemical sampling has been done on the Ram and Cen claims, 8½ miles west of the centre pit, south of McQueston Lake.

Geological mapping, on a reconnaissance basis, was done. It was found that quartzite boulders mask the surface geology and limestone outcrops are scarce. Limestone does outcrop 2½ miles east of McQuesten Lake and solution cavities occur in the valley floor 2 miles east of the Lake.

Bulldozer trenching has exposed limestone on the Priority and Quest claims and the Geological Survey Of Canada, Memoir 357 by L.H. Green has mapped limestone on the Paul Group and on Ranken Creek southeast of the Central Area. This report also describes the Paul Group deposits which occur in limestone along a north 27° east striking fault. A Department of Energy, Mines and Resources, Mines Branch sample assayed: 40.48 oz. silver per ton, 40.9% lead and 10.75% zinc. This report confirms our thoughts that other deposits, similar to the Bullion deposits, occur throughout the Clark Lake area.

These deposits will be concealed beneath overburden or quartzite in folded limestones on north to northeast striking faults or as widespread disseminated pyrrhotite-sphalerite-galena deposits in limestone.

PROPOSED WORK

Diamond drilling will be continued to test Induced Polarization, gravity and geochemical anomalies and to test geological structures found in the continuing geological study.

An underground program involving a 1,000 foot crosscut along a north 30° east mineralized fault, through quartzite, to reach the explored bottom of the main deposit is being considered.

Vancouver, B.C.
September 12, 1972

REPORT ON
INDUCED POLARIZATION SURVEY
KENO-MAYO DISTRICT, YUKON TERRITORY
ON BEHALF OF
SCURRY-RAINBOW OIL LIMITED

by

Michael J. Lewis, M.Sc.

and

Peter J. Fominoff, B.A.Sc.

CLAIMS:

Clark 1 - 86 (inclusive)

LOCATION:

18 miles north of Keno Hill
Mayo District, Yukon Territory
64°08' N 134°57' W

DATES:

August 3rd to 20th, 1972

CONTENTS

	<u>Page No.</u>
SUMMARY	
INTRODUCTION	1
GEOLOGY OF SURVEY AREA	1
METHOD AND INSTRUMENTATION	3
THE SURVEY GRID	4
PRESENTATION OF RESULTS	4
DISCUSSION OF RESULTS	5
CONCLUSIONS AND RECOMMENDATIONS	15

FIGURES AND PLATES

Figure 1 - Location Map	Scale 1 inch = 4 miles
Figure 2 - Three Electrode Array	
Plate 1 - Grid Plan	Scale 1 inch = 200 feet
Plates 2 and 3 - Chargeability and Resistivity Profiles	Scale 1 inch = 200 feet
Plates 4 and 5 - Chargeability and Resistivity Contours (respectively)	Scale 1 inch = 100 feet
Plate 6 - Apparent Metal Factor Contours	Scale 1 inch = 100 feet



SUMMARY

During August, 1972, an induced polarization survey was carried out in the Mayo Area, Yukon Territory by Seigel Associates Limited on behalf of Scurry-Rainbow Oil Limited.

Several induced polarization anomalies of possible interest for sulphide mineralization were outlined. Diamond drilling is recommended to sample these indications.

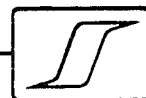

REPORT ON
INDUCED POLARIZATION SURVEY
KENO-MAYO DISTRICT, YUKON TERRITORY
ON BEHALF OF
SCURRY-RAINBOW OIL LIMITED

INTRODUCTION

During the period August 3rd to 20th, 1972, an induced polarization survey was carried out in the Keno-Mayo District of the Yukon by Seigel Associates Limited on behalf of Scurry-Rainbow Oil Limited. The survey crew was under the direction of Mr. Francis Bourqui.

The survey property is located south of Clark Lakes in the Davidson Range 18 miles north of Keno Hill in the Mayo District of the Yukon - see Figure 1. Access to the area is by a tractor road from McQuestion Lake which is connected by paved highway to Mayo and Whitehorse.

The elevation of the property ranges from about 2000 to 4500'. The topography is gentle and rounded. Tree cover is sparse.

The claims covered, in whole or in part, by the survey are designated "Clark" Numbers 1 - 86 inclusive.

GEOLOGY OF SURVEY AREA

The geology of the survey area is described in "Report on Bullion Mountain Mining Company Limited (N.P.L.) Clark Claims, Yukon Territory" by D. C. Malcolm, P.Eng., Consulting Geologist, dated November 15, 1971.

The Clark claims are underlain by quartzite, quartz mica schist, graphitic schist and limestone. They contain a silver-lead-zinc replacement body known as the Clark Deposit which appears, at surface, as a gossan zone in a Lower Cambrian limestone window in quartzites - see Plate 1. The deposit has been explored, by diamond drilling and trenching, over an area 200' by 300' and is up to 100' in thickness. Mineralization occurs in

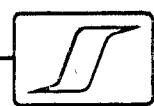

bands parallel to the quartzite/limestone contact. it strikes about east-west and dips about 15° S. The deposit is a potential source of silver, lead and zinc similar to other ore bodies found in the Keno-Mayo District.

Geochemical surveys carried out over the area by Bullion Mountain Mining Company Limited show extensive areas of base metal soil anomalies in favourable rocks. The geochemical work is described in D. C. Malcolm's report.

A gravity survey executed in the area in 1971 by Airborne Geophysical Surveys Limited of Calgary is described in "Clark Lakes Area, Yukon Territory Gravity Interpretation for Bullion Mountain Mining Company Limited" by R. B. Galeski, P.Geoph. dated November 1971. Four areas of moderate to high gravity response were outlined by the survey; the approximate locations of the anomaly axes are indicated on Plate 1.

Airborne magnetic surveys, carried out over the area by the Department of Mines and Technical Surveys, indicate that the limestone area (see Plate 1), including the lead-zinc replacement deposit, is located in an area of low magnetic relief.

The purpose of the present survey was to examine the electrical properties of the Clark claims and to assess the potential importance and significance of the observed gravity and geochemical anomalies. All of the geological, geophysical and geochemical information available to the writers has been taken into consideration and has been incorporated in the present report.

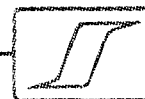

METHOD AND INSTRUMENTATION

A Scintrex Mark VII 2.5 kw time-domain induced polarization unit was employed. This unit has a current "on" time of 2.0 seconds and a current "off" (potential measuring time) of 2.0 seconds. The polarization transient voltages are integrated between the .45 to 1.1 second part of the "off" cycle and normalized to the "on" cycle voltage at the receiver. The resulting Chargeability in milliseconds is a measure of the induced polarization effect. The Resistivity, or average resistance in ohm-meters of the rocks in the measurement zone, is computed from the formula $R = C \times V_p \div I$ where V_p = on cycle voltage at the receiver, I = current output from the transmitter, C = a constant depending on the array geometry. For the present survey the three electrode array was utilized. This array is shown schematically below in Figure 2.

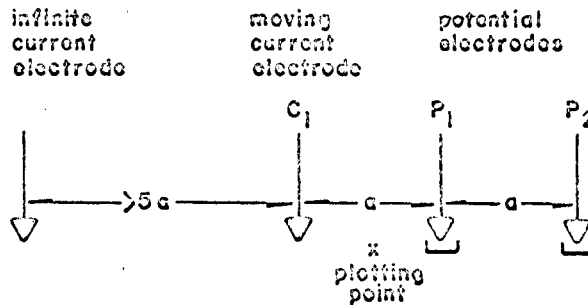

INTERLINE SPACING NOT TO SCALE.

Potential or "a" spacings of 100' and 200' were employed throughout for reconnaissance purposes. Readings were taken at intervals of 100'. Additional detailed coverage was undertaken over one line utilizing an "a" spacing of 400'. The plotting point for the three electrode array is taken as the midpoint between the C₁ and P₁ electrodes (see Figure 2). Topographic variations and geological inhomogenities may result in the

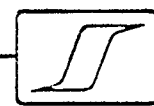

centre of the anomalous zone being shifted from its apparent location using this midpoint convention.

Induced polarization responses may arise from metallic or non-metallic agencies. The former include most sulphides (except sphalerite), arsenides, a few oxides such as magnetite and, unfortunately, graphite. Non-metallic sources include alteration minerals such as sericite, chlorite, serpentine and some clay minerals. There is no reliable criterion for differentiating between the over-voltage responses from metallic or non-metallic agencies or for distinguishing between the responses of one type of sulphide and another.

A more detailed description of the induced polarization method is contained in the attached copy of Dr. H. O. Seigel's paper entitled "Induced Polarization Method" dated 1970.

THE SURVEY GRID

The configuration and orientation of the survey grid are shown in plan form on Plate 1. Surveys were conducted over a total of 11 parallel lines striking about N 20° E designated L-3, L-2, L-1.5 E, L-0, L-2 W --- L-48 W and L-52 W. The interline separation was, generally, 200'.

A total of 5 line miles of geophysical coverage were attained.

PRESENTATION OF RESULTS

The survey grid, claim boundaries, general geology, gravity anomaly axes, etc., are shown on Plate 1 on the scale of 1 inch = 400 feet.

Plates 2 and 3 show the Chargeability and Resistivity data in profile form. The horizontal scale is 1 inch = 400 feet. Plate 2 covers Lines 3 E to 10 W inclusive; Plate 3 covers Lines 48 W and 52 W. The interline separations are not to scale. The chargeability profiles have a

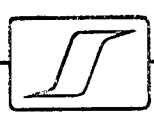

vertical scale of 1 inch = 10.0 milliseconds. The resistivities are plotted on a vertical logarithmic scale of 2 inches = 1 log cycle - the base level is 100 ohm-meters.

Plates 4 and 5 show the 200' Chargeability and Resistivity results in contour form. The horizontal scale is 1 inch = 100 feet. The contour intervals are 2.0 milliseconds for the chargeability and logarithmic for the resistivity.

Apparent Metal Factor values for the 200' data is shown on Plate 6. The horizontal scale is again 100 feet. The Metal Factor units are Chargeability/Resistivity X 1000.

DISCUSSION OF RESULTS

The contoured Chargeability, Resistivity and Metal Factors, presented on Plates 4, 5 and 6, constitute a summary of the geophysical observations and not their interpretation. Though certain qualitative conclusions can be readily drawn from these plans they must not be relied upon in detail because of the ambiguity of linear interpolation, the asymmetry of the three electrode array, etc. For a detailed look at the line-by-line results, the geophysical profiles (Plate 2) should be consulted.

The Resistivity Results

The grid area (Lines 3 E - 10 W inclusive) can be divided into at least four distinct regions on the basis of their resistivity characteristics. These are designated Regions A, B, C and D on Plate 5.

As indicated on Plate 5, Regions A and B are prominent resistivity depressions apparently reflecting limestones and graphitic schists. C and D are areas of extremely high relief (several thousands of ohm-meters) which

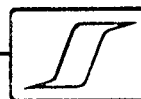

correlate with quartzite and quartz-mica schist.

Region A - is a very distinct U-shaped trough striking about east-west across Lines 3 E to 10 W inclusive. It is open grid east and grid west and is centred at about 2 + 50 S, Line 4 W. It has extremely sharp straight boundaries suggesting near vertical (limestone/quartzite) contacts. The floor of the trough slopes grid south.

Detailed coverage on Line 10 W suggest that Zone A is a wedge of highly conducting material extending from ground surface to a depth of at least 300' on its western side. The indicated intrinsic resistivity of this material is less than 10 ohm-meters.

Region B - is located about 1100' grid south of, and is similar in practically all details to, Region A. Its north and south boundaries are very sharp, again suggesting near vertical (limestone/quartzite) contacts. It is V-shaped in profile, narrow and open grid west. It centres at about 14 + 00 S on Line 3 W. The trough floor slopes about grid north indicating a northerly slope to the underlying formations.

Though apparently an area of quartzites, Region B represents a wedge of low-resistivity material (less than 50 ohm-meters) extending from near surface to a depth of more the 250'.

The resistivity low of less than 600 ohm-meters at L 0 + 00, 16 S may represent a (faulted-out) extension of Region B as suggested on Plate 5.

Region C - is an area of very high resistivity constituting the background relief north of Region A (see Plate 5). The resistivities uniformly range from about 3000 to 10,000 ohm-meters and no doubt reflect clean highly-resistive non-mineralized quartzite.

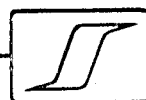

Region D - lies south of Region A and surrounds Region B. It constitutes the background relief. Resistivities range from about 1000 to 10,000 ohm-meters again reflecting (relatively) pure non-conducting quartzites and sericite schists. Resistivity profiles within Region D are slightly more disturbed however than those encountered in Region C indicating some variations in conductivity within the quartzite.

In general, the resistivity data show a quartzite/limestone resistivity contrast of more than 100:1. Regions A and B both coincide with prominent gravity highs (see Plate 1). A has a coincident 1.5 milligal indication; B a coincident .4 milligal response. As suggested on Plate 5, the iso-milligal configurations are similar in outline and extent and in peak location to the observed iso-resistivity lines. The coincidence of such (relatively) large gravity anomalies with such extremely low resistivities suggest that the source of the resistivity depressions may be, at least in part, metallic (sulphides etc.) rather than graphitic.

Similar extreme resistivity variations appear on Lines 48 W and 52 W (see Plate 3). On Line 52 E, for example, prominent resistivity depressions were observed as follows:

- (1) Extending from station 3 + 50 S to 10 N (1300' wide)
- (2) Extending from stations 14 N to 18 N (about 400' wide)

In both instances the resistivity profiles are depressed by a factor of at least 20, relative to their surrounds.

It may be assumed, on the basis of the foregoing discussion of the main grid area, that the major Resistivity "highs" and "lows" observed on Lines 48 W and 52 W reflect "quartzites" and "limestones" respectively attesting to the widespread lateral distribution of these major rock types.

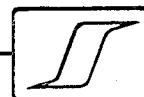

The Chargeability and Metal Factor Data

Average background chargeability values recorded within the survey block range from about 5.0 to 10.0 milliseconds (for both the 100' and 200' "a" spacings). These values, though slightly above the normal non-metallic background range for most rock types, may be considered, in the present area, to represent non-mineralized formations. Since a subsurface distribution of about 1% by volume of disseminated metallicly conducting mineralization may be expected, on average, to contribute about 10.0 milliseconds to the background level in the present area, values in excess of about 15.0 milliseconds may be considered sufficiently anomalous to warrant attention.

Four prominent bands of relatively high chargeability amplitude were observed in the area. These are designated A, B, C and D on Plate 4. All of these Zones contain values in excess of 30.0 milliseconds.

Since the survey area shows extreme resistivity variations (several orders of magnitude exist between individual resistivity "highs" and "lows" along each survey line) and since the induced polarization method suffers from limitations imposed by "saturation effects" associated with such extreme contrasts "Apparent Metal Factors" have been calculated and contoured for the 200' data. The "Metal Factor", which is equivalent to the ratio of induced polarization response/resistivity, tends to compensate for the "saturation effects" by re-emphasizing the polarization effects in highly conductive rocks.

The Metal Factor contour plan (Plate 6) has, like its Resistivity counterpart, been divided into four principal sections (Regions A, B, C and D). Regions A and B reflect highly conducting formations (limestones), C and D highly resistive rocks (quartzites). A and B correlate with prominent

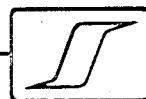

elevated gravity values, C and D with (relatively) low background gravity relief. On the basis of the Resistivity and Metal Factor data the "limestones" are uniformly conductive throughout; the "quartzites" uniformly non-conductive.

The anomalous chargeability Zones have the following characteristics:

Anomaly A

Anomaly A is sharply portrayed on the 100' profiles (Plate 2). It appears as a narrow high-amplitude anomaly extending about east-west across the survey grid. It has 100' peak amplitudes at the following locations:

- 27.0 millise. at 2 + 50 S Line 3 E - Coincident Resistivity 'high'
- 33.3 millise. at 1 + 50 S Line 2 E - Coincident Resistivity 'low'
- 77.0 millise. at 1 + 50 S Line 00 - On Flank of Resistivity 'low'
- 57.9 millise. at 1 + 50 S Line 2 W - Sharp coincident Resistivity 'high'
- 55.7 millise. at 2 + 50 S Line 4 W - On S flank of sharp Resistivity 'high'
- 75.2 millise. at 1 + 50 S Line 6 W - Sharp Coincident Resistivity 'high'
- 67.2 millise. at 2 + 50 S Line 8 W - Coincident Resistivity 'low'
- 47.0 millise. at 3 + 50 S Line 10 W - Coincident Resistivity 'low'

In profile Anomaly A is assymmetric with its steep slope located grid north. It is centred, more or less, over the mid-part of a resistivity trough (region A). It strikes about east-west, it is open grid west and is located about 150' - 250' south of the Base Line. On the basis of the rather limited detail coverage undertaken on Line 10 W it appears to reflect a very narrow band of highly conducting material dipping grid south and coming to within a few tens of feet of the ground surface in the vicinity of the peak locations listed above. It represents an excess of about 60.0

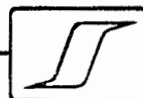

milliseconds above the average (quartzite) background and could be caused by a narrow band of 6% - 8% by volume of disseminated metallicly conducting mineralization.

On Plate 6 Anomaly A appears as a very high Metal Factor response which, in places, is coincident with, and, in others, slightly north of, a gravity high. The Line 00 and Line 6 W profiles (Plate 2) show the relation between the chargeability and gravity information. It is evident that there is a strong near-coincidence between the chargeability and gravity anomaly peaks. In addition, A coincides with anomalous zinc levels in the soils.

East of Line 0, Anomaly A has been sampled by diamond drilling. Holes W-6 and W-8, for example, appear to have intersected the Zone - good lead-zinc mineralization was encountered in both holes at depths in harmony with those indicated by the induced polarization results. Graphitic material, however, seems to be a common constituent of the subsurface formations - thus there is some ambiguity regarding the relationship between the induced polarization response and the metallic sulphides. Anomaly A has not been drilled west of Line 0.

Anomaly B

Anomaly B is very prominently displayed in profile form (Plate 2) near the southern ends of Lines 00 and 10 W inclusive. From east to west it increases in amplitude and clarity. It is very clearly displayed by both "a" spacings in comparison with its counterpart to the north (Anomaly A) which is poorly defined by the 200' data. On Plate 4, Anomaly B appears as a 200' wide east-west trending zone of high chargeability opening grid west. It coincides on almost all lines with resistivity Region B. Peak 100' responses are located as follows:

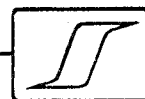

32.1 millisecc. at 14 + 50 S, L 10 W - Coincident Resistivity 'low'
 35.8 millisecc. at 14 + 50 S, L 8 W - On S flank of Resistivity 'low'
 36.5 millisecc. at 14 + 50 S, L 6 W - Coincident Resistivity 'low'
 24.5 millisecc. at 13 + 50 S, L 4 W - Coincident Resistivity 'low'
 18.5 millisecc. at 13 + 50 S, L 2 W - Coincident Resistivity 'low'
 15.0 millisecc. at 14 + 50 S, L 00 - Coincident 100' Resistivity 'high'

Anomaly B represents an excess of more than 30.0 milliseconds above the average background (7.0 to 10.0 milliseconds) and could be caused by 3% - 5% by volume of disseminated metallicly conducting mineralization in the bedrock. Such mineralization likely dips steeply grid south. It is closely associated with a .4 milligal gravity high as indicated on Plates 1 and 2. It also has coincident weakly anomalous zinc indications. To date, it has not been sampled by diamond drilling.

Anomaly C

Anomaly C is a narrow high amplitude indication striking about N 75° W across Lines 3 E - 10 W inclusive. Proceeding from Line 3 E westwards through Line 10 W, it diverges slightly grid west.

Anomaly C is clearly defined by both the 100' and 200' chargeability profiles. It gave maximum 100' responses at the following locations:

24.1 millisecc. at 50 S, L 3 E - Limestone/Quartzite Contact Zone
 20.0 millisecc. at 50 N, L 2 E - Limestone/Quartzite Contact Zone
 42.3 millisecc. at 50 N, L 00 - Limestone/Quartzite Contact Zone
 44.7 millisecc. at 50 N, L 2 W - Limestone/Quartzite Contact Zone
 33.0 millisecc. at 2 + 50 N, L 4 W - Limestone/Quartzite Contact Zone
 33.5 millisecc. at 2 + 50 N, L 6 W - Limestone/Quartzite Contact Zone

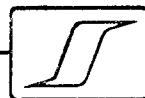

34.0 millisecon. at 2 + 50 N, L 8 W - Limestone/Quartzite Contact Zone
 52.1 millisecon. at 1 + 50 N, L 10 W - Limestone/Quartzite Contact Zone

Zone C has an intrinsic chargeability of more than 50.0 milliseconds over a background of 5.0 - 10.0 milliseconds. It could be caused by a narrow zone of 5 to 7% by volume of disseminated metallicly conducting material located on the quartzite/limestone contact and coming to within a few tens of feet of the ground surface.

As indicated on Plates 1 and 2, C is closely associated with a prominent gravity 'high'. It also appears to correlate with lead and zinc geochemical anomalies in the soils. Zone C has not been examined by diamond drilling.

Anomaly D

Anomaly D is a broad band of anomalous chargeability trending about N 80° E across Lines 3 E - 10 W inclusive. It is open grid east and grid west and stretches across the northern half of resistivity Region D. It is 500' wide and is clearly discernable on both the 100' and 200' profiles against an average background of less than 10.0 milliseconds. It gave peak 100' amplitudes at the following locations:

40.0 millisecon. at 7 + 50 S, L 10 W - Quartzite/Limestone Contact
 30.6 millisecon. at 9 + 50 S, L 10 W - Coincident Resistivity Low
 32.8 millisecon. at 6 + 50 S, L 8 W - Quartzite/Limestone Contact
 30.0 millisecon. at 9 + 50 S, L 8 W - Coincident Resistivity Low
 31.0 millisecon. at 7 + 50 S, L 6 W - Quartzite/Limestone Contact
 27.0 millisecon. at 8 + 50 S, L 4 W - Coincident Resistivity Low
 32.2 millisecon. at 6 + 50 S, L 2 W - Coincident Resistivity Low
 32.0 millisecon. at 8 + 50 S, L 2 W - Coincident Resistivity Low



31.8 millisecon. at 8 + 50 S, L 00 - Coincident Resistivity Low

30.0 millisecon. at 8 _ 50 S, L 2 E - Coincident Resistivity Low

30.5 millisecon. at 7 + 50 S, L 3 E - Coincident Resistivity Low

Anomaly D reflects at least two parallel conducting bands, one in the quartzite, the other on the quartzite/limestone contact. The Metal Factor contour plan shows little disturbance coincident with D - a fact not unexpected in view of its (relatively) high coincident resistivities.

On Lines 0, 1 E and 10 W two apparently localized near-surface high-gradient centres, designated sub-zones D₁ and D₂ on Plate 4, were observed. Both zones appear also as distinct anomalies on Plate 6. Both are situated on the quartzite/limestone contact and probably represent local concentrations of conducting material.

Anomaly D could be caused by 3% - 5% by volume of disseminated metallicly conducting mineralization distributed in bands throughout the quartzite and coming to within about 30 feet of the ground surface. The intrinsic chargeability of the mineralization is about 30.0 milliseconds.

Anomaly D lies on the south side of a major gravity high - see the 6 W and 00 profiles on Plate 2. There is some suggestion on the 00 profile of a weak gravity high coincident with D (note the flattening and break in slope on the profile). D is also closely associated with anomalous lead and zinc values in the soils.

Though at least two holes have been drilled within the confines of Zone D (Holes W-26 and W-27) both lie in a 100' chargeability 'low' and did not intersect polarizing material. Both holes gave 300' + of barren quartzite.

Sub-zone D₂ has been adequately drilled by holes W-16, W-21, W-22 and W-25A. Interesting Lead-Zinc sections were intersected in all these holes

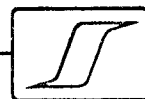

at depths and locations compatible with those indicated by the induced polarization data. Again the presence of graphitic material in these holes lends ambiguity to the cause-affect relationship.

Anomalous chargeability values were observed on Lines 48 W and 52 W - see Plate 3. Three distinct zones are discernible - these are marked A_1 , B_1 and C_1 on the profile.

Zone A_1 extends from 2 + 50 S to 10 + 50 N (Line 52 W). It consists of at least five sub-zones peaking as follows:

- 55.0 millisecc. at 0 + 50 S - Coincident Resistivity 'low'
- 58.0 millisecc. at 1 + 50 N - Coincident Resistivity 'high'
- 67.0 millisecc. at 3 + 50 N - Coincident Resistivity 'low'
- 54.0 millisecc. at 6 + 00 N - Coincident Resistivity 'low'
- 52.0 millisecc. at 9 + 50 N - On N Flank of 'low'

The background chargeabilities range from about 10.0 - 15.0 milliseconds.

Zone A_1 coincides with an area of extremely low resistivity and is similar in most respects (including lateral extent) with Anomaly B in the main area. A distribution of 5%-7% by volume of disseminated metallicly conducting mineralization would account for the high chargeabilities. Such mineralization is likely distributed in bands throughout the bedrock.

Zone B_1 is narrow (relative to A_1) extending from about 14 N to 16 N on L 52 W. It has high peak chargeability amplitudes of:

- 57.0 millisecc. on 14 + 30 N - A flank of major Resistivity 'high'
- 57.0 millisecc. on 16 + 50 N - A slope of major Resistivity 'low'

B_1 coincides with a prominent Resistivity depression again indicating a highly conducting locale (graphitic limestones, etc.). It is also associated

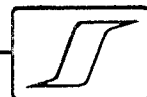

with a prominent zinc soil anomaly.

Zone C₁, unlike its associates above, is a high chargeability zone lying within a highly resistive area (quartzites). Peak 100' responses may be viewed as follows:

29.0 millise. at 6 + 50 S, L 52 W - Coincident Resistivity 'low'

41.5 millise. at 9 + 50 S, L 52 W - Coincident Resistivity 'low'

46.5 millise. at 11 + 50 S, L 52 W - Coincident Resistivity 'high'

The coincident resistivities decrease markedly with increasing "a" spacing suggesting an increase in conductivity with depth (possibly) indicating a shallow quartzite cover.

CONCLUSIONS AND RECOMMENDATIONS

1. The survey area (Lines 3 E - 10 W inclusive) is divisible into two "rock types" on the basis of their electrical properties. These are designated A-B and C-D on Plates 5 and 6.

Regions A and B are highly conducting "Limestones" with intrinsic resistivities of less than 10 ohm-meters and 50 ohm-meters respectively. Both coincide with significant gravity indications and with anomalous Lead-Zinc values in the soils. Region A is known to contain limestones and graphitic schists.

Regions C and D are areas of highly resistive "Quartzites" with an apparent resistivity range of 1,000 - 10,000 ohm-meters. The areas are known to contain quartzite and quartz mica schist.

2. The indicated geophysical boundaries and trends coincide with recognizable geological contacts and strikes. The contacts, in all instances,

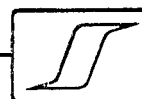

appear sharp and definitive.

3. The chargeability results have been partitioned into at least four anomalous bands - A, B, C and D on Plate 4. These bands correlate, more or less, with Regions A, B, C and D discussed above.

Anomaly A is a narrow high-amplitude zone striking about east-west through the "Limestones". It could be caused by 6% - 8% by volume of disseminated metallicly conducting mineralization (sulphides or graphite) localized in a narrow band dipping grid south and coming to within a few tens of feet of the ground surface. It is closely associated with a 1.0 milligal gravity 'high' and anomalous zinc levels in the soils.

Anomaly A has been sampled by diamond drilling east of Line 0 (Holes W-6 and W-8). Lead-zinc and graphitic mineralization was encountered at depths consistent with those indicated by the inducted polarization data.

Anomaly B could be caused by 3% - 5% by volume of polarizing material (sulphides or graphite) dipping about grid south and striking about east-west through the "Limestones". It occurs in combination with a .4 milligal gravity anomaly and with weak zinc indications. It has not been sampled by diamond drilling.

Anomaly C is a narrow zone of high response striking about N 75° W along a Limestone/Quartzite contact. It could reflect 5% - 7% by volume of disseminated conducting mineralization (sulphides or graphite) coming to within a few tens of feet of

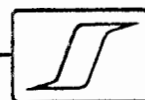

the ground surface. It appears to correlate well with anomalous gravity and geochemical indications. It has not been examined by diamond drilling.

Anomaly D consists of two zones of high chargeability, one lying on the Quartzite/Limestone contact, the other within the Quartzites. This zone could reflect 3% - 5% by volume of disseminated metallicly conducting material (graphite or sulphides) coming to within about 30 feet of the ground surface. Anomaly D has some anomalous geochemical signature and a suggestion of weak anomalous gravity responses.

D has been adequately drilled in one locale (Holes W-16, W-21, W-22 and W-25A cut Lead-zinc and graphite bearing sections below sub-zone D₂), and inadequately drilled at another (Holes W-26 and W-27 were barren).

4. Anomalous chargeability and resistivity conditions, similar in all respects to those listed above were observed on Lines 48 W to 52 W.

5. In view of the apparent coincidence between the Chargeability, Resistivity, Gravity and geochemical anomalies, the presence of interesting sulphide mineralization both in showings and in drill sections, and the apparent spatial and depth relationship between individual anomalies and sulphides, the present area warrants additional exploratory attention.

However, some factors suggest a cautious approach. These include the presence of graphite both in showings and in drill holes, and the extremely low Resistivities and high Metal Factors which, in other areas, are generally indicative of extensive pyritic or graphitic mineralization.

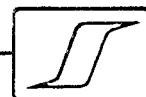

6. The following diamond drill holes are tentatively recommended to fully sample the observed anomalies.

Anomaly A

- DDH #1 - Collar at 2 + 50 S, L 6 W - drill grid north at 45° for a distance of 250 feet.
- DDH #2 - Collar at 3 + 50 W, L 4 W - drill grid north at 45° for a distance of 250 feet.
- DDH #3 - Collar at 3 S, L 2 W - drill grid north at 45° for a distance of 250 feet.
- DDH #4 - Collar at 2 + 50 S, L 00 - drill grid north at 45° for a distance of 200 feet.

Anomaly B

- DDH #5 - Collar at 15 + 25 S, L 8 W - drill grid north at 45° for a distance of 300 feet.
- DDH #6 - Collar at 15 + 25 S, L 6 W - drill grid north at 45° for a distance of 300 feet.
- DDH #7 - Collar at 14 + 25 S, L 4 W - drill grid north at 45° for a distance of 200 feet.
- DDH #8 - Collar at 12 + 25 S, L 00 - drill grid south at 45° for a distance of 300 feet.

Anomaly C

- DDH #9 - Collar at 50'N, L 10 W - drill grid north at 45° for a distance of 300 feet.
- DDH #10 - Collar at 2 + 00 N, L 8 W - drill grid north at 45° for a distance of 200 feet.
- DDH #11 - Collar at 1 + 50 N, L 6 W - drill grid north at 45° for a distance of 300 feet.
- DDH #12 - Collar at 1 + 25 N, L 4 W - drill grid north at 45° for a distance of 250 feet.
- DDH #13 - Collar at Base Line L 2 W - drill grid north at 45° for a distance of 300 feet.



DDH # 14 - Collar at 50 S, L 00 - drill grid north at 45°
for a distance of 250 feet.

Anomaly D

DDH #15 - Collar at 9 + 50 S, L 00 - drill grid north at 45°
for a distance of 250 feet.

DDH #16 - Collar at 5 + 50 S, L 00 - drill grid north at 45°
for a distance of 250 feet.

DDH #17 - Collar at 10 + 50 S, L 6 W - drill grid north at 45°
for a distance of 250 feet.

DDH #18 - Collar at 8 S, L 6 W - drill grid north at 45° for a
distance of 250 feet.

DDH #19 - Collar at 6 S, L 6 W - drill grid south at 45° for a
distance of 300 feet.

DDH #20 - Collar at 10 + 50 S, L 8 W - drill grid north at 45°
for a distance of 200 feet.

DDH #21 - Collar at 6 S, L 8 W - drill grid south at 45° for a
distance of 250 feet.

Line 52 W

DDH #22 - Collar at 1 + 50 S, L 52 W - drill grid north at 45°
for a distance of 250 feet.

DDH #23 - Collar at 1 N - drill grid north at 45° for a distance
of 300 feet.

DDH #24 - Collar at 10 + 50 N - drill grid south at 45° for a
distance of 300 feet.

DDH #25 - Collar at 13 + 50 N - drill grid north at 45° for a
distance of 250 feet.

The above drill locations, dip, lengths, etc., are provisional and
may of course be changed at the discretion of Scurry-Rainbow Oil Limited.



7. Initially, one hole should be drilled in each of the anomalous Zones in order to identify the probable source of the high chargeability response. Drill hole Nos. 2, 6, 9, and 17 are tentatively suggested as suitable primary locations.

Further exploratory work (drilling etc.) would be predicated upon the results of this initial programme.

Respectfully submitted,

SEIGEL ASSOCIATES LIMITED

Michael J. Lewis, M.Sc.
Geophysicist

Peter J. Fominoff, B.A.Sc.
Geophysicist

Vancouver, B. C.
August 25, 1972

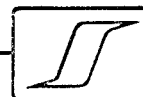
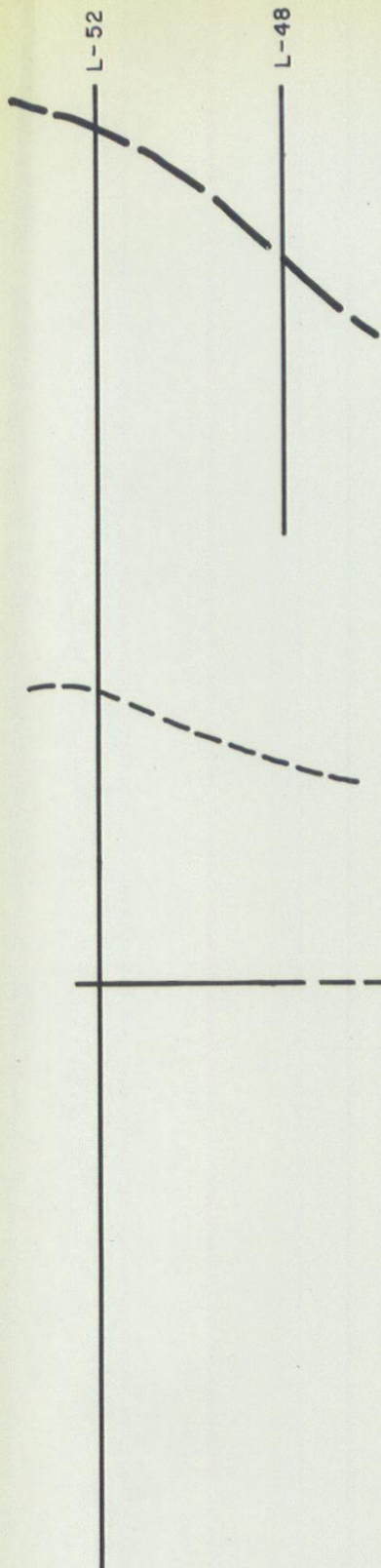

PLATE I
GRID PLAN



SCURRY RAINBOW OIL LTD.
KENO HILL AREA, Y.T.

SCALE 1" = 400'



BASELINE

LEGEND

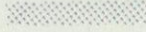
-  DEFINITE CONTACT
-  ASSUMED CONTACT
-  GEOCHEM. HIGHS
-  GRAVITY HIGHS

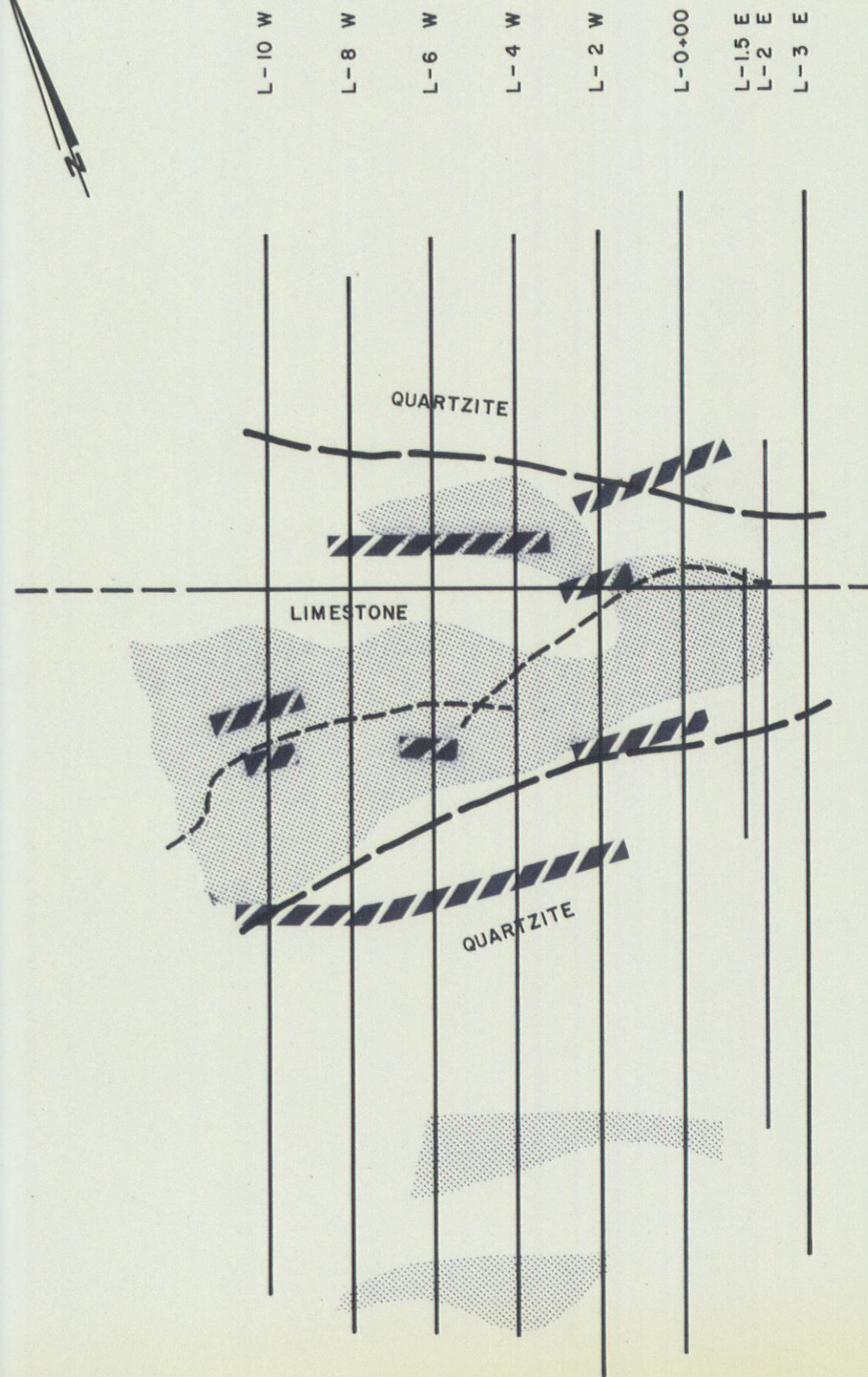

L-10 W

L-8 W

L-6 W

L-4 W

L-2 W

L-0+00

L-1.5 E

L-2 E

L-3 E

QUARTZITE

LIMESTONE

QUARTZITE

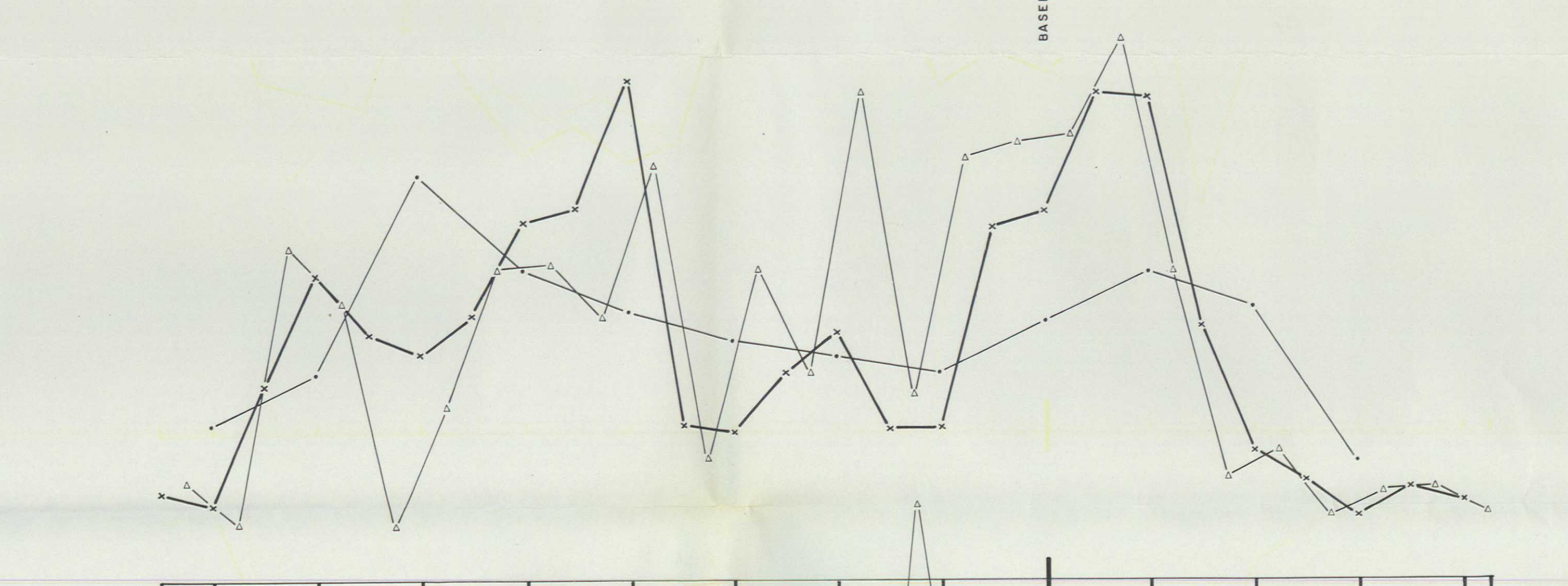
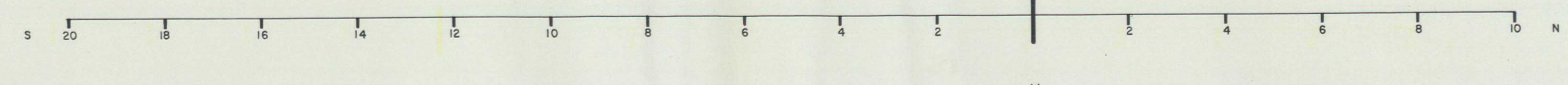
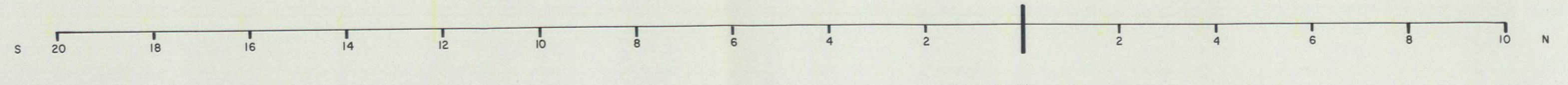

L-10 W

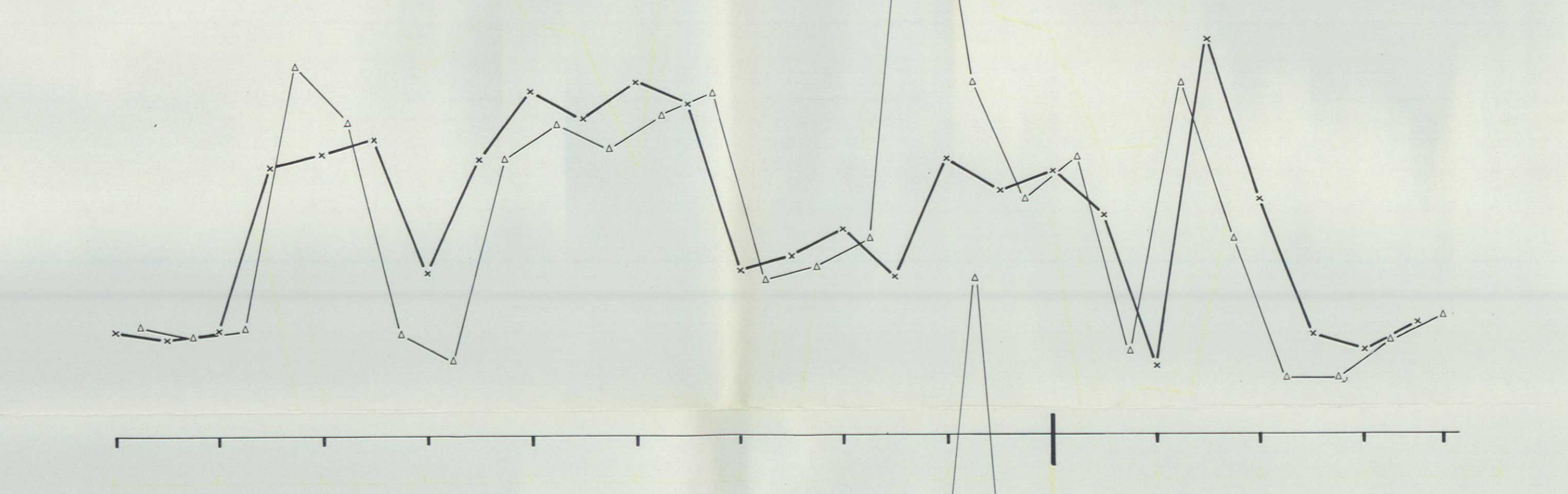
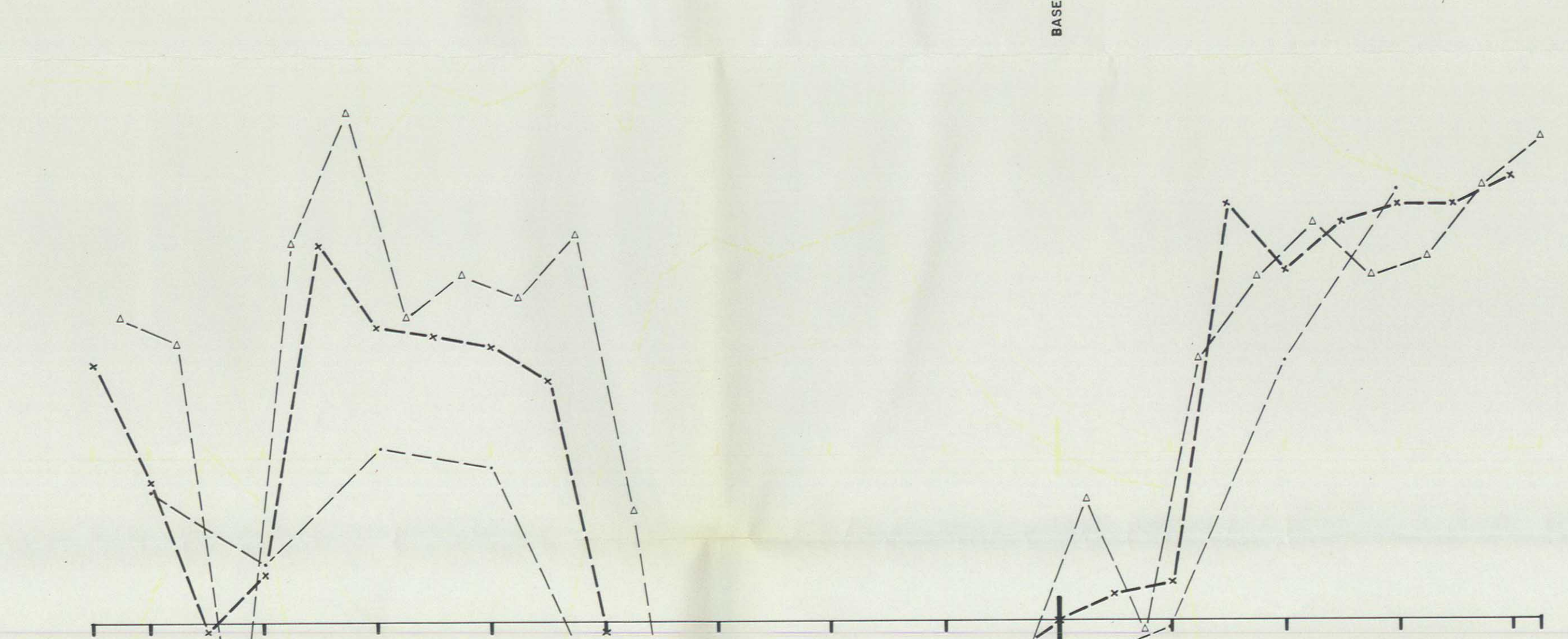

L-8 W

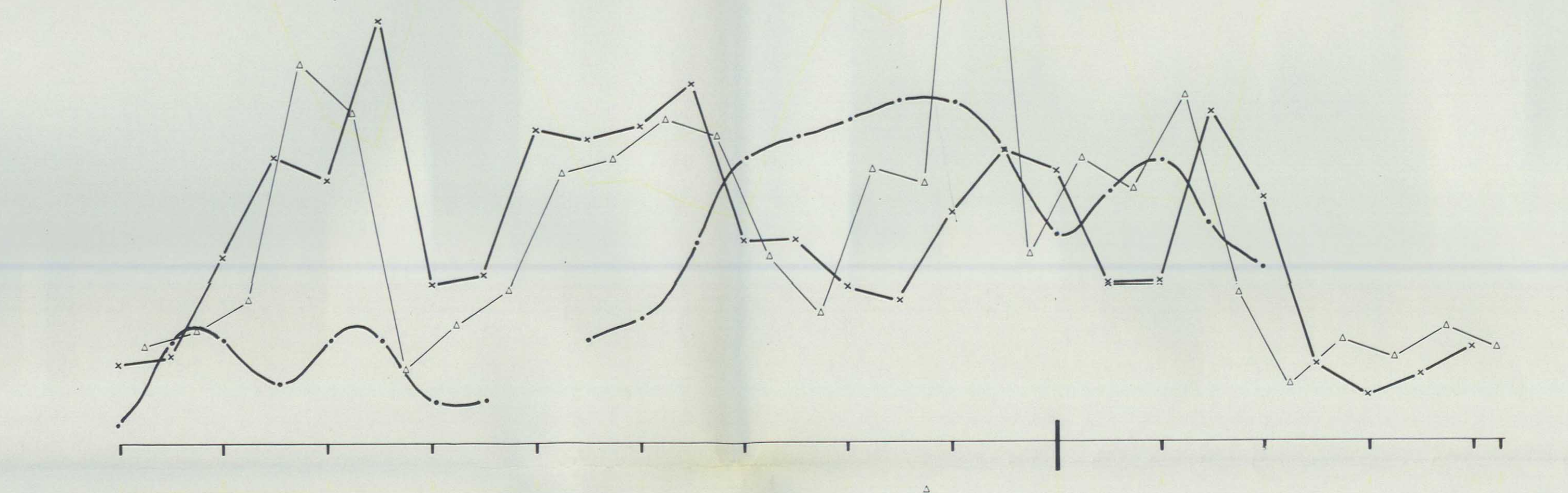
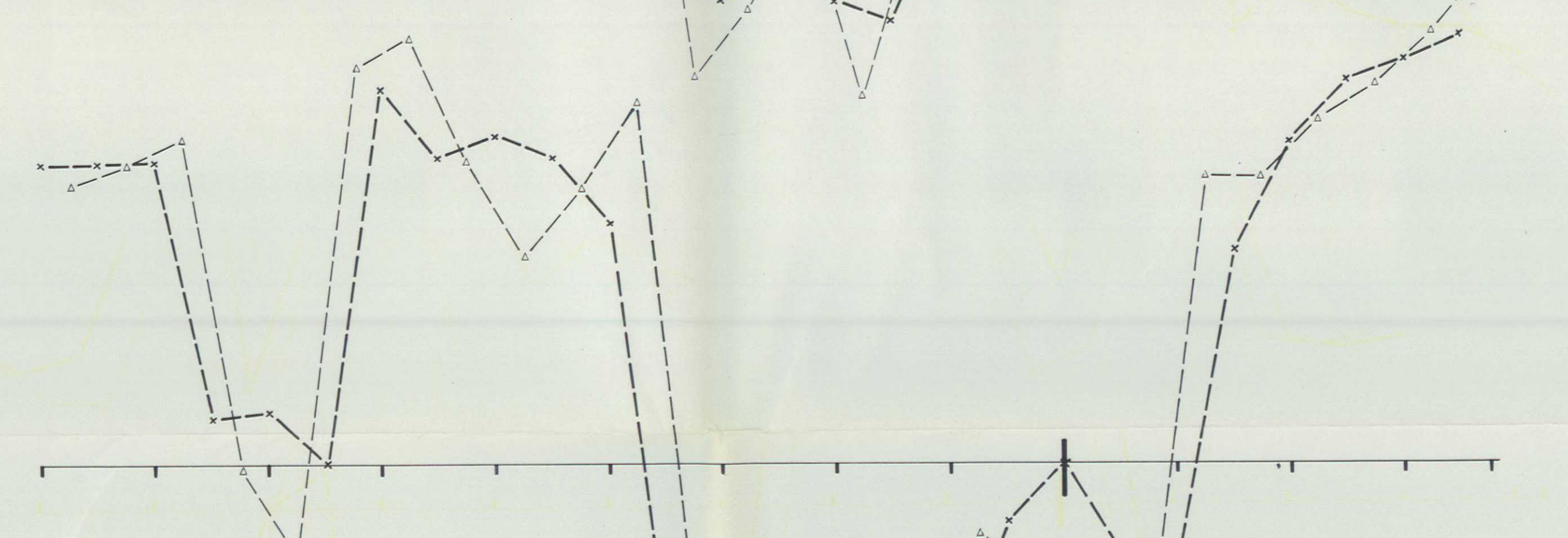

L-6 W

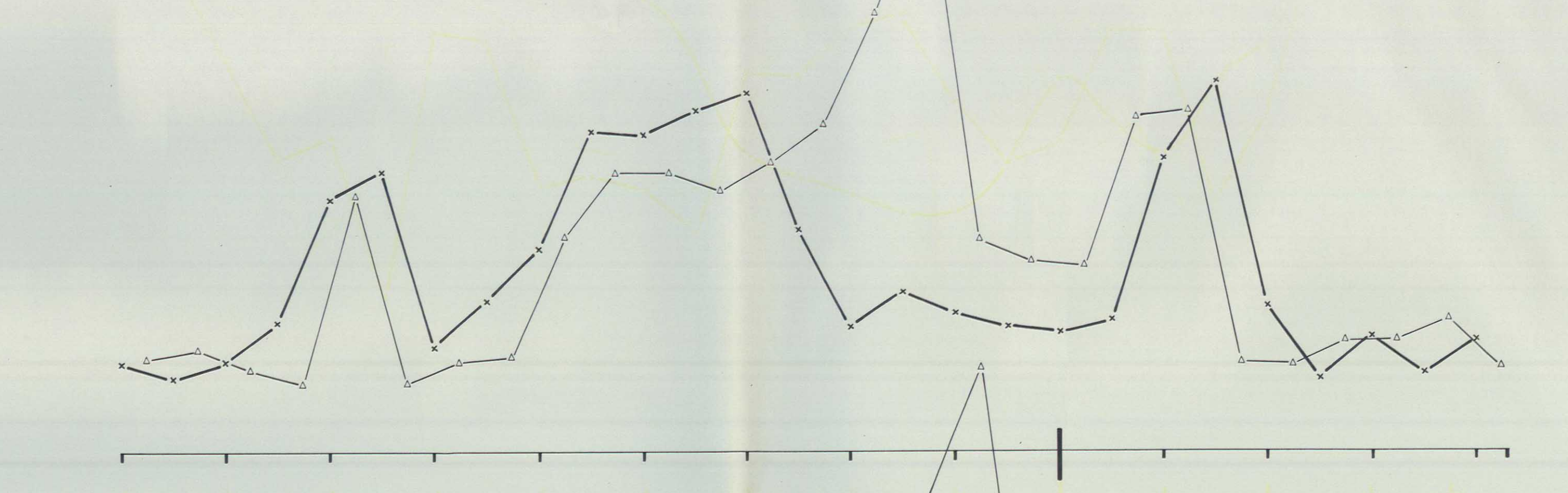
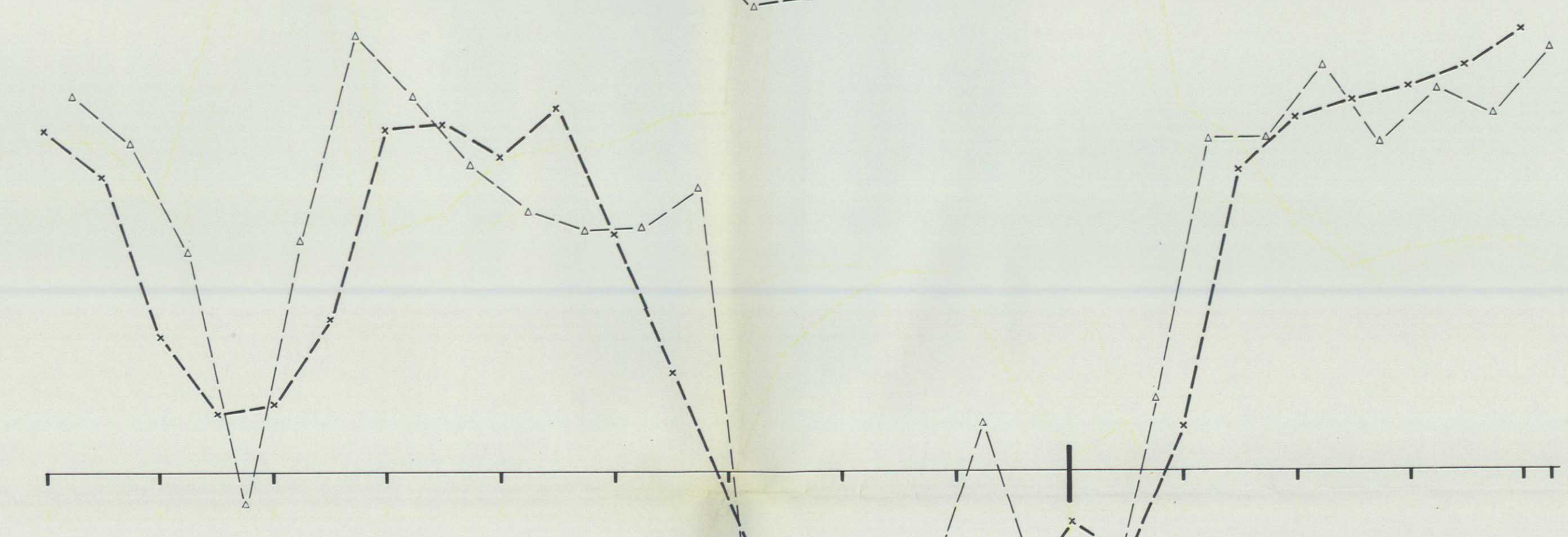

L-4 W

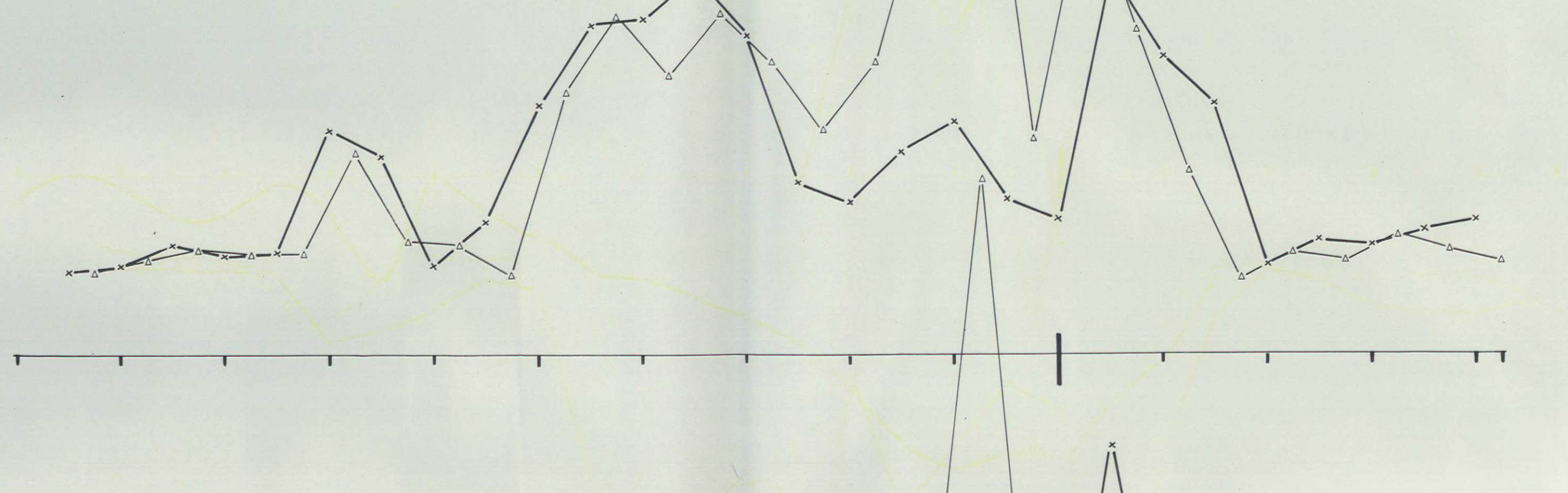
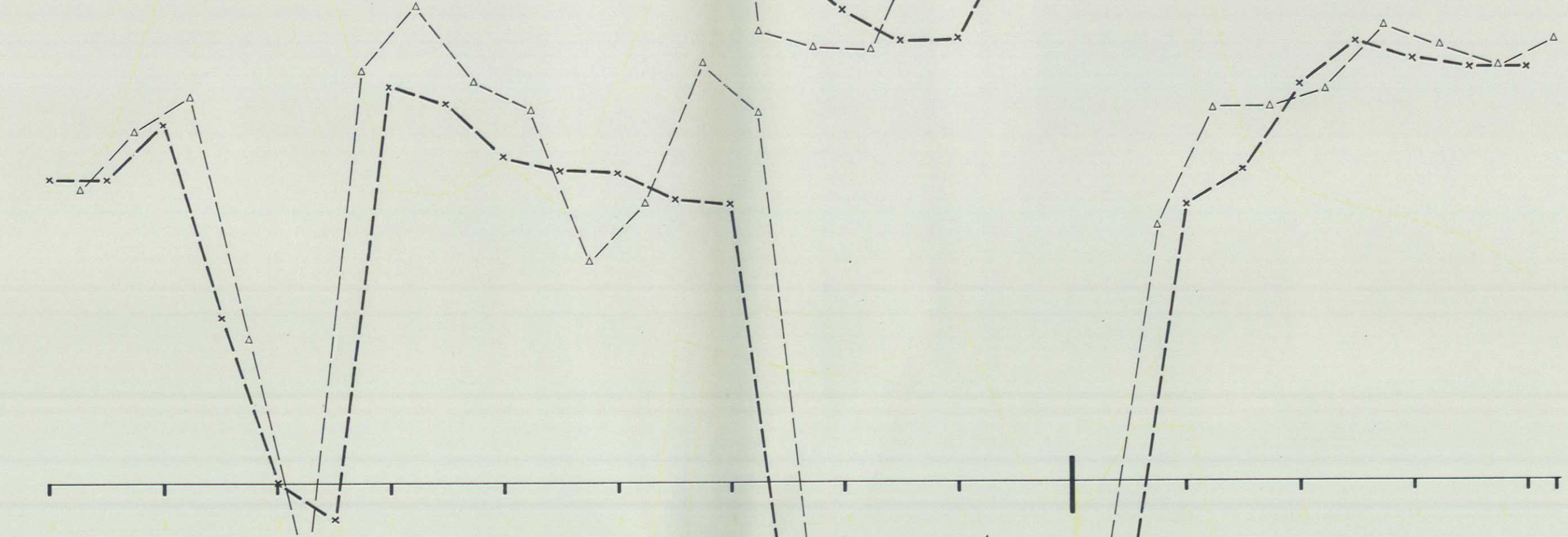

L-2 W

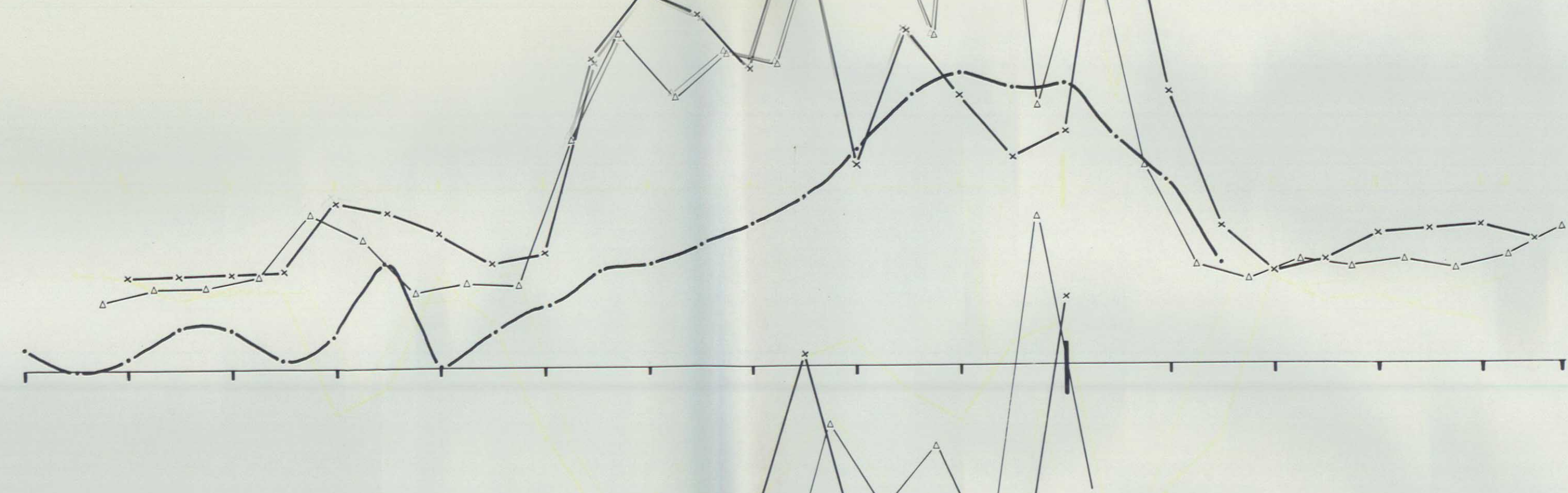
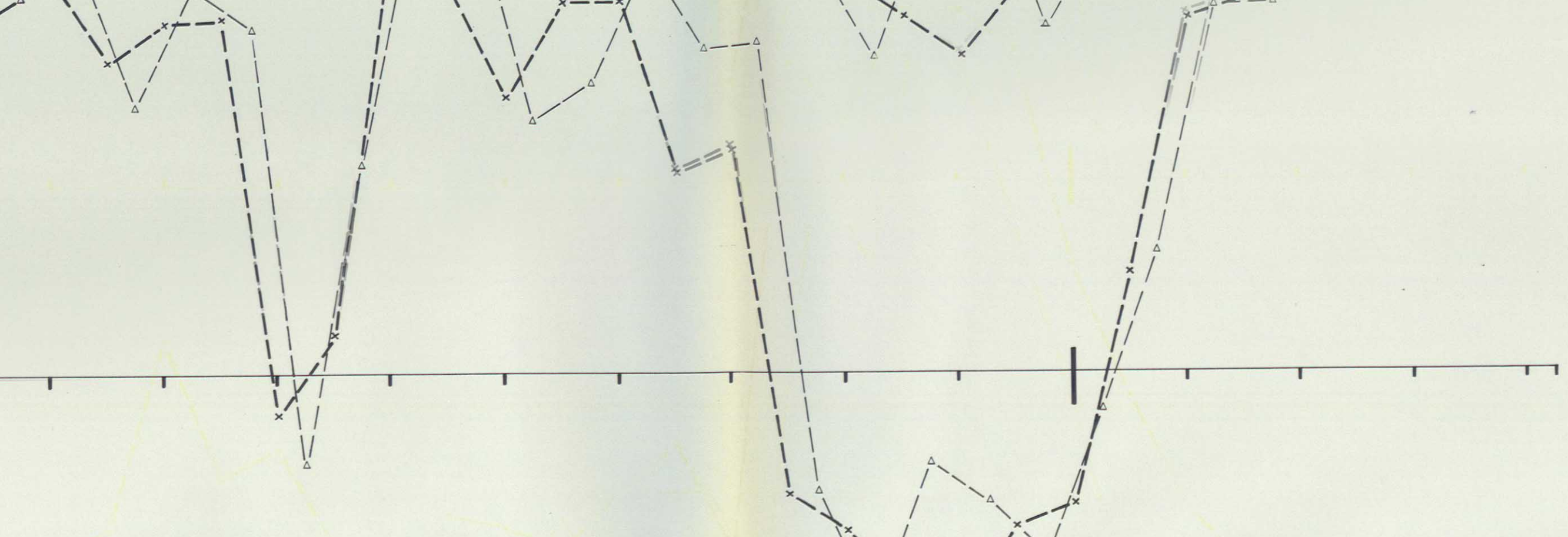

L-0+00

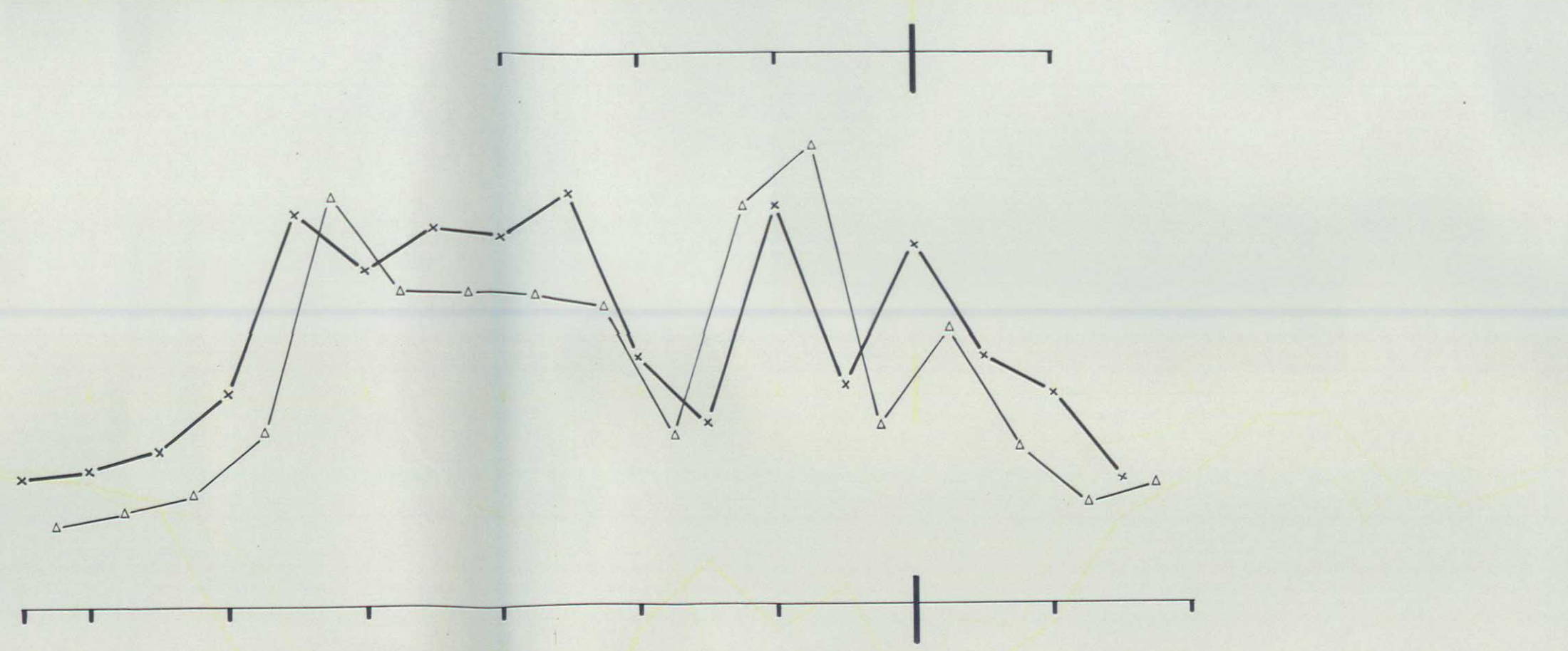
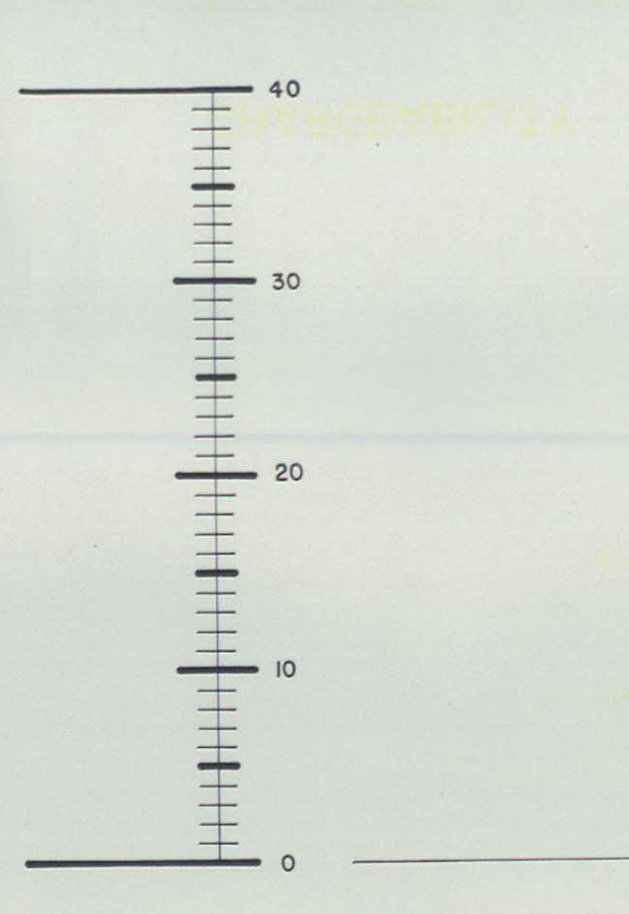
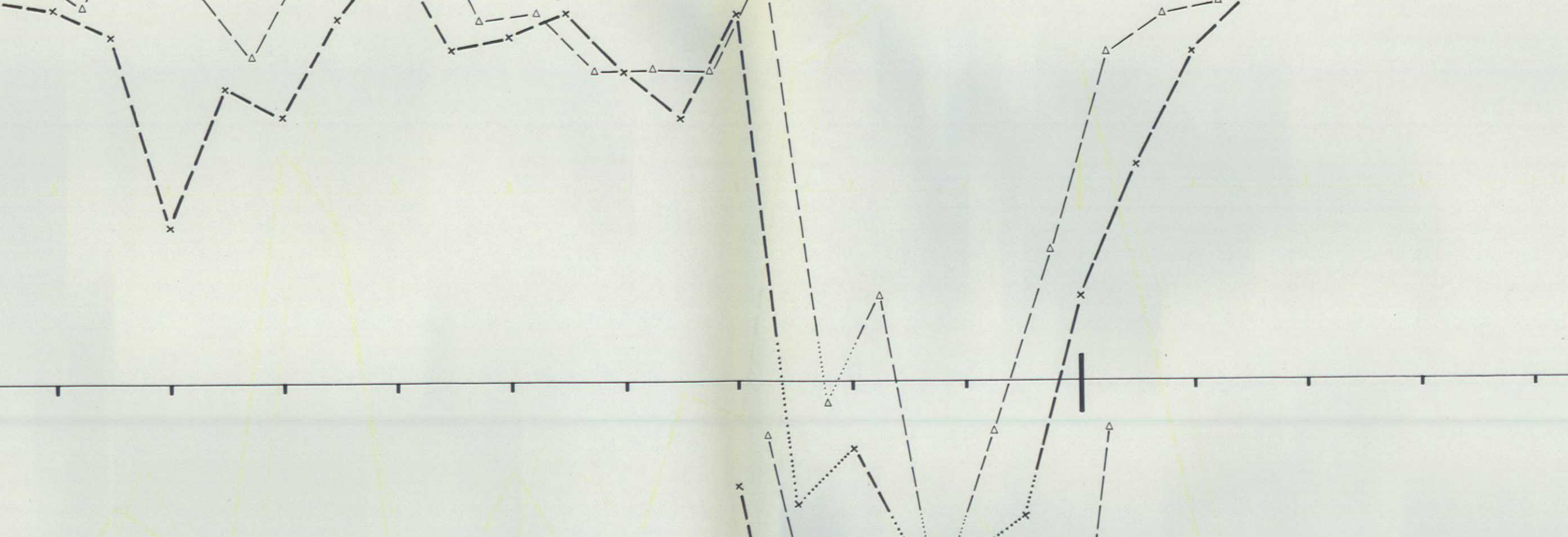

L-15 E

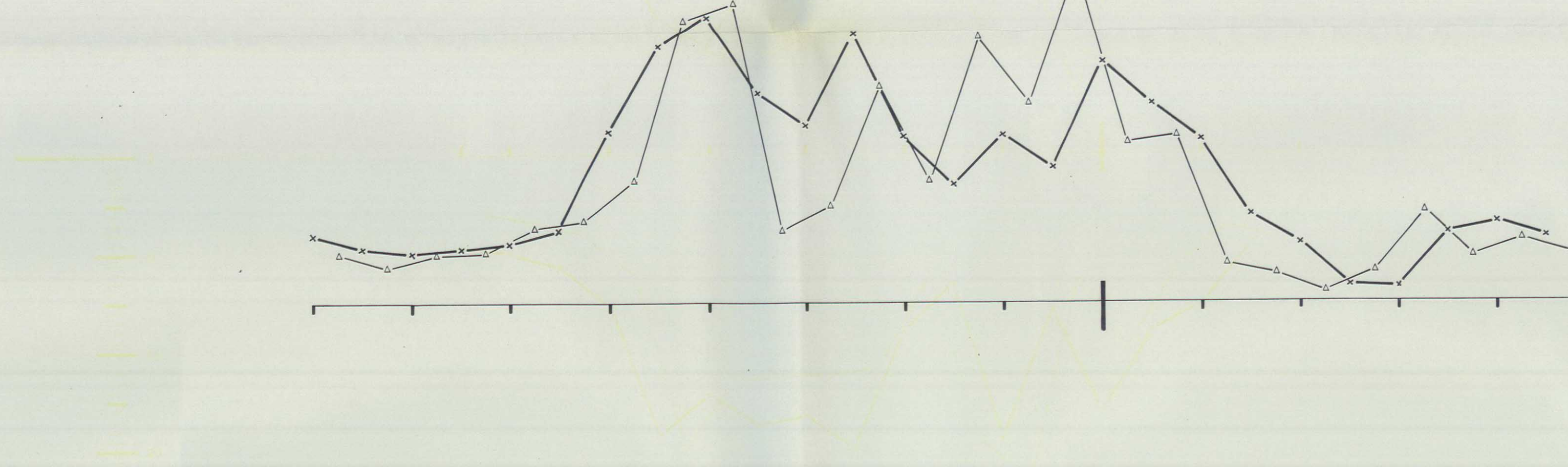
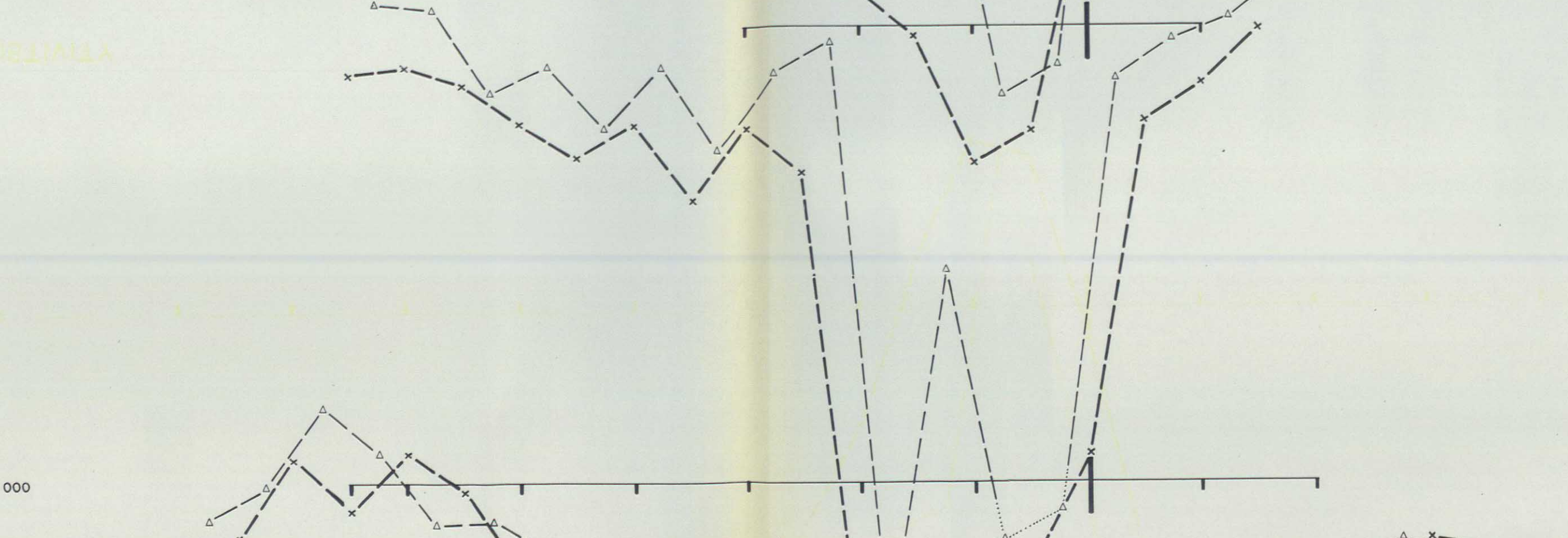

L-2 E

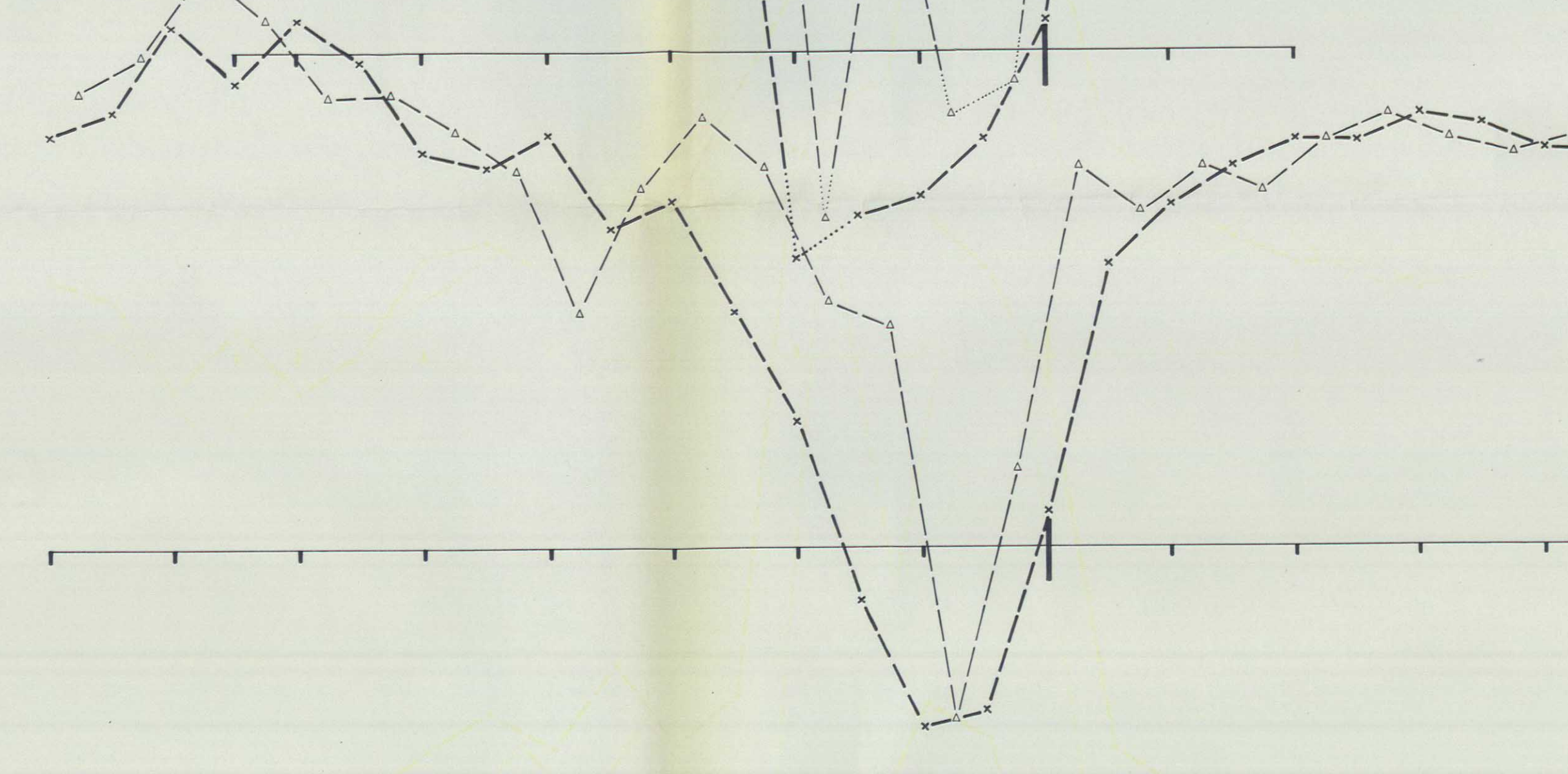
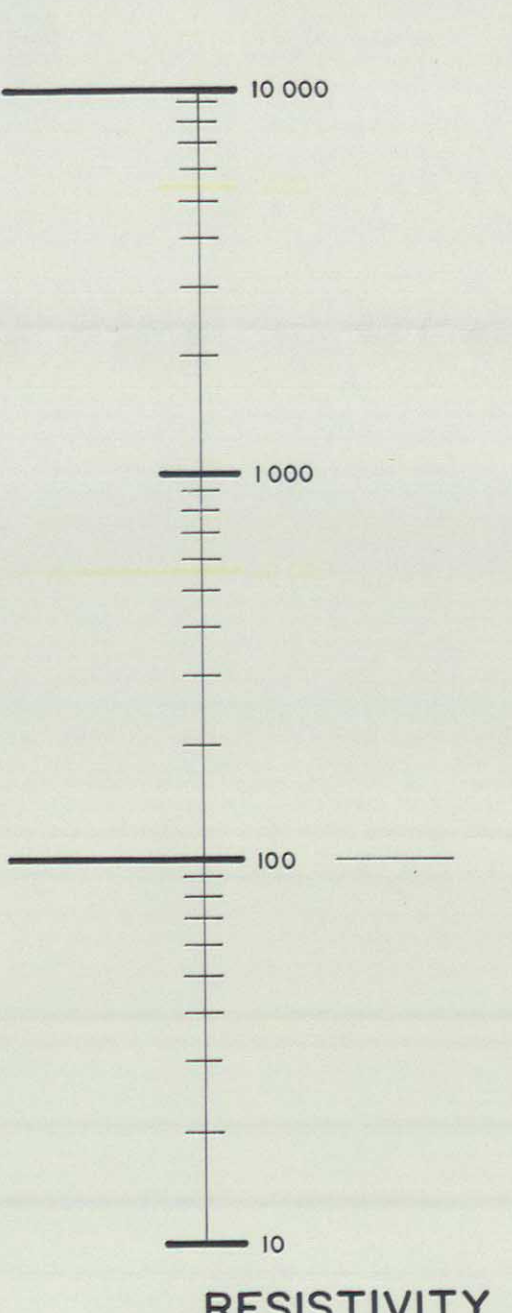

L-3 E

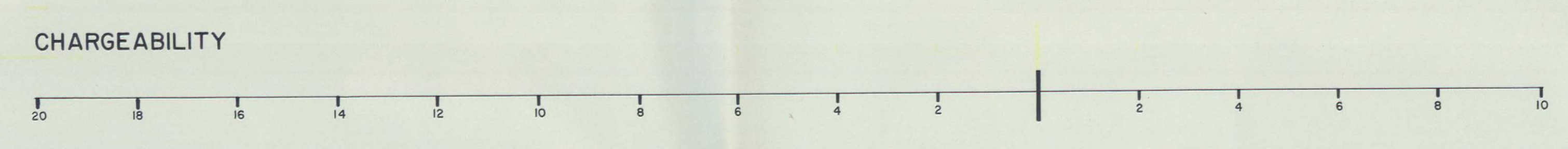

LEGEND

CHARGEABILITY SCALE 1 mA = 10 MILLISECONDS

ELECTRODE SPACING

- 400'
- 200'
- 100'

RESISTIVITY SCALE 2 mA = 1 LOGARITHMIC CYCLE WITH BASETRACE TAKEN AS 100 OHM-METER

ELECTRODE SPACING

- 400'
- 200'
- 100'

GRAVITY SCALE 1" = 0.5 MILLIGAL

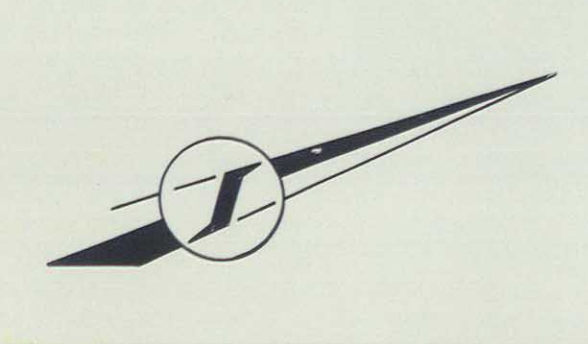

NOTES

SCHLITZER WA-VII INDUCED POLARIZATION INSTRUMENTATION.

THREE ELECTRODE ARRAY

INTERLINE SPACING NOT TO SCALE.

PLATE 2

SCURRY RAINBOW OIL LIMITED
KENO HILL AREA, YUKON TERRITORY

CHARGEABILITY AND RESISTIVITY PROFILES
OF
INDUCED POLARIZATION SURVEY

SCALE 1" = 200'
BY
SEIGEL ASSOCIATES LIMITED
VANCOUVER B.C.

TO ACCOMPANY A GEOLOGICAL REPORT BY MICHAEL J. LEWIS DATED 25.8.1972	WORK COMPLETED: 11.8.1972 DRAFTED 24.8.1972 BY REC.	JOB NUMBER 887	SHEET NUMBER 1 OF 1
--	---	-------------------	------------------------

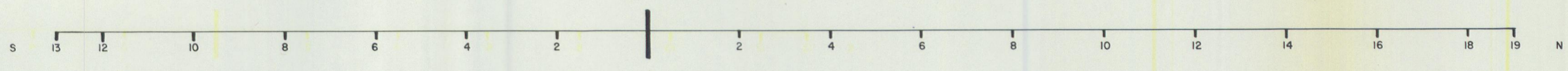

BASELINE

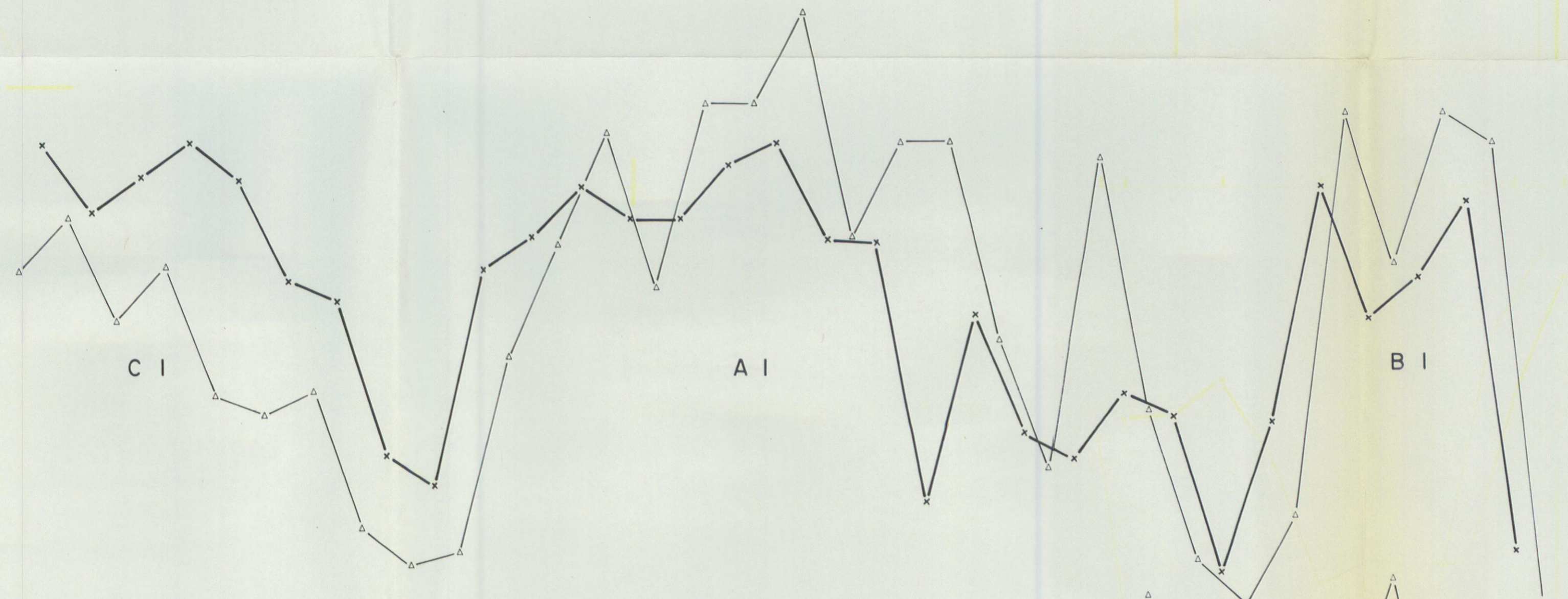

L-48 W

L-52 W

CHARGEABILITY

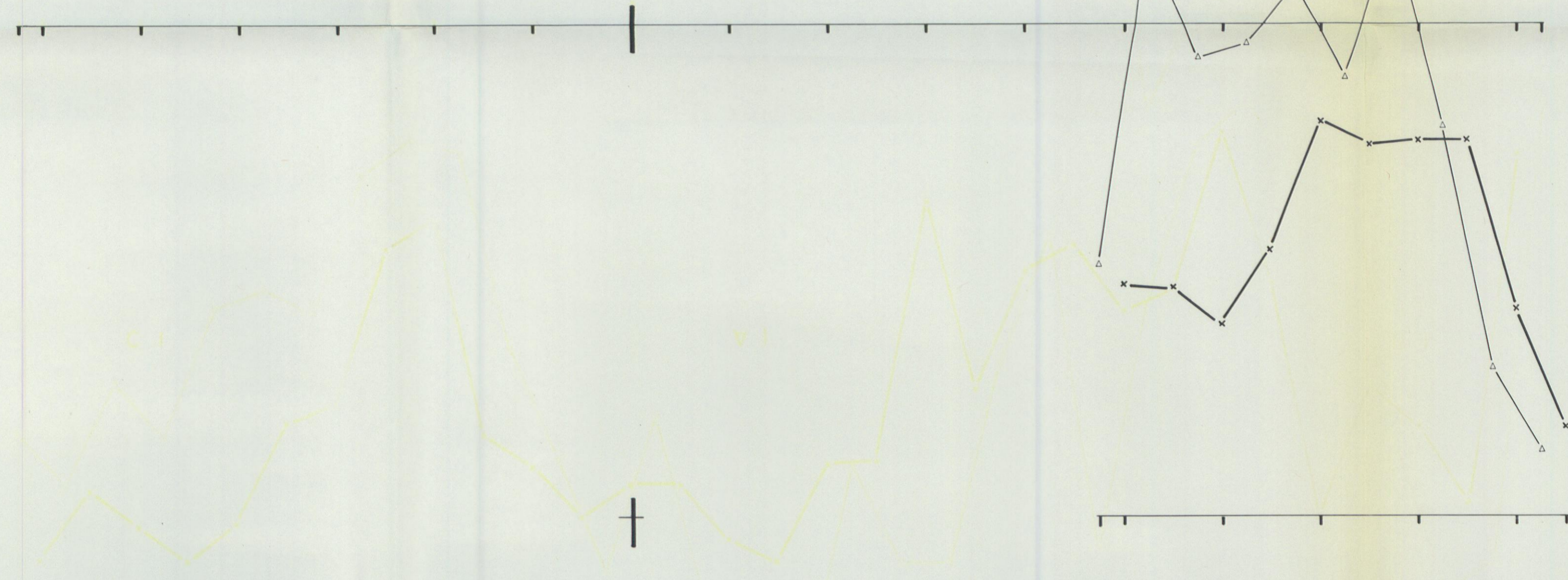

L-48 W

L-52 W

RESISTIVITY

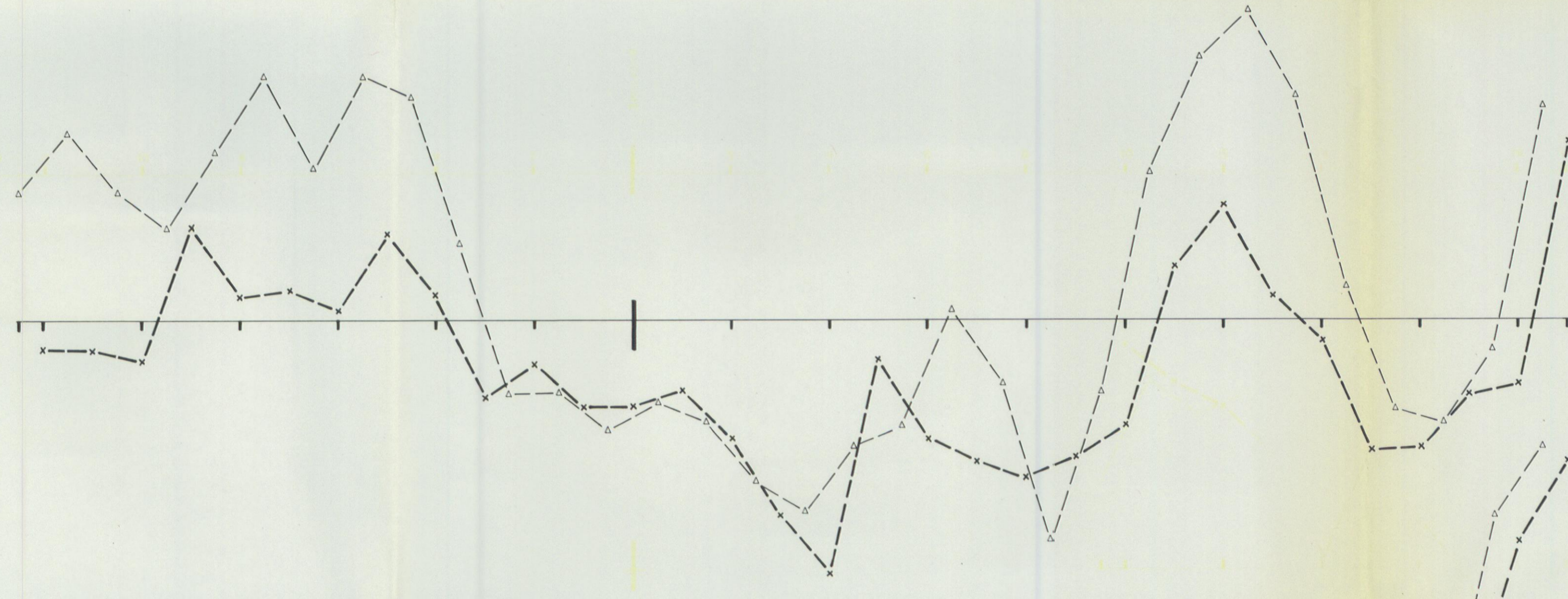

L-48 W

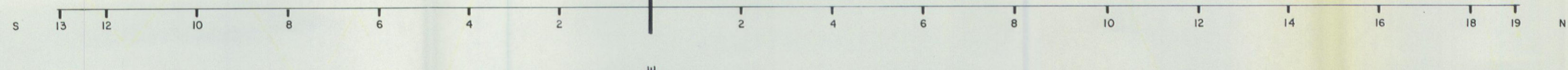

BASELINE

LEGEND

CHARGEABILITY SCALE 1 inch = 10 MILLISECONDS
 ELECTRODE SPACING
 $a = 200'$ — x — x —
 $a = 100'$ — a — a —

RESISTIVITY SCALE: 2 inches = 1 LOGARITHMIC CYCLE WITH BASETRACE
 TAKEN AS 100 OHM-METER
 ELECTRODE SPACING
 $a = 200'$ — x — x — x —
 $a = 100'$ — a — a — a —



NOTES

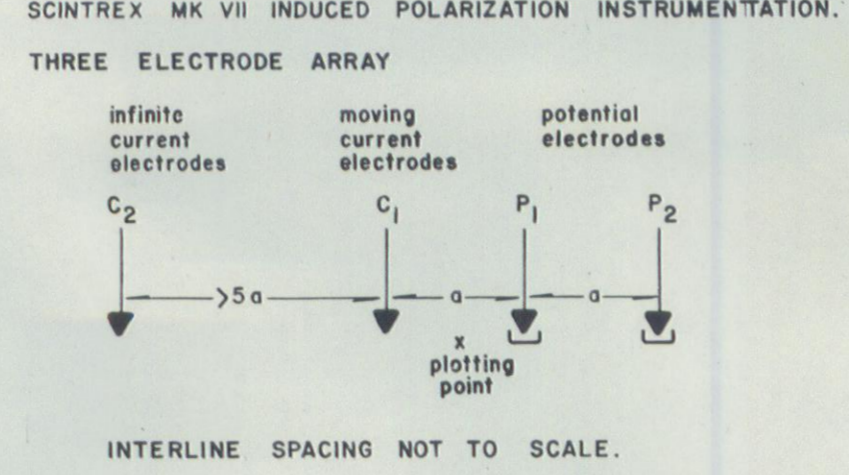
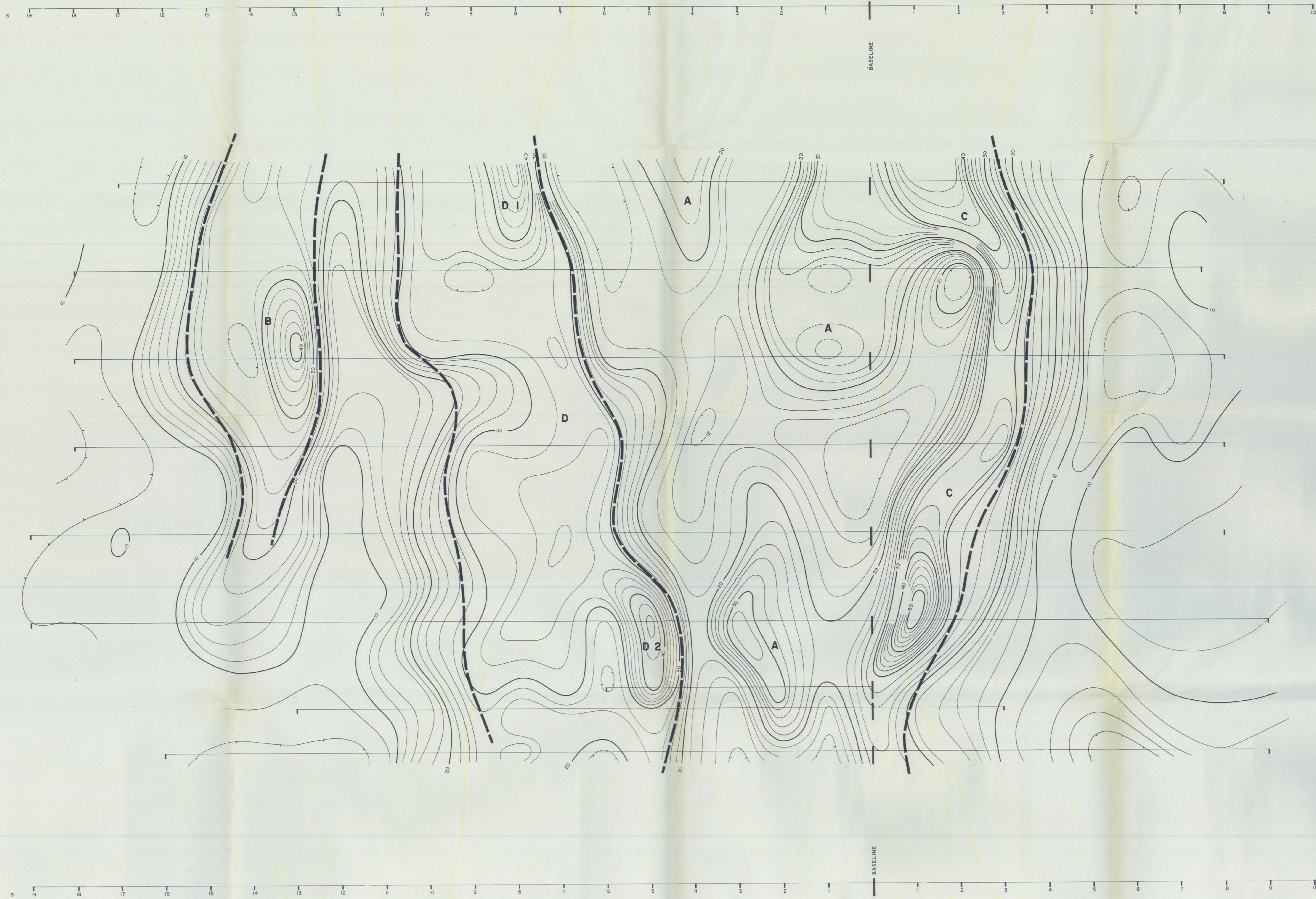

PLATE 3

SCURRY RAINBOW OIL LIMITED
 KENO HILL AREA, YUKON
 TERRITORY

CHARGEABILITY AND RESISTIVITY PROFILES
 OF
 INDUCED POLARIZATION SURVEY

SCALE 1" = 200'
 BY
 SEIGEL ASSOCIATES LIMITED
 VANCOUVER B.C.



LEGEND _____
 2 MILLISECONDS CONTOUR INTERVAL

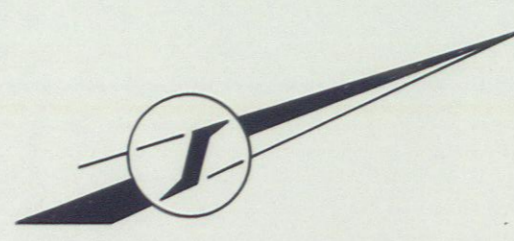

PLATE 4

SCURRY RAINBOW OIL LIMITED
 KENO HILL AREA, YUKON
 TERRITORY

CHARGEABILITY CONTOUR PLAN
 OF
INDUCED POLARIZATION SURVEY

200' ELECTRODE SPACING
 SCALE 1" = 100'

BY
 SEIGEL ASSOCIATES LIMITED
 VANCOUVER B.C.

TO ACCOMPANY A GEOPHYSICAL REPORT BY MICHAEL J. LEWIS	WORK COMPLETED: 11.8.1972 DRAFTED: 23.8.1972 et REV:	JOB NUMBER 887	SHEET NUMBER 1 OF 1
DATED 25.8.1972			

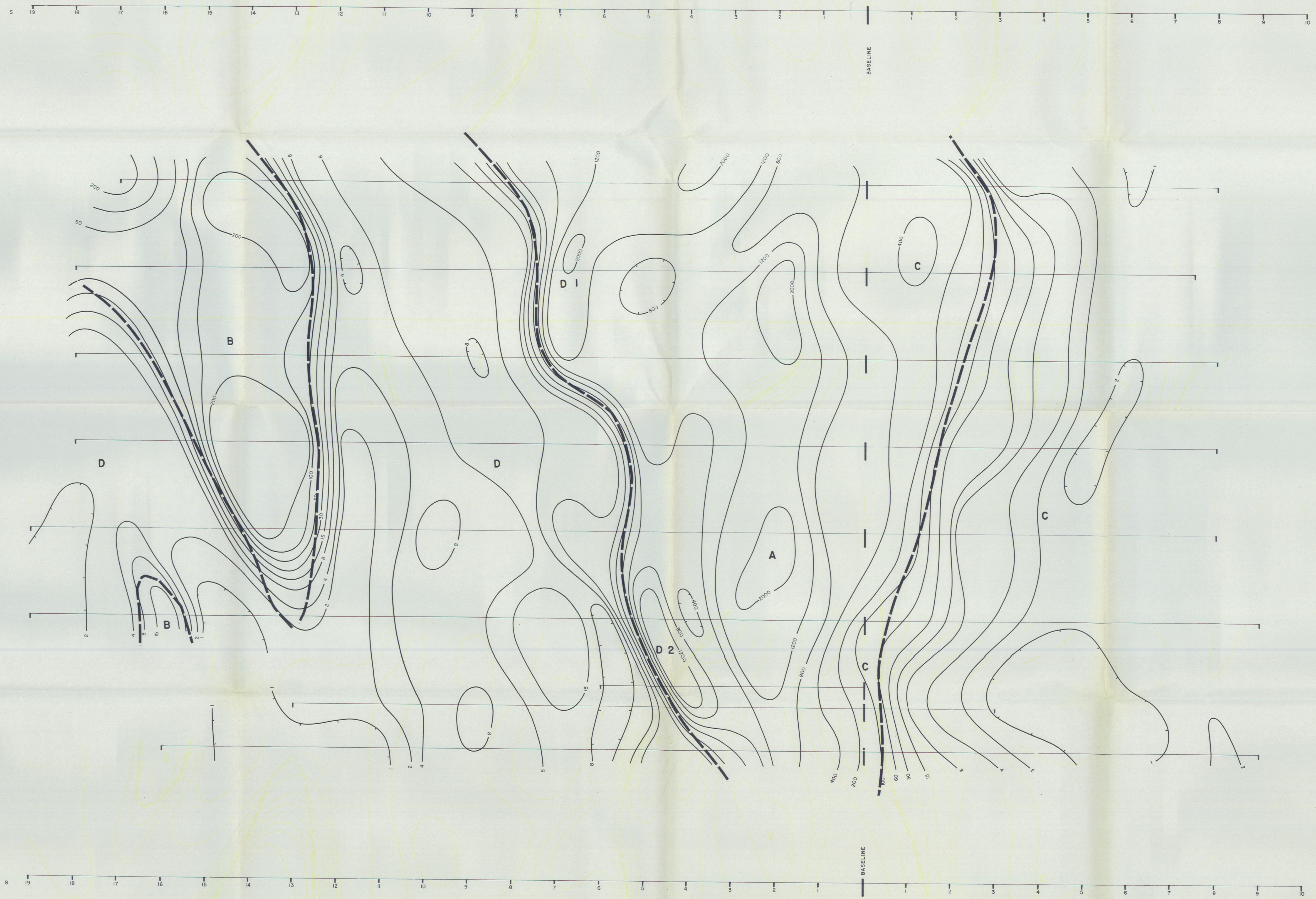

LEGEND _____
 MODIFIED LOGARITHMIC CONTOUR INTERVAL
 AS INDICATED.

PLATE 6
SCURRY RAINBOW OIL LIMITED
 KENO HILL AREA, YUKON
 TERRITORY

"METAL FACTOR" CONTOUR PLAN
 OF
INDUCED POLARIZATION SURVEY

200' ELECTRODE SPACING
 SCALE 1" = 100'
 BY
 SEIGEL ASSOCIATES LIMITED
 VANCOUVER B.C.

TO ACCOMPANY A GEOPHYSICAL REPORT BY MICHAEL J. LEWIS DATED: 25.8.1972	WORK COMPLETED: 11.8.1972 DRAFTED: 23.8.1972 of REV.	JOB NUMBER 887	SHEET NUMBER 1 OF 1
--	--	-------------------	------------------------