

019119

REPORT ON THE
INDUCED POLARIZATION
AND RESISTIVITY SURVEY
JOY AND PHIL CLAIMS
SKUKUM CREEK AREA, WHEATON DISTRICT
YUKON TERRITORY
FOR
YUKON ANTIMONY CORP. LTD. (N.P.L.)

McPHAR GEOPHYSICS LIMITED
REPORT ON THE
INDUCED POLARIZATION
AND RESISTIVITY SURVEY
JOY AND PHIL CLAIMS
SKUKUM CREEK AREA, WHEATON DISTRICT
YUKON TERRITORY
FOR
YUKON ANTIMONY CORP. LTD. (N.P.L.)

1. INTRODUCTION

As authorized by Yukon Antimony Corporation Ltd. (N.P.L.) an induced polarization and resistivity survey has been carried out over parts of the Company's Joy and Phil claim groups. These claims are located in the Skukum Creek Area, Wheaton District, Southern Yukon Territory.

The purpose of the surveying was to outline any areas of metallic mineralization in the hope that it might be similar to that observed in the Skukum Creek Copper Deposit. This area of mineralization is located near 12S on the base line and is reported by M. P. Stadnyk to consist of chalcopyrite, malachite and azurite disseminated throughout altered granites. Mr. Stadnyk estimates 3 million tons of 0.5 per cent copper from the exposed portion of the deposit and the geology indicates that the deposit could continue under volcanic capping.

The IP field surveying was carried out during June and July 1967.

2. PRESENTATION OF RESULTS

The induced polarization and resistivity results are shown on the following enclosed data plots. The results are plotted in the manner described in the notes preceding this report.

MAIN GRID

Line No.	Electrode Intervals	Dwg. No.
Base Line (N-S)	300 Foot	IP 2722-1
6S	300 Foot	IP 2722-2
3S	300 Foot	IP 2722-3
0	300 Foot	IP 2722-4
5N	300 Foot	IP 2722-5
10N	300 Foot	IP 2722-6
15N	300 Foot	IP 2722-7
20N	300 Foot	IP 2722-8
25N	300 Foot	IP 2722-9
40N	300 Foot	IP 2722-10
45N	300 Foot	IP 2722-11
50N	300 Foot	IP 2722-12
55N	300 Foot	IP 2722-13

EXTENSION GRID

Line No.	Electrode Intervals	Dwg. No.
0	300 Foot	IP 2722-14
5S	300 Foot	IP 2722-15
10S	300 Foot	IP 2722-16
Base Line (N-S)	300 Foot	IP 2722-17

Enclosed with this report is Dwg. Misc. 3268, a plan map of the grid area at a scale of 1" = 500'. The definite and possible induced polarization anomalies are indicated by solid and broken bars respectively on this plan map as well as the data plots. These bars represent the surface projection of the anomalous zones as interpreted from the location of the transmitter and receiver electrodes when the anomalous values were measured.

Since the induced polarization measurement is essentially an averaging process, as are all potential methods, it is frequently difficult to exactly pinpoint the source of an anomaly. Certainly, no anomaly can be located with more accuracy than the spread length; i. e. when using 200 foot spreads the position of a narrow body can only be determined to lie between two stations 200 feet apart. In order to locate sources at some depth, larger spreads must be used, with a corresponding increase in the uncertainties of location. Therefore, while the center of the indicated anomaly probably corresponds fairly well with source, the length of the indicated anomaly along the line should not be taken to represent the exact edges of the anomalous

material.

3. DISCUSSION OF RESULTS

The surveying was carried out on two sets of lines which are known as the Main Grid and the Extension Grid. These grids are separated by approximately 1200 feet as indicated on the plan map and the Skukum Creek Copper Deposit is located on a steep slope that separates them.

Main Grid

No strong IP effects indicative of heavy concentrations of metallic mineralization are evident on this grid. However, a number of weaker anomalies appear to outline an anomalous zone that trends north-south in the vicinity of the base line. This feature has been designated Zone A. The sulphide content is difficult to estimate, but it probably does not exceed 5 per cent. Although the magnitude of the apparent metal factor values is not large, the interpreted anomalies are based on values that range from 4 to 10 times background.

Base Line

The strongest IP effects on Zone A occur between 3N and 6N and indicate a shallow source of low to moderate metallic content that probably extends to depth. This is flanked both north and south by smaller metal factor values which suggest that the shallow mineralization weakens in both directions. Stronger IP effects on the $n = 3$ data from 0 to 6S are typical of a source that is remote from the line (i.e. either

at depth or to the side of the traverse) and the mineralization may improve with depth in this vicinity. The single higher value between 3S and 6S could be caused by a narrow more concentrated source, but detailed surveying within shorter electrodes would be required to assess its importance.

Zone A may represent mineralization similar to the Skukum Creek Copper Deposit that lies near 12S. It is definitely worthy of a testing. A vertical hole, collared at 4+50N on the Base Line and drilled to a depth of 750 feet is recommended for this purpose.

Line 6S

A shallow and possibly narrow, source is indicated by the results to lie between 3E and 6E. Surveying with shorter electrode intervals would be required to pinpoint its location for drilling.

Line 3S

On this line the source is remote and may be located at depth. However, some of the effects could be due to a source lying to the north. Line 3S may be close to the southern edge of Zone A.

Line 0

A broad source of low to moderate metallic content appears to be located at a depth of about 200 feet with its strongest portion between 0 and 4E.

Lines 5N and 10N

On both of these lines, Zone A appears to be a shallow

source that could be as much as 900 feet wide. The stronger metal factor values between 3E and 6E indicate that the source improves with depth.

Line 15N

The IP effects are quite weak on this line and may indicate the northern limit of Zone A. This interpretation is in close agreement with the results obtained on the N-S Base Line.

Lines 20N, 25N and 40N

There are no IP effects on these lines that are considered significant.

Line 45N

Weak IP effects between 0 and 9E suggest a narrow, shallow source between 0 and 3E as well as a deeper, broader source from 3E to 9E. If the results of drilling Zone A are encouraging, then further work would be warranted in their vicinity. However, additional IP surveying on closer spaced lines would be desirable before spotting a test hole.

Line 50N

Weak, shallow IP effects occur near the Base Line but these were not confirmed on the Base Line data plot. Unless the geology is particularly favourable, no further work appears warranted at present.

Line 55N

There are no significant IP effects on this line.

Extension Grid

Somewhat stronger IP effects occur on the Extension Grid which lies south of the showing. Only four short lines were run in this area and these appear to have outlined an important area of variable metallic content that has been designated Zone B.

Line 0

On this line the IP effects are weak but indicate a remote source that is probably located at depth.

Line 5S

The best response on Zone B extends from 3W to 12W and is typical of a wide, shallow zone of moderate metallic content. Weaker effects extend for a few hundred feet both east and west.

A vertical hole, collared at 5W on Line 5S, drilled to a depth of at least 750 feet, is recommended to test the strongest portion of this interesting anomaly.

Line 10S

Weakly anomalous IP effects extend the full length of the survey data. The increased values near 3E probably represent more concentrated mineralization at depth.

Extension Base Line

A possible anomaly is shown near 2S but the data would have to be extended to determine the extent of the anomaly.

4. SUMMARY AND RECOMMENDATIONS

Two anomalous zones, Zone A and Zone B, have been interpreted from the data on the grids that lie north and south of the Skukum Creek Copper Deposit. Unfortunately, IP surveying could not be carried out directly over this deposit due to the precipitous talus slope.

Zone A is located near the base line on the Main Grid north of the showing. It appears to be due to a source of low to moderate metallic content that measures approximately 1700 feet N-S and 900 feet E-W. While none of the IP effects are particularly strong they are significantly above background and could represent mineralization similar to that observed in the showing. Zone A definitely warrants a drill test and a vertical hole collared at 4+50N on the Base Line has been recommended to establish its cause. Additional drilling will be recommended on the basis of the results obtained in this hole.

Zone B has been formed from the stronger IP effects measured on the Extension Grid that lies south of the showing. The available data on Zone B is quite limited and the anomaly is open to both the north and south. The best IP response occurs near 5W on Line 5S and a vertical hole has been recommended to test the anomaly at this locality. If the results of this initial test hole are encouraging, then additional IP surveying should be done to determine the extent

of Zone B.

The weak effects on the north part of the Main Grid should be reassessed on the basis of the results obtained in drilling Zones A and B.

McPHAR GEOPHYSICS LIMITED

D. B. Sutherland

D. B. Sutherland,
Geophysicist.

Per. M. L.

A. W. Mullan

A. W. Mullan,
Geologist.

Dated: August 23, 1967

McPHAR GEOPHYSICS LIMITED

NOTES ON THE THEORY OF INDUCED POLARIZATION AND THE METHOD OF FIELD OPERATION

Induced Polarization as a geophysical measurement refers to the blocking action or polarization of metallic or electronic conductors in a medium of ionic solution conduction.

This electro-chemical phenomenon occurs wherever electrical current is passed through an area which contains metallic minerals such as base metal sulphides. Normally, when current is passed through the ground, as in resistivity measurements, all of the conduction takes place through ions present in the water content of the rock, or soil, i. e. by ionic conduction. This is because almost all minerals have a much higher specific resistivity than ground water. The group of minerals commonly described as "metallic", however, have specific resistivities much lower than ground waters. The induced polarization effect takes place at those interfaces where the mode of conduction changes from ionic in the solutions filling the interstices of the rock to electronic in the metallic minerals present in the rock.

The blocking action or induced polarization mentioned above, which depends upon the chemical energies necessary to allow the ions to give up or receive electrons from the metallic surface, increases with the time that a d. c. current is allowed to flow through

the rock; i. e. as ions pile up against the metallic interface the resistance to current flow increases. Eventually, there is enough polarization in the form of excess ions at the interfaces to effectively stop all current flow through the metallic particle. This polarization takes place at each of the infinite number of solution-metal interfaces in a mineralized rock.

When the d. c. voltage used to create this d. c. current flow is cut off, the Coulomb forces between the charged ions forming the polarization cause them to return to their normal position. This movement of charge creates a small current flow which can be measured on the surface of the ground as a decaying potential difference.

From an alternate viewpoint it can be seen that if the direction of the current through the system is reversed repeatedly before the polarization occurs, the effective resistivity of the system as a whole will change as the frequency of the switching is changed. This is a consequence of the fact that the amount of current flowing through each metallic interface depends upon the length of time that current has been passing through it in one direction.

The values of the "metal factor" or "M. F." are a measure of the amount of polarization present in the rock mass being surveyed. This parameter has been found to be very successful in mapping areas of sulphide mineralization, even those in which all other geophysical methods have been unsuccessful. The induced polarization measurement is more sensitive to sulphide content than other electrical measurements

because it is much more dependent upon the sulphide content. As the sulphide content of a rock is increased, the "metal factor" of the rock increases much more rapidly than the resistivity decreases.

Because of this increased sensitivity, it is possible to locate and outline zones of less than 10% sulphides that can't be located by E. M. Methods. The method has been successful in locating the disseminated "porphyry copper" type mineralization in the South-western United States.

Measurements and experiments also indicate that it should be possible to locate most massive sulphide bodies at a greater depth with induced polarization than with E. M.

Since there is no I. P. effect from any conductor unless it is metallic, the method is useful in checking E. M. anomalies that are suspected of being due to water filled shear zones or other ionic conductors. There is also no effect from conductive overburden, which frequently confuses E. M. results. It would appear from scale model experiments and calculations that the apparent metal factors measured over a mineralized zone are larger if the material overlying the zone is of low resistivity.

Apropos of this, it should be stated that the induced polarization measurements indicate the total amount of metallic constituents in the rock. Thus all of the metallic minerals in the rock, such as pyrite, as well as the ore minerals chalcopryrite, chalcocite, galena, etc. are responsible for the induced polarization effect. Some

oxides such as magnetite, pyrolusite, chromite, and some forms of hematite also conduct by electrons and are metallic. All of the metallic minerals in the rock will contribute to the induced polarization effect measured on the surface.

In the field procedure, measurements on the surface are made in a way that allows the effects of lateral changes in the properties of the ground to be separated from the effects of vertical changes in the properties. Current is applied to the ground at two points a distance (X) apart. The potentials are measured at two other points (X) feet apart, in line with the current electrodes. The distance between the nearest current and potential electrodes is an integer number (N) times the basic distance (X).

The measurements are made along a surveyed line, with a constant distance (NX) between the nearest current and potential electrodes. In most surveys, several traverses are made with various values of (N); i. e. (N) = 1, 2, 3, 4, etc. The kind of survey required (detailed or reconnaissance) decides the number of values of (N) used.

In plotting the results, the values of the apparent resistivity and the apparent metal factor measured for each set of electrode positions are plotted at the intersection of grid lines, one from the center point of the current electrodes and the other from the center point of the potential electrodes. The resistivity values are plotted above the line and the metal factor values below. The lateral displacement of a given value is determined by the location along the survey

line of the center point between the current and potential electrodes. The distance of the value from the line is determined by the distance (NX) between the current and potential electrodes when the measurement was made.

The separation between sender and receiver electrodes is only one factor which determines the depth to which the ground is being sampled in any particular measurement. These plots then, when contoured, are not section maps of the electrical properties of the ground under the survey line. The interpretation of the results from any given survey must be carried out using the combined experience gained from field, model and theoretical investigations. The position of the electrodes when anomalous values are measured must be used in the interpretation.

In the field procedure, the interval over which the potential differences are measured is the same as the interval over which the electrodes are moved after a series of potential readings has been made. One of the advantages of the induced polarization method is that the same equipment can be used for both detailed and reconnaissance surveys merely by changing the distance (X) over which the electrodes are moved each time. In the past, intervals have been used ranging from 100 feet to 1000 feet for (X). In each case, the decision as to the distance (X) and the values of (N) is largely determined by the expected size of the mineral deposit being sought, the size of the expected anomaly and the speed with which it is desired to progress.

The diagram in Figure 1 below demonstrates the method used in plotting the results. Each value of the apparent resistivity and the apparent "Metal factor" is plotted and identified by the position of the four electrodes when the measurement was made. It can be seen that the values measured for the larger values of (n) are plotted farther from the line indicating that the thickness of the layer of the earth that is being tested is greater than for the smaller values of (n); i. e. the depth of the measurement is increased.

METHOD USED IN PLOTTING DIPOLE-DIPOLE
INDUCED POLARIZATION AND RESISTIVITY RESULTS

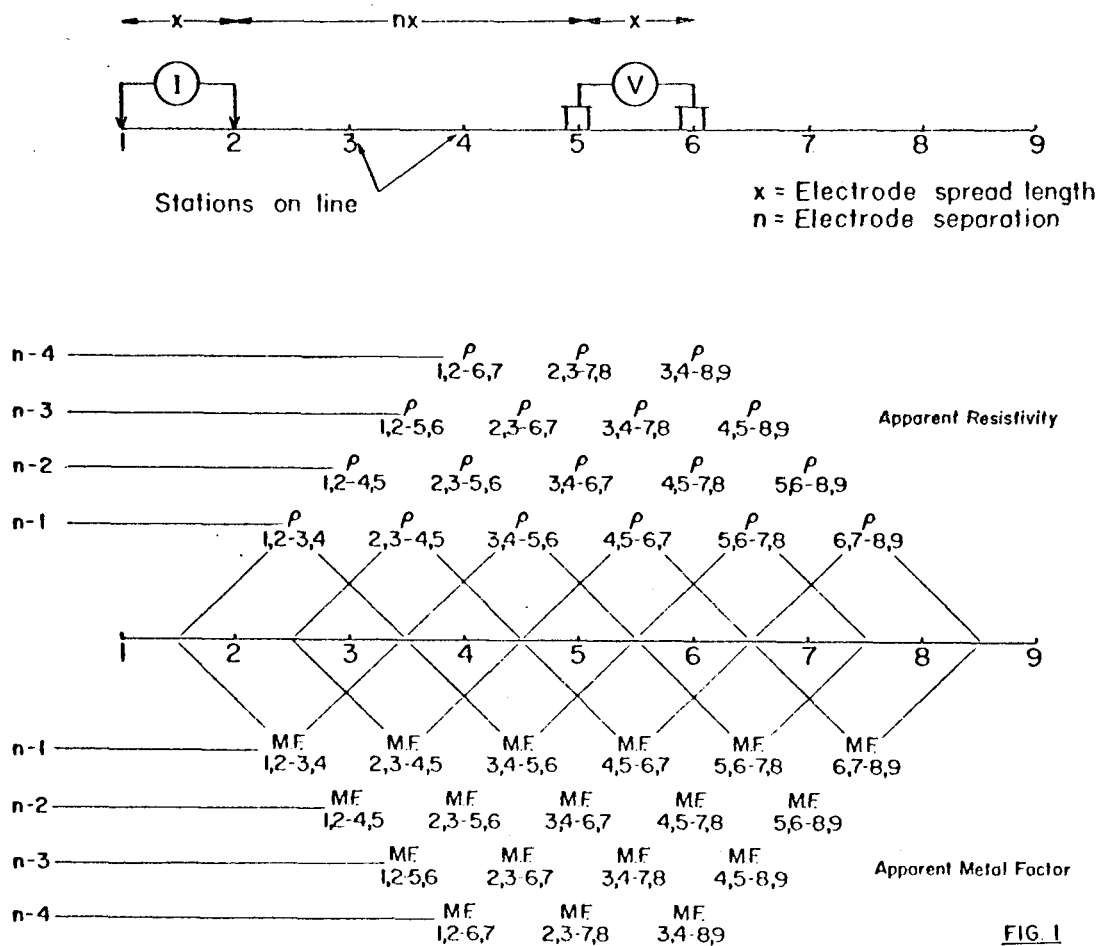
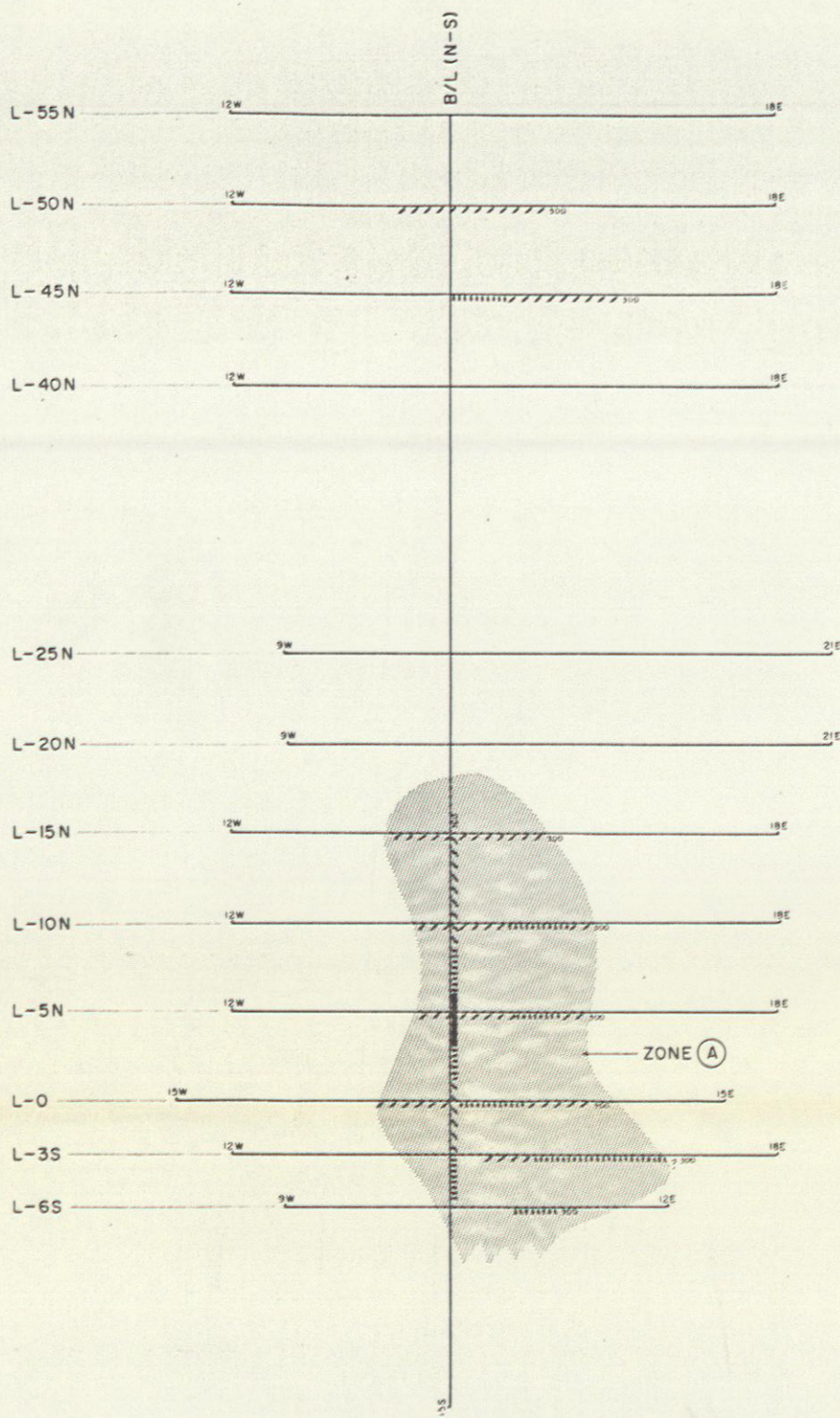

FIG. 1

McPHAR GEOPHYSICS LIMITED
 INDUCED POLARIZATION AND RESISTIVITY SURVEY
 PLAN MAP

DWG. MISC. 3268

MAIN GRID



EXTENSION GRID

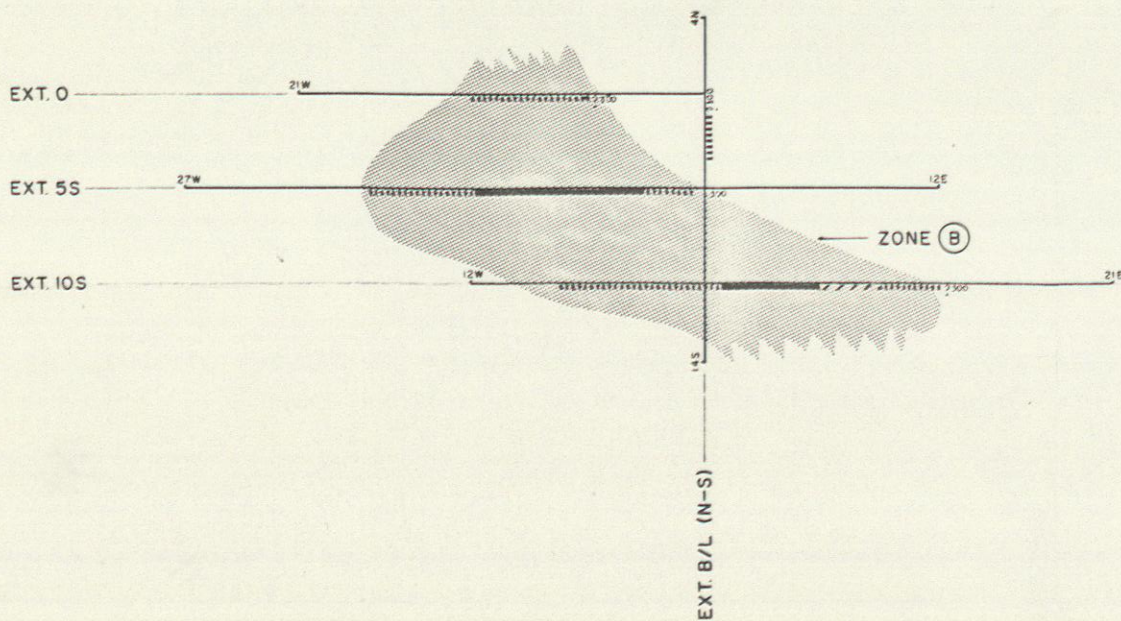

SURFACE PROJECTION
 OF ANOMALOUS ZONES

DEFINITE —————
 PROBABLE - - - - -
 POSSIBLE / / / / /
 Numbers at the end of the
 anomalies indicate spread used.

YUKON ANTIMONY CORPORATION LTD. (N.P.L.)

SKUKUM CREEK PROPERTY, YUKON TERRITORY.

(PHIL CLAIMS) — (JOY CLAIMS)

SCALE

ONE INCH EQUALS FIVE HUNDRED FEET



DRAWN: P.C.
 DATE: AUGUST, 1967
 APPROVED: [Signature]
 DATE: 11/2/67

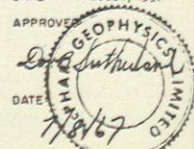

DWG. MISC. 3268

McPHAR GEOPHYSICS LIMITED

INDUCED POLARIZATION AND RESISTIVITY SURVEY

NOTE: CONTOURS AT LOGARITHMIC MULTIPLES OF 10-15-20-30-50-75-100

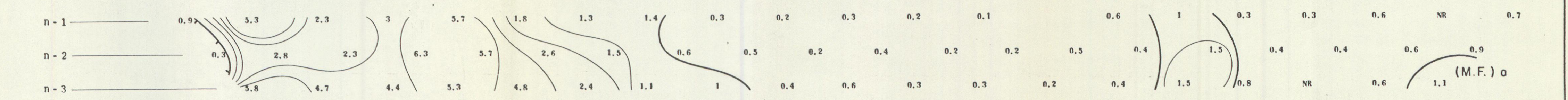
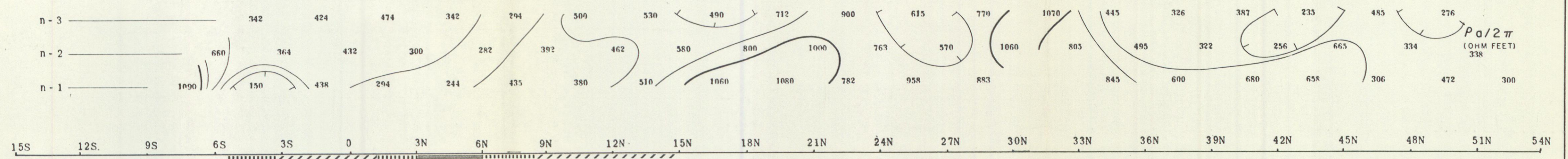
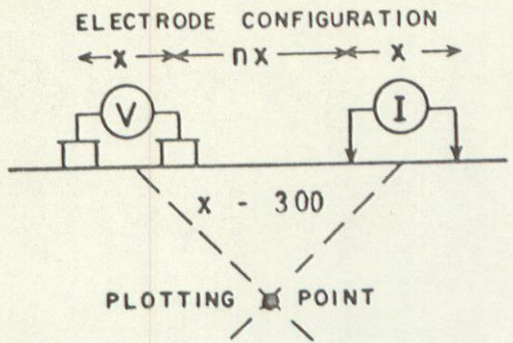

SURFACE PROJECTION OF ANOMALOUS ZONES

DEFINITE

PROBABLE

POSSIBLE

YUKON ANTIMONY CORPORATION LTD. (N.P.L.)

SKUKUM CREEK PROPERTY, YUKON TERRITORY.

(JOY CLAIMS) — (PHIL CLAIMS)

Scale - One inch = 300 Feet

NOTE LOGARITHMIC CONTOUR INTERVAL

FREQUENCY 0.3-5.0 CPS

DATE SURVEYED JULY 1967

APPROVED

DATE 7/18/67



LINE NO. - BASELINE

McPHAR GEOPHYSICS LIMITED

INDUCED POLARIZATION AND RESISTIVITY SURVEY

NOTE: CONTOURS AT LOGARITHMIC MULTIPLES OF 10-15-20-30-50-75-100

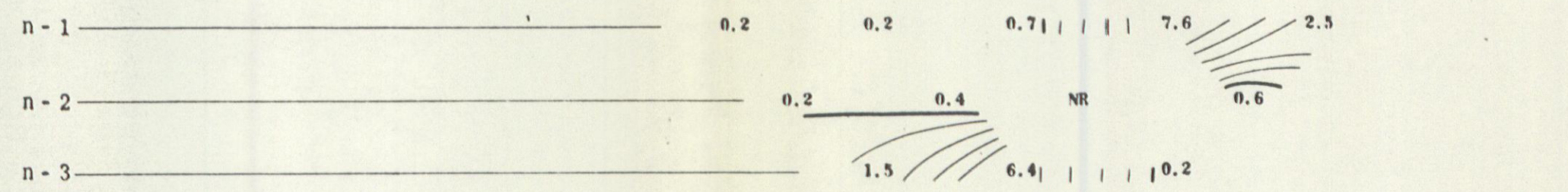
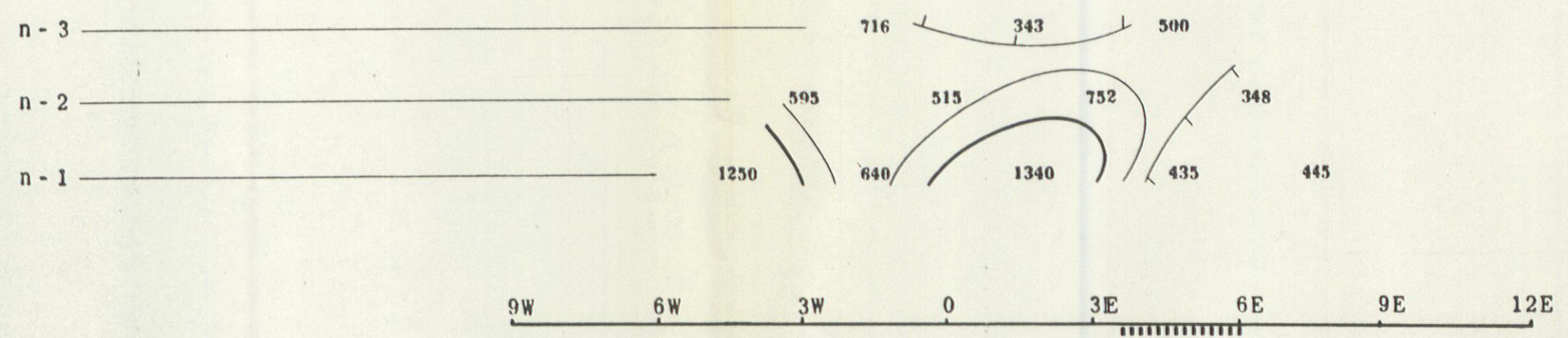
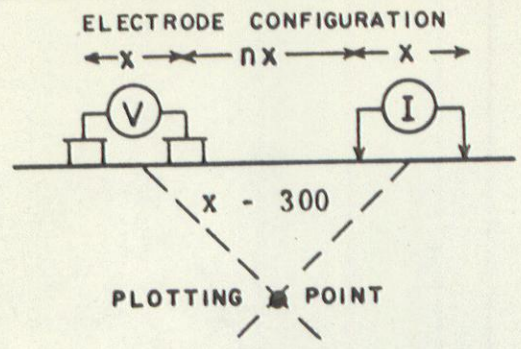

YUKON ANTIMONY CORPORATION LTD. (N.P.L.)

SKUKUM CREEK PROPERTY, YUKON TERRITORY.

(JOY CLAIMS)

Scale - One inch = 300 Feet

NOTE: LOGARITHMIC CONTOUR INTERVAL

SURFACE PROJECTION OF ANOMALOUS ZONES

DEFINITE

PROBABLE

POSSIBLE

FREQUENCY 0.3-5.0 CPS

DATE SURVEYED JULY 1967

APPROVED

DATE 7/18/67

LINE NO.-6S

McPHAR GEOPHYSICS LIMITED

INDUCED POLARIZATION AND RESISTIVITY SURVEY

NOTE: CONTOURS AT LOGARITHMIC MULTIPLES OF 10-15-20-30-50-75-100

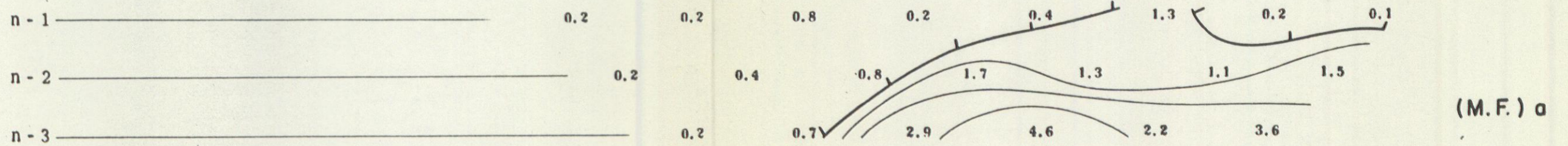
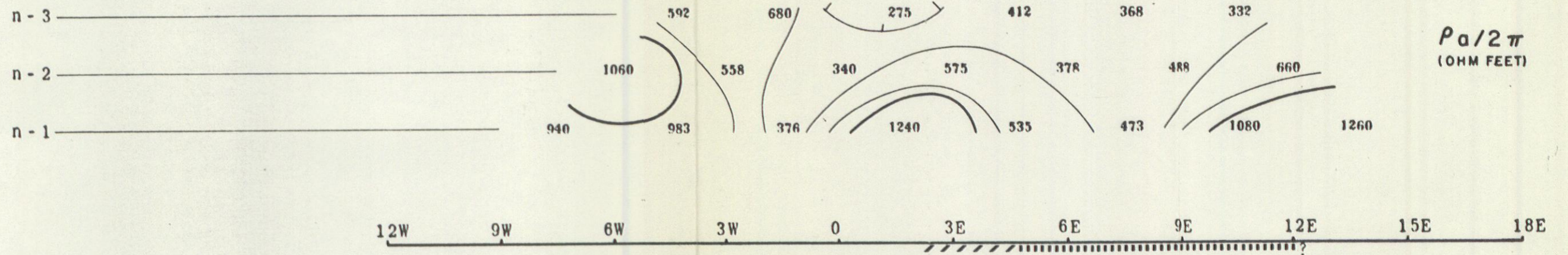
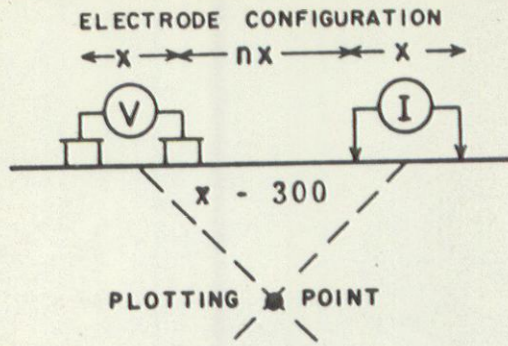

YUKON ANTIMONY CORPORATION LTD. (N.P.L.)

SKUKUM CREEK PROPERTY, YUKON TERRITORY.

(JOY CLAIMS)

Scale - One inch = 300 Feet

NOTE: LOGARITHMIC CONTOUR INTERVAL

SURFACE PROJECTION OF ANOMALOUS ZONES

- DEFINITE
- PROBABLE
- POSSIBLE

FREQUENCY 0.3-5.0 CPS

DATE SURVEYED JULY 1967

APPROVED

DATE 7/18/67

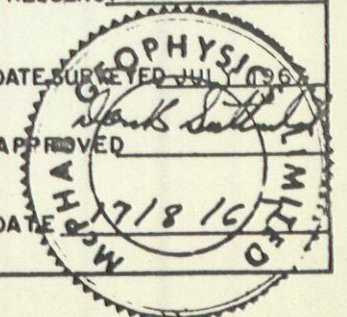

LINE NO.-3S

McPHAR GEOPHYSICS LIMITED

INDUCED POLARIZATION AND RESISTIVITY SURVEY

NOTE: CONTOURS AT LOGARITHMIC MULTIPLES OF 10-15-20-30-50-75-100

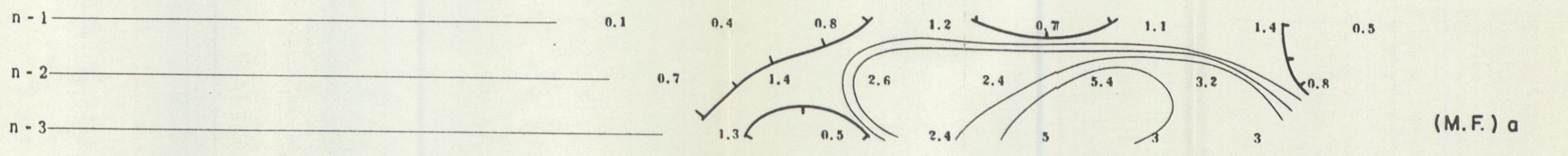
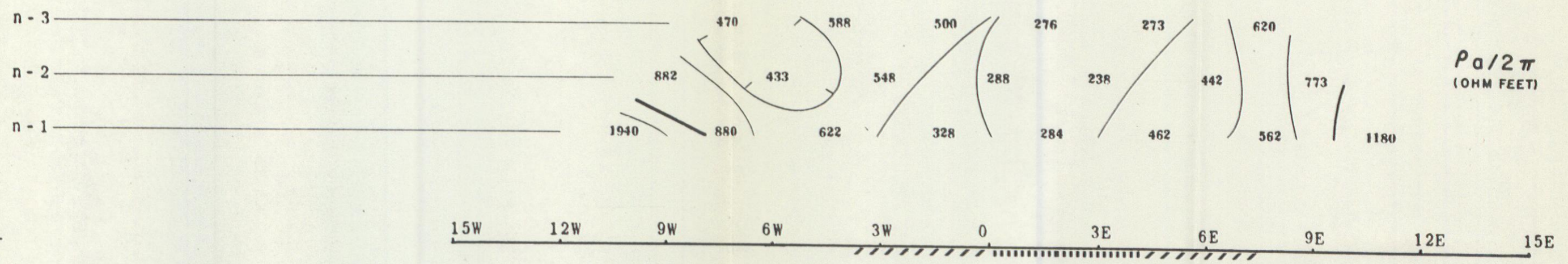
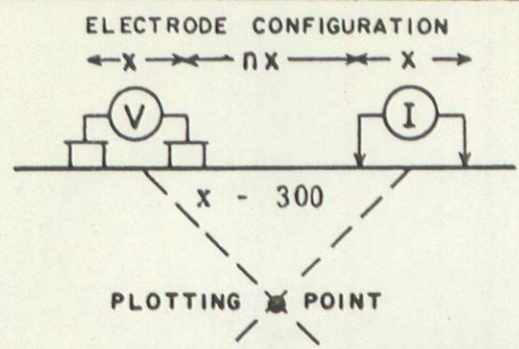

YUKON ANTIMONY CORPORATION LTD. (N.P.L.)

SKUKUM CREEK PROPERTY, YUKON TERRITORY.

(JOY CLAIMS)

Scale - One inch = 300 Feet

NOTE: LOGARITHMIC CONTOUR INTERVAL

SURFACE PROJECTION OF ANOMALOUS ZONES

DEFINITE

PROBABLE

POSSIBLE

FREQUENCY 0.3-5.0 CPS

DATE SURVEYED JULY 1967

APPROVED

DATE 7/18/67

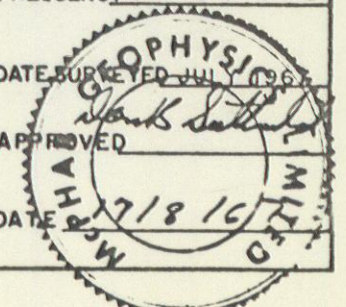

LINE NO.-0

McPHAR GEOPHYSICS LIMITED

INDUCED POLARIZATION AND RESISTIVITY SURVEY

NOTE: CONTOURS AT LOGARITHMIC MULTIPLES OF 10-15-20-30-50-75-100

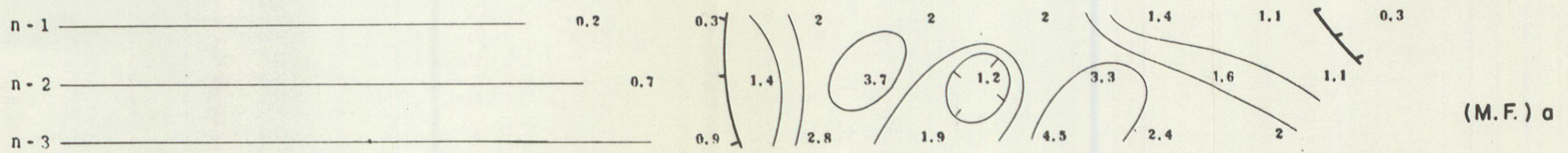
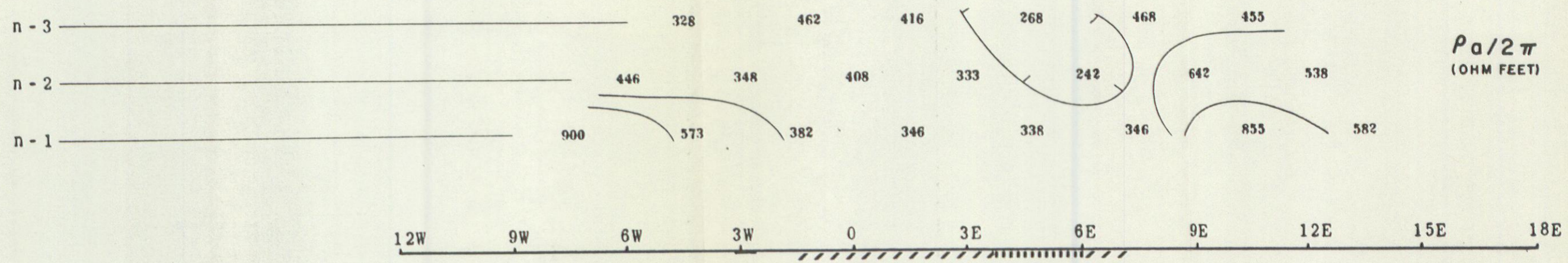
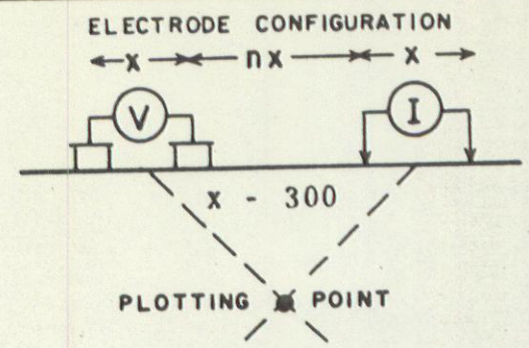

YUKON ANTIMONY CORPORATION LTD. (N.P.L.)

SKUKUM CREEK PROPERTY, YUKON TERRITORY.
(JOY CLAIMS)

Scale - One inch = 300 Feet

NOTE: LOGARITHMIC CONTOUR INTERVAL

SURFACE PROJECTION OF ANOMALOUS ZONES

DEFINITE

PROBABLE

POSSIBLE

FREQUENCY 0.3-5.0 CPS

DATE SURVEYED JUL 1967

APPROVED *[Signature]*

DATE 7/18/67

LINE NO.-5N

McPHAR GEOPHYSICS LIMITED

INDUCED POLARIZATION AND RESISTIVITY SURVEY

NOTE: CONTOURS AT LOGARITHMIC MULTIPLES OF 10-15-20-30-50-75-100

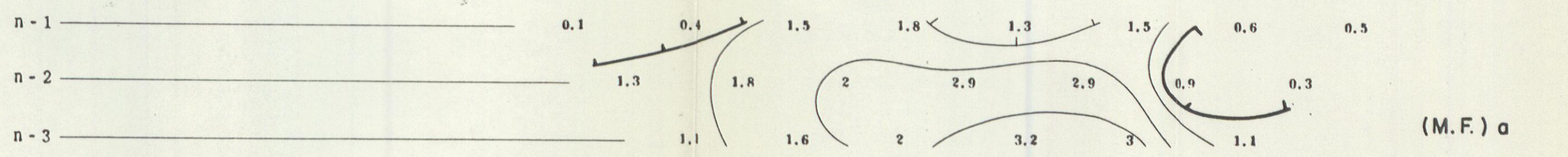
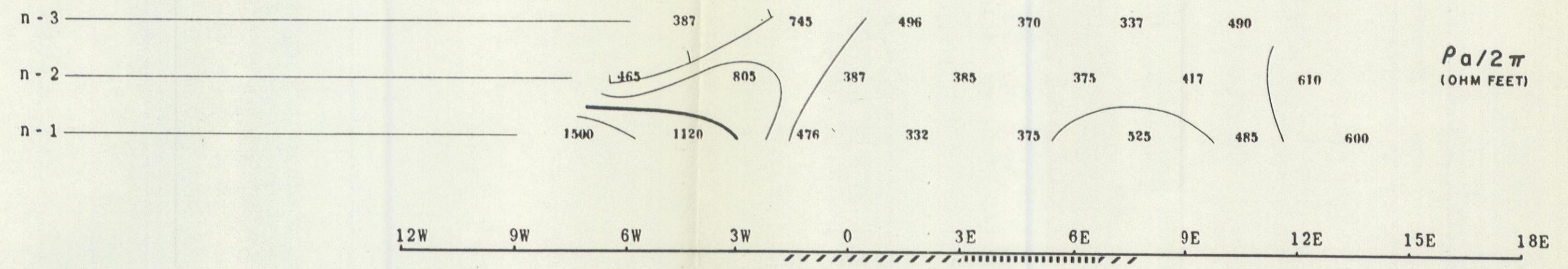
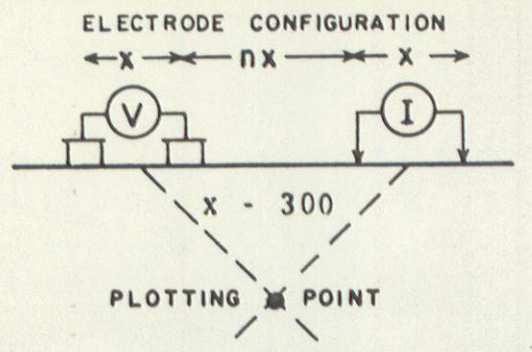

YUKON ANTIMONY CORPORATION LTD. (N.P.L.)

SKUKUM CREEK PROPERTY, YUKON TERRITORY.

(NOY CLAIMS)

Scale - One inch = 300 Feet

NOTE: LOGARITHMIC CONTOUR INTERVAL

SURFACE PROJECTION OF ANOMALOUS ZONES

DEFINITE

PROBABLE

POSSIBLE

FREQUENCY 0.3-5.0 CPS

DATE SURVEYED JULY 1962

APPROVED

DATE 7/18/62

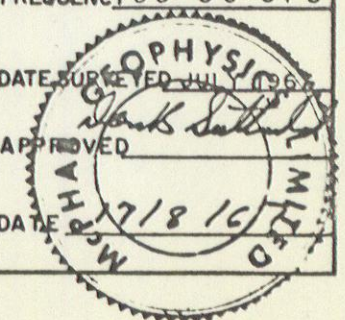

LINE NO. - 10 N

McPHAR GEOPHYSICS LIMITED

INDUCED POLARIZATION AND RESISTIVITY SURVEY

NOTE: CONTOURS AT LOGARITHMIC MULTIPLES OF 10-15-20-30-50-75-100

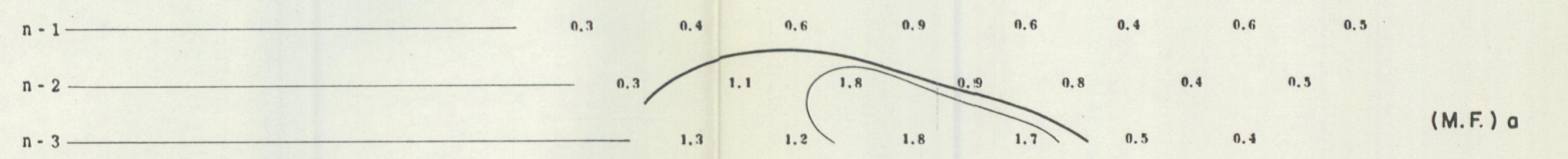
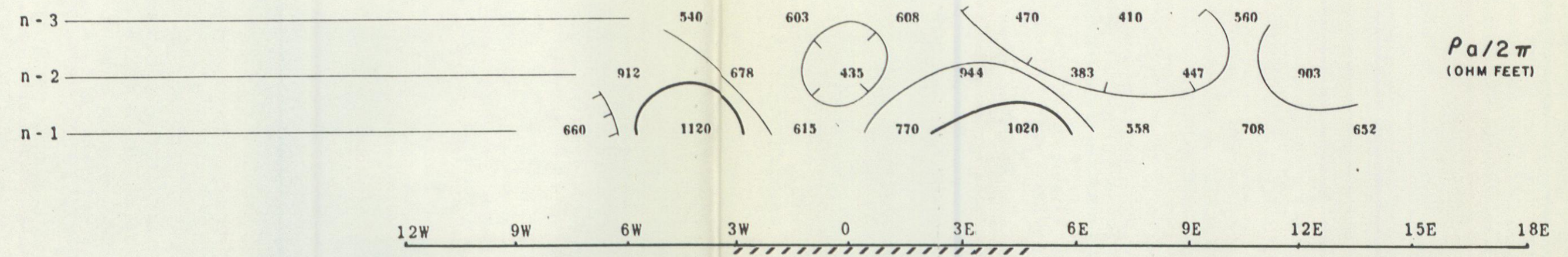
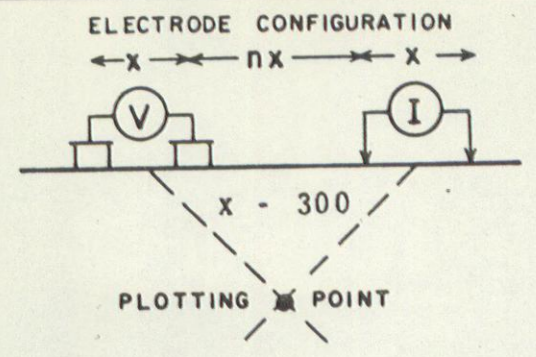

YUKON ANTIMONY CORPORATION LTD. (N.P.L.)

SKUKUM CREEK PROPERTY, YUKON TERRITORY.
 (JOY CLAIMS)

Scale - One inch = 300 Feet

NOTE: LOGARITHMIC CONTOUR INTERVAL

SURFACE PROJECTION OF ANOMALOUS ZONES

DEFINITE

PROBABLE

POSSIBLE

FREQUENCY 0.3-5.0 CPS

DATE SURVEYED JULY 1967

APPROVED

DATE 7/18/67

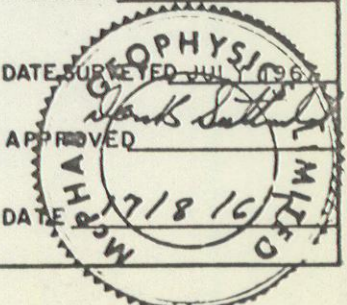

LINE NO.-15N

McPHAR GEOPHYSICS LIMITED

INDUCED POLARIZATION AND RESISTIVITY SURVEY

NOTE: CONTOURS AT LOGARITHMIC MULTIPLES OF 10-15-20-30-50-75-100

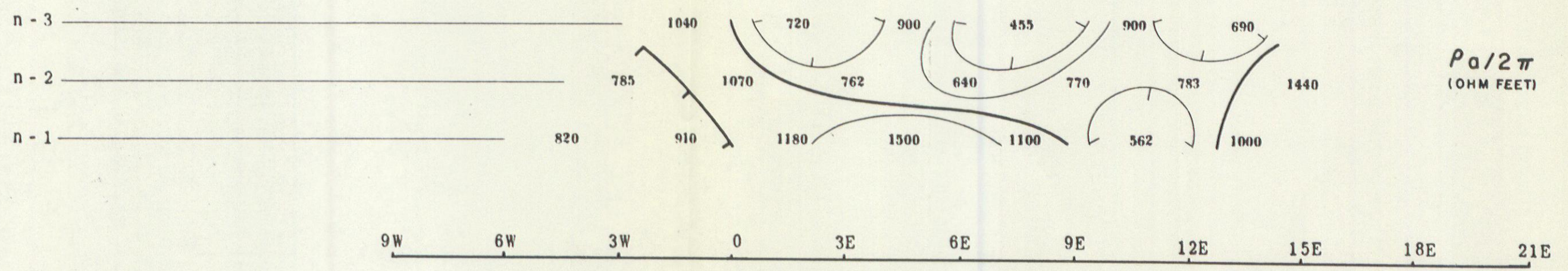
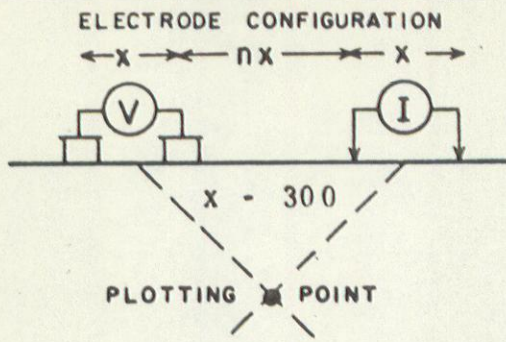

n - 1	0.2	0.1	0.4	0.3	0.2	0.2	0.3
n - 2	0.3	0.2	0.7	0.3	0.3	0.1	0.1
n - 3	0.3	0.5	0.4	0.2	0.2	0.3	

(M.F.) a

YUKON ANTIMONY CORPORATION LTD. (N.P.L.)

SKUKUM CREEK PROPERTY, YUKON TERRITORY.

(JOY CLAIMS)

Scale - One inch = 300 Feet

NOTE: LOGARITHMIC CONTOUR INTERVAL

SURFACE PROJECTION OF ANOMALOUS ZONES

DEFINITE

PROBABLE

POSSIBLE

FREQUENCY 0.3-5.0 CPS

DATE SURVEYED JULY 1967

APPROVED

DATE 7/8/67

LINE NO.-20N

McPHAR GEOPHYSICS LIMITED

INDUCED POLARIZATION AND RESISTIVITY SURVEY

NOTE: CONTOURS AT LOGARITHMIC MULTIPLES OF 10-15-20-30-50-75-100

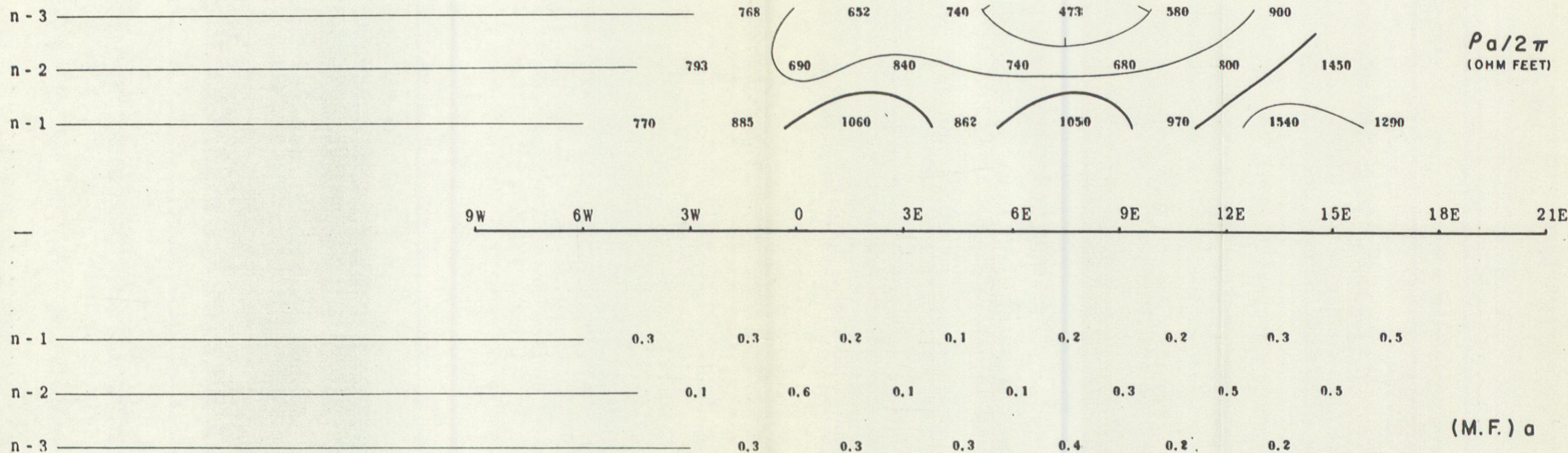
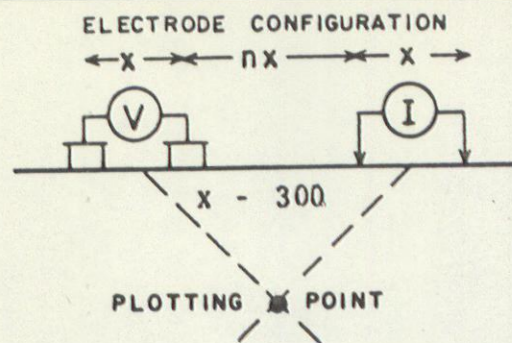

YUKON ANTIMONY CORPORATION LTD. (N.P.L.)

SKUKUM CREEK PROPERTY, YUKON TERRITORY.

(JOY CLAIMS)

Scale - One inch = 300 Feet

NOTE: LOGARITHMIC CONTOUR INTERVAL

SURFACE PROJECTION OF ANOMALOUS ZONES

DEFINITE

PROBABLE

POSSIBLE

FREQUENCY 0.3-5.0 CPS

DATE SURVEYED JULY 1967

APPROVED

DATE 7/18/67

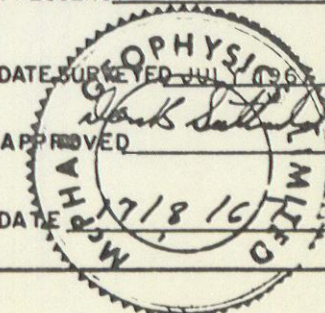

LINE NO.-25 N

McPHAR GEOPHYSICS LIMITED

INDUCED POLARIZATION AND RESISTIVITY SURVEY

NOTE: CONTOURS AT LOGARITHMIC MULTIPLES OF 10-15-20-30-50-75-100

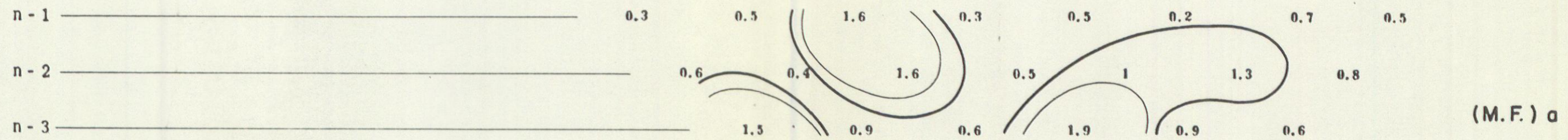
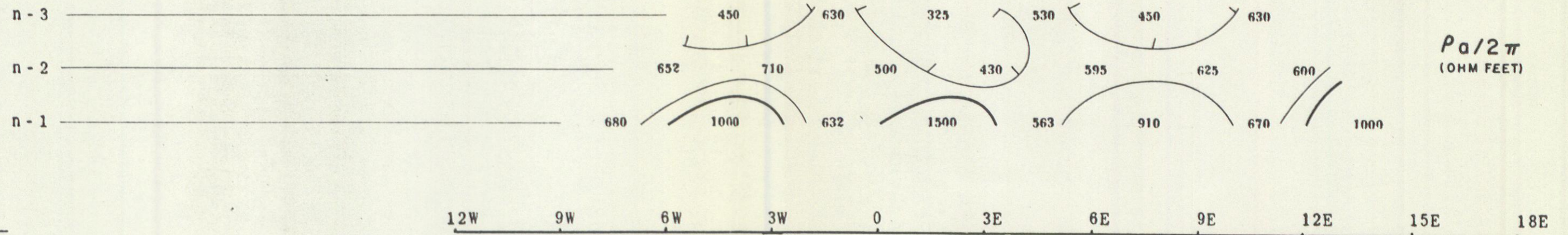
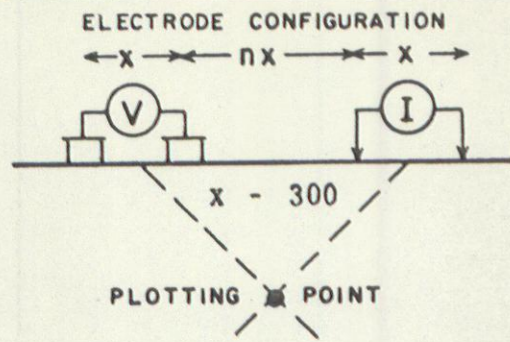

YUKON ANTIMONY CORPORATION LTD. (N.P.L.)

SKUKUM CREEK PROPERTY, YUKON TERRITORY.

(PHIL CLAIMS)

Scale - One inch = 300 Feet

NOTE: LOGARITHMIC CONTOUR INTERVAL

SURFACE PROJECTION OF ANOMALOUS ZONES

- DEFINITE
- PROBABLE
- POSSIBLE

FREQUENCY 0.3 - 5.0 CPS

DATE SURVEYED JULY 1967

APPROVED

DATE 7/18/67

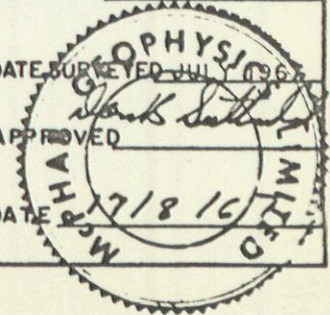

LINE NO.-40N

McPHAR GEOPHYSICS LIMITED

INDUCED POLARIZATION AND RESISTIVITY SURVEY

NOTE: CONTOURS AT LOGARITHMIC MULTIPLES OF 10-15-20-30-50-75-100

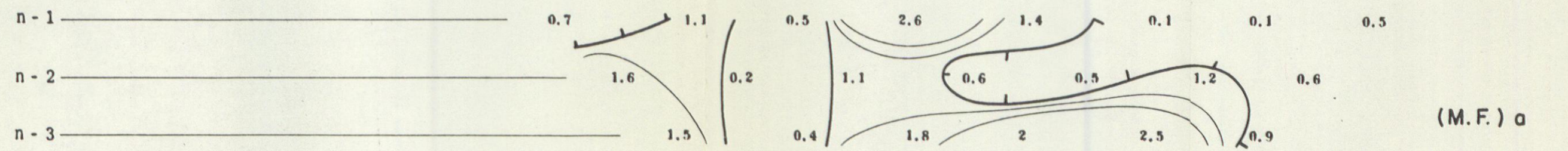
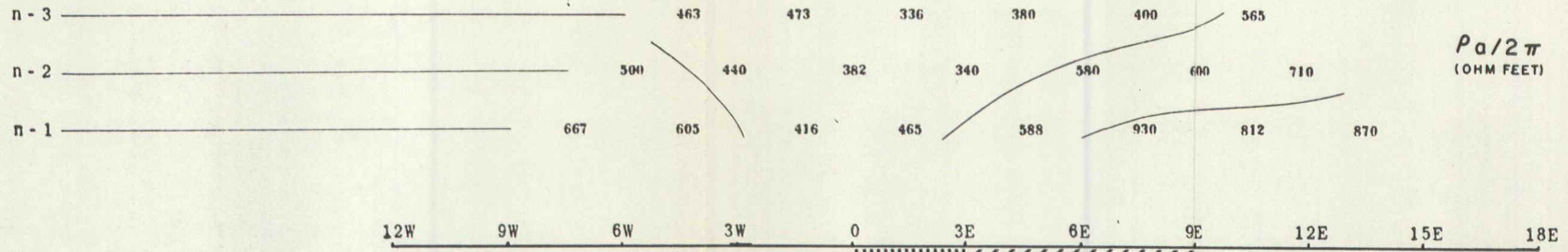
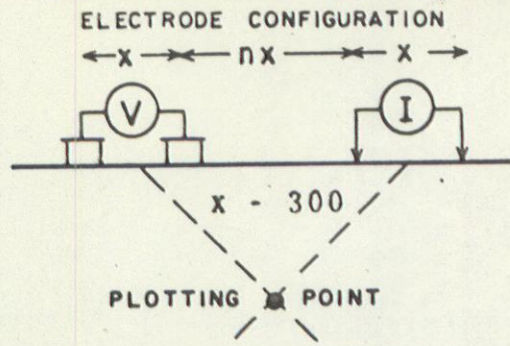

YUKON ANTIMONY CORPORATION LTD. (N.P.L.)

SKUKUM CREEK PROPERTY, YUKON TERRITORY.

(PHIL CLAIMS)

Scale - One inch = 300 Feet

NOTE: LOGARITHMIC CONTOUR INTERVAL

SURFACE PROJECTION OF ANOMALOUS ZONES

- DEFINITE
- PROBABLE
- POSSIBLE

FREQUENCY 0.3-5.0 CPS

DATE SURVEYED JULY 1967

APPROVED

DATE 7/18/67

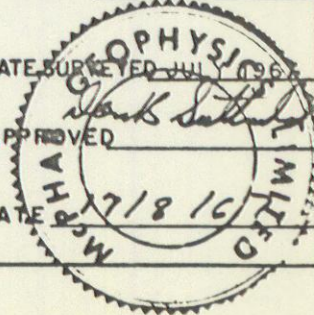

LINE NO.-45 N

McPHAR GEOPHYSICS LIMITED

INDUCED POLARIZATION AND RESISTIVITY SURVEY

NOTE: CONTOURS AT LOGARITHMIC MULTIPLES OF 10-15-20-30-50-75-100

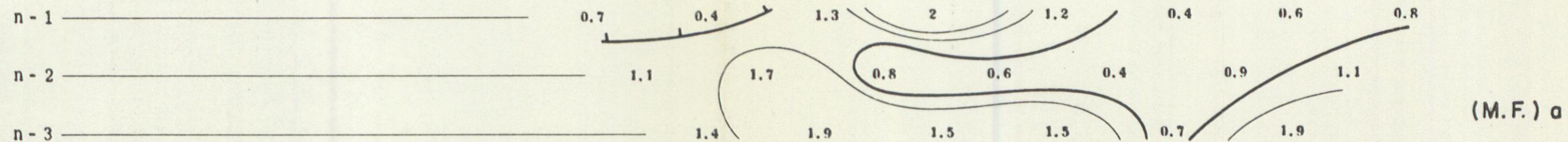
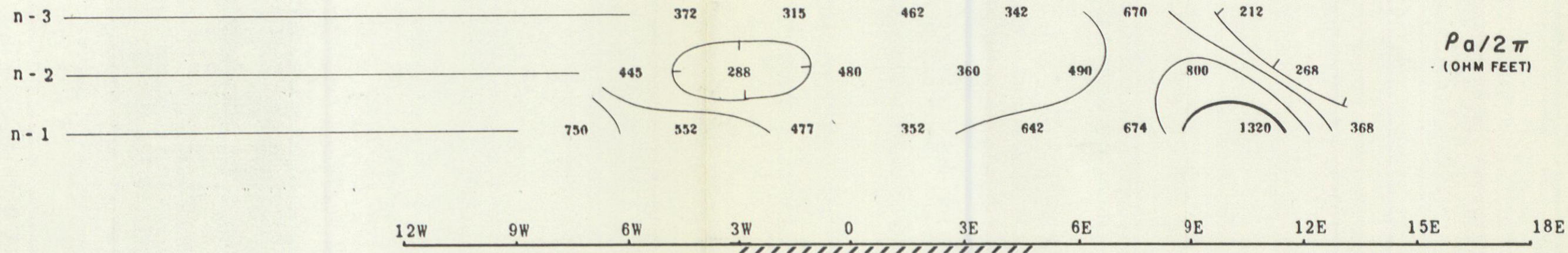
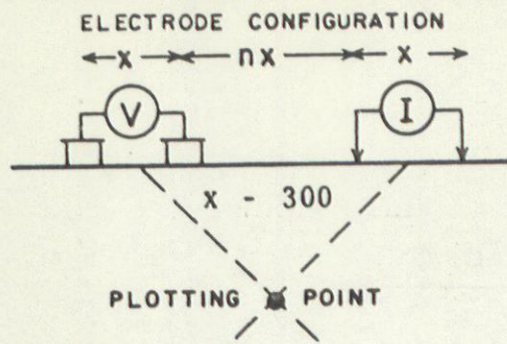

YUKON ANTIMONY CORPORATION LTD. (N.P.L.)

SKUKUM CREEK PROPERTY, YUKON TERRITORY.

(PHIL CLAIMS)

Scale - One inch = 300 Feet

NOTE: LOGARITHMIC CONTOUR INTERVAL

SURFACE PROJECTION OF ANOMALOUS ZONES

DEFINITE **—————**

PROBABLE **.....**

POSSIBLE **///////**

FREQUENCY 0.3 - 5.0 CPS

DATE SURVEYED JULY 1966

APPROVED

DATE 7/8/66

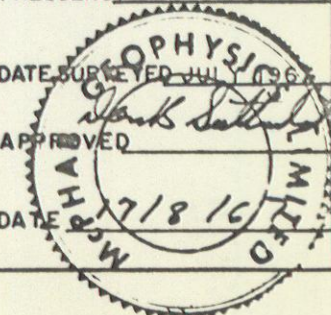

LINE NO.-50N

McPHAR GEOPHYSICS LIMITED

INDUCED POLARIZATION AND RESISTIVITY SURVEY

NOTE: CONTOURS AT LOGARITHMIC MULTIPLES OF 10-15-20-30-50-75-100

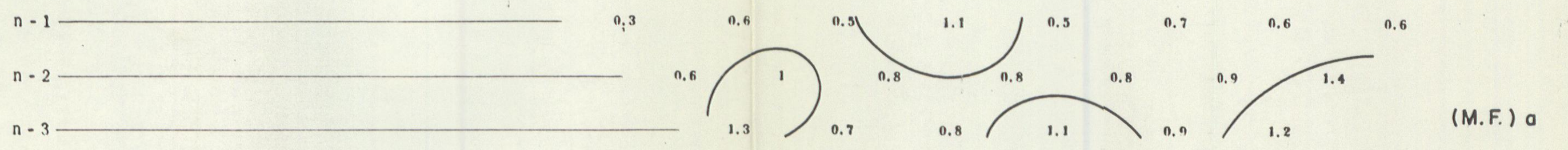
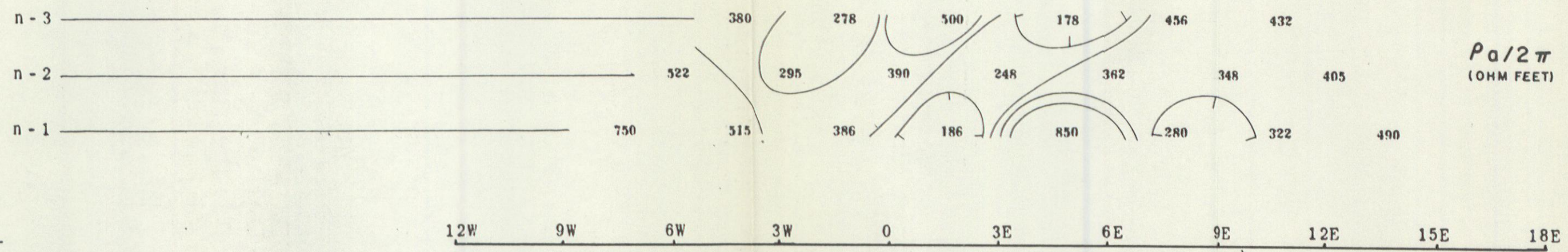
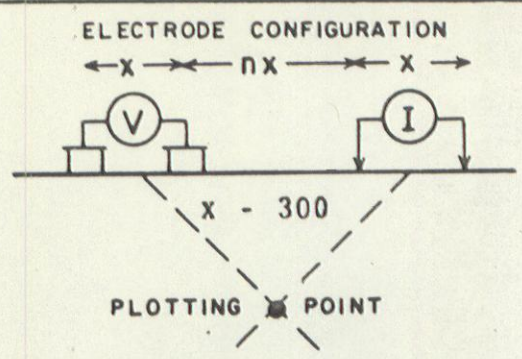

YUKON ANTIMONY CORPORATION LTD. (N.P.L.)

SKUKUM CREEK PROPERTY, YUKON TERRITORY.
(PHIL CLAIMS)

Scale - One inch = 300 Feet

NOTE: LOGARITHMIC CONTOUR INTERVAL

SURFACE PROJECTION OF ANOMALOUS ZONES
DEFINITE
PROBABLE
POSSIBLE

FREQUENCY 0.3-5.0 CPS

DATE SURVEYED JULY 1964
APPROVED
DATE 7/18/64

LINE NO.-55N

McPHAR GEOPHYSICS LIMITED

INDUCED POLARIZATION AND RESISTIVITY SURVEY

NOTE: CONTOURS AT LOGARITHMIC MULTIPLES OF 10-15-20-30-50-75-100

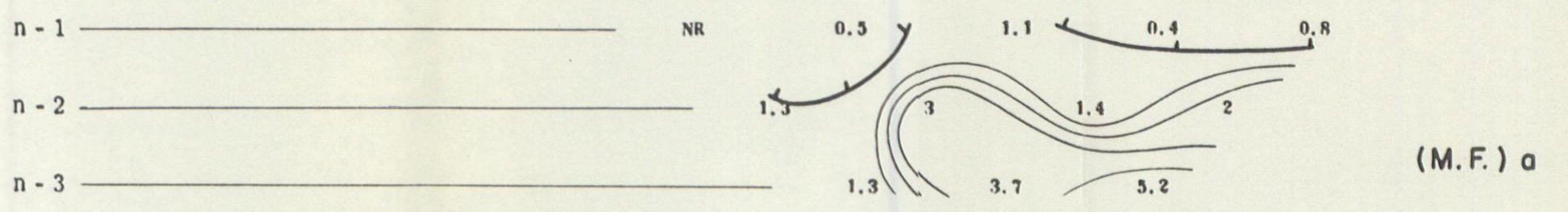
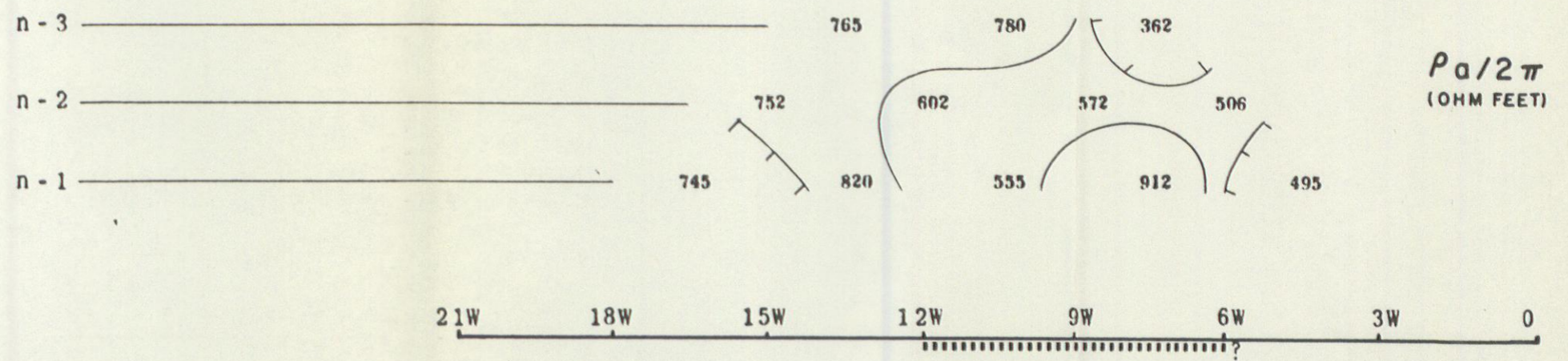
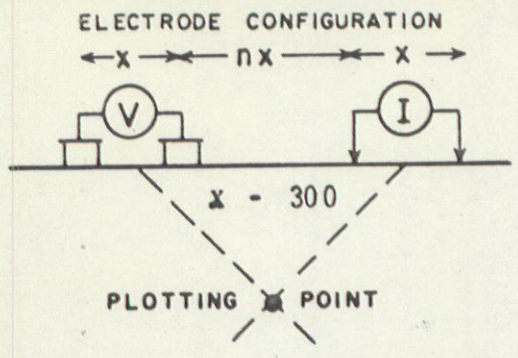

YUKON ANTIMONY CORPORATION LTD. (N.P.L.)

SKUKUM CREEK PROPERTY, YUKON TERRITORY.

(JOY CLAIMS)

Scale - One inch = 300 Feet

NOTE: LOGARITHMIC CONTOUR INTERVAL

SURFACE PROJECTION OF ANOMALOUS ZONES

DEFINITE

PROBABLE

POSSIBLE

FREQUENCY 0.3-5.0 CPS

DATE SURVEYED JULY 1967

APPROVED *Frank Sattler*

DATE 7/18/67

LINE NO.-EXT.-0

McPHAR GEOPHYSICS LIMITED

INDUCED POLARIZATION AND RESISTIVITY SURVEY

NOTE: CONTOURS AT LOGARITHMIC MULTIPLES OF 10-15-20-30-50-75-100

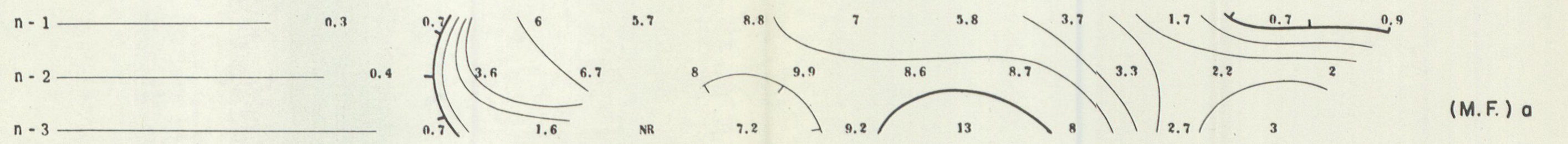
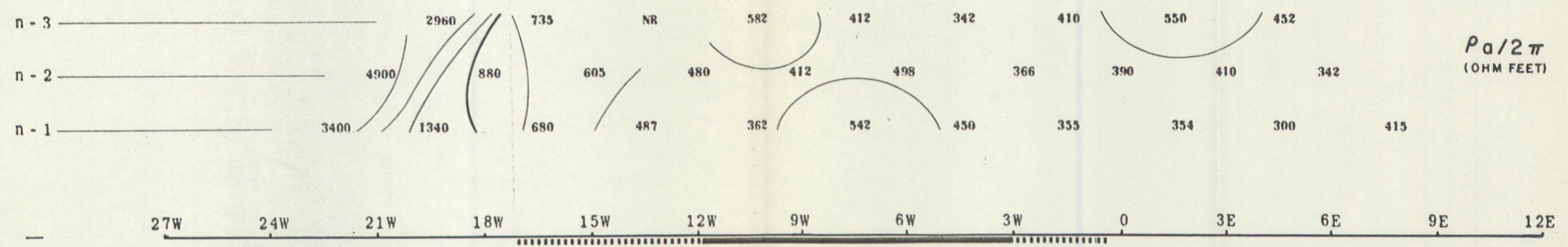
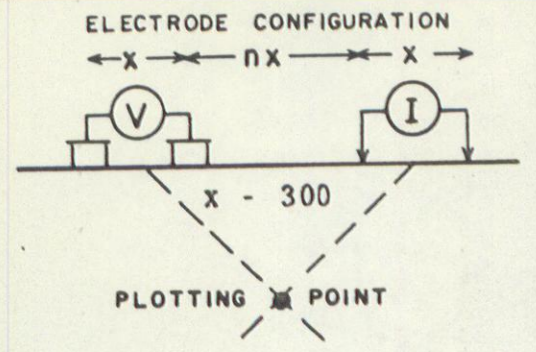

YUKON ANTIMONY CORPORATION LTD. (N.P.L.)

SKUKUM CREEK PROPERTY, YUKON TERRITORY.

(JOY CLAIMS)

Scale - One inch = 300 Feet

NOTE: LOGARITHMIC CONTOUR INTERVAL

SURFACE PROJECTION OF ANOMALOUS ZONES

- DEFINITE
- PROBABLE
- POSSIBLE

FREQUENCY 0.3-5.0 CPS

DATE SURVEYED JULY 1967

APPROVED

DATE 7/18/67

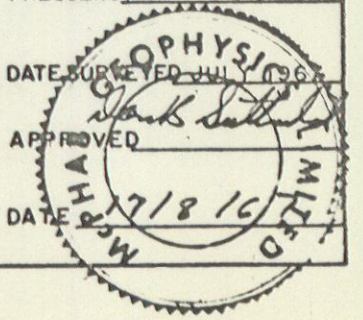

LINE NO. - EXT. - 55

McPHAR GEOPHYSICS LIMITED

INDUCED POLARIZATION AND RESISTIVITY SURVEY

NOTE: CONTOURS AT LOGARITHMIC MULTIPLES OF 10-15-20-30-50-75-100

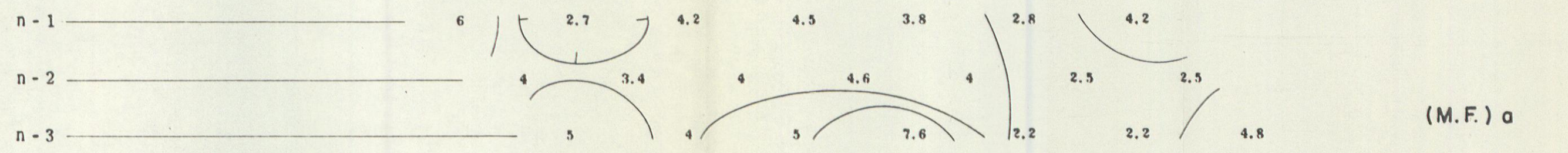
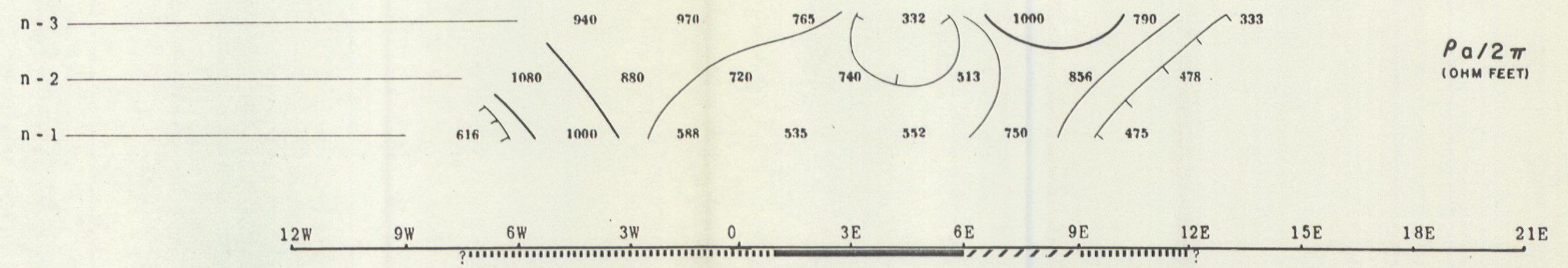
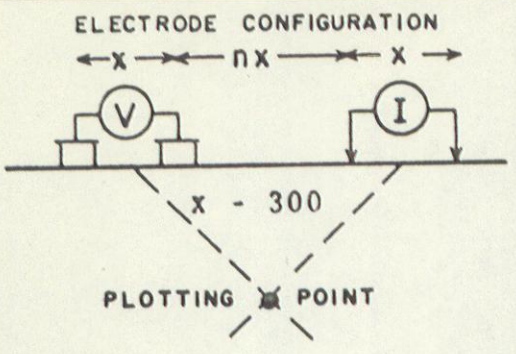

YUKON ANTIMONY CORPORATION LTD. (N.P.L.)

SKUKUM CREEK PROPERTY, YUKON TERRITORY.

(JOY CLAIMS)

Scale - One inch = 300 Feet

NOTE: LOGARITHMIC CONTOUR INTERVAL

SURFACE PROJECTION OF ANOMALOUS ZONES
DEFINITE
PROBABLE
POSSIBLE

FREQUENCY 0.3 - 5.0 C.P.S.

DATE SURVEYED JULY 1967

APPROVED

DATE 7/18/67

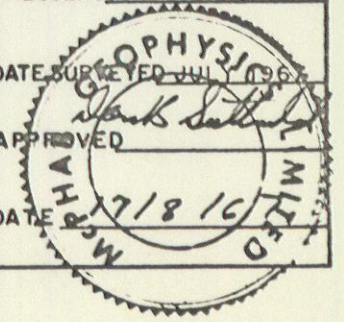

LINE NO.-EXT.-105

McPHAR GEOPHYSICS LIMITED

INDUCED POLARIZATION AND RESISTIVITY SURVEY

NOTE: CONTOURS AT LOGARITHMIC MULTIPLES OF 10-15-20-30-50-75-100

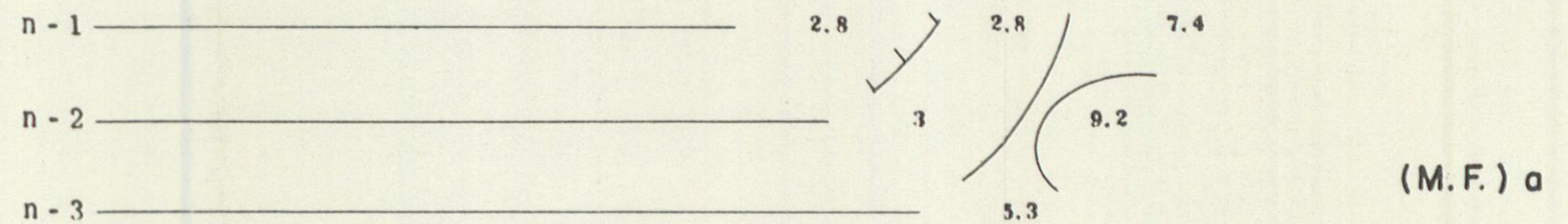
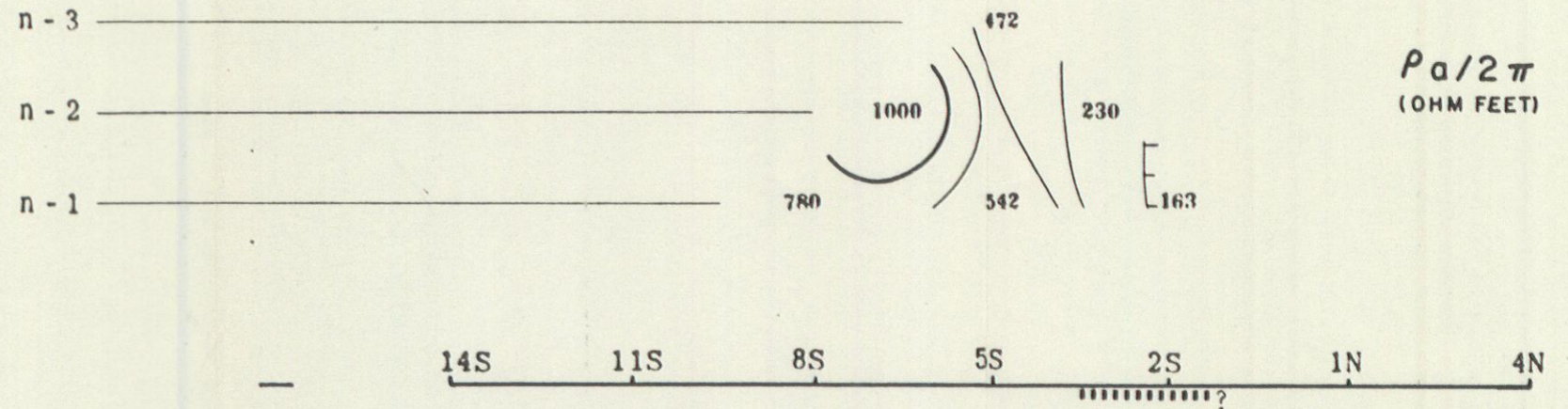
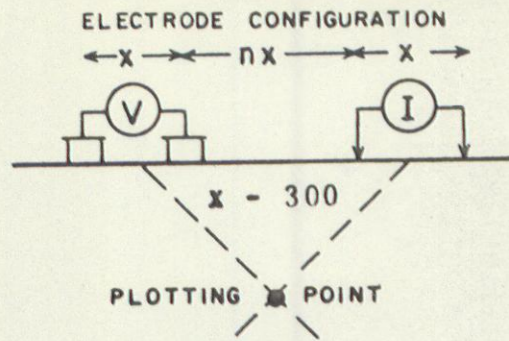

YUKON ANTIMONY CORPORATION LTD. (N.P.L.)

SKUKUM CREEK PROPERTY, YUKON TERRITORY.

(JOY CLAIMS)

Scale - One inch = 300 Feet

NOTE: LOGARITHMIC CONTOUR INTERVAL

SURFACE PROJECTION OF ANOMALOUS ZONES

- DEFINITE
- PROBABLE
- POSSIBLE

FREQUENCY 0.3-5.0 CPS

DATE SURVEYED JULY 1967

APPROVED

DATE 7/18/67

LINE NO.-BASELINE (N-S)